

Electronic-Key-System

Manual

EKS *Light* and *Light FSA*

Order No. 110 845



EKS. *Light*



More than safety.



EUCHNER

Table of contents

1	General notes	4
1.1	Use of the manual	4
1.1.1	Explanation of symbols	4
1.1.2	Abbreviations	5
1.2	CE conformity	5
1.3	Approvals	5
1.4	Correct use	6
1.5	Obligation on the operating organization	7
2	Safety precautions	8
3	Function	9
3.1	Functional Description	9
3.1.1	Functions of EKS <i>Light</i>	9
3.1.2	Additional functions of the version EKS <i>FSA</i>	11
4	Operating states	12
4.1	Function of the DIP switches	13
4.2	What operating states are available?	14
4.3	Operating state 0	15
4.3.1	Description of operating state 0	16
4.3.2	DIP switch settings in operating state 0	16
4.3.3	Operating state (OS) (bit nos. 10 to 13)	16
4.3.4	Access code (AC) (bit nos. 0 to 9)	16
4.3.5	Data on the Electronic-Key in operating state 0	17
4.3.6	User access in operating state 0	17
4.4	Operating state 1	18
4.4.1	Description of operating state 1	19
4.4.2	DIP switch settings in operating state 1	20
4.4.3	Operating state (OS) (bit nos. 10 to 13)	20
4.4.4	Access code (AC) (bit nos. 0 to 9)	20
4.4.5	Data on the Electronic-Key in operating state 1	20
4.4.6	User access in operating state 1	21
5	Technical data	22
5.1	Dimension drawing of Electronic-Key adapter compact	22
5.1.1	Version EKS-A-IP	22
5.1.2	Version EKS-A-IP... <i>FSA</i>	22

5.2	Dimension drawing of FHM Electronic-Key adapter modular.....	23
5.3	Dimension drawing of interface adapter modular	23
5.4	Technical data.....	24
5.5	Connector assignment for compact version	25
5.5.1	Plug-in screw terminals of the interface (4-bit parallel plus strobe).....	25
5.5.2	Plug-in screw terminals for power supply	25
5.5.3	Plug-in screw terminals for power supply and switching contact LA (only FSA version)	25
5.6	Connector assignment for interface adapter modular	26
5.6.1	Connection to FHM Electronic-Key adapter	26
5.6.2	Power supply, interface (4-bit parallel plus strobe) and switching contact LA (<i>FSA</i> version only)	26
5.7	LED indicator	27
6	Mounting.....	28
6.1	– Electronic-Key adapter compact.....	28
6.2	Electronic-Key adapter FHM.....	28
7	Electrical connection	29
7.1	Interface	30
7.2	Connection of power supply	30
7.3	Connection of semiconductor switching contact LA1/LA2 (only for EKS <i>FSA</i>)	31
7.3.1	Connection example with enabling switch	32
7.3.2	Connection example without enabling switch	35
8	Parameter assignment of the Electronic-Keys via the Electronic-Key-Manager EKM software.....	38
9	Setup.....	39
10	Exclusion of liability	39
11	Service and repair	39
12	Guarantee.....	39

1 General notes

1.1 Use of the manual

This manual describes the technical features and the function of the EKS *Light* read stations listed below:

With the compact version, the Electronic-Key adapter and the evaluation and interface electronics for data transmission are accommodated completely in one housing.

- ▶ Compact Electronic-Key adapter EKS-A-IPB-G01-ST05/02 (order no. 111 230); device supports only operating state 0
- ▶ Compact Electronic-Key adapter EKS-A-IPL-G01-ST05/02 (order no. 109 820); device supports all operating states
- ▶ Compact Electronic-Key adapter EKS-A-IPLA-G01-ST05/04 (order no. 112 207); device supports all operating states; version *FSA* (For **S**afety **A**pplications)

With the modular version, the Electronic-Key adapter and the interface adapter with the evaluation and interface electronics for data transmission are accommodated in two separate housings:

- ▶ Modular Electronic-Key adapter EKS-A-SFH... in combination with modular interface adapter EKS-A-APB-G08 (order no. 113 665); device supports only operating state 0
- ▶ Modular Electronic-Key adapter EKS-A-SFH... in combination with modular interface adapter EKS-A-APR-G08 (order no. 113 647); device supports all operating states
- ▶ Modular Electronic-Key adapter EKS-A-SFH... in combination with modular interface adapter EKS-A-APRA-G08 (order no. 113 645); device supports all operating states; version *FSA* (For **S**afety **A**pplications)

1.1.1 Explanation of symbols

The following symbols are used in this manual to identify important instructions and useful information.

**Danger!**

Identifies an immediate hazard. If not avoided, the consequence will be fatality or very serious injuries.

**Warning!**

Identifies a possible hazard. If not avoided, the consequence may be fatality or very serious injuries.

**Caution!**

Identifies a possible hazard. If not avoided, minor injuries or damage may result.

**Attention!**

Risk of damage to material or machine or degradation of function.

**Information!**

Important information is provided to the user here.

1.1.2 Abbreviations

The following abbreviations are used in this manual:

▶ AC	A ccess C ode
▶ AL	A ccess L evel
▶ CRC	C yclic R edundancy C heck
▶ DIP	D ual I ndline P ackage
▶ EKM	E lectronic- K ey- M anager
▶ EKS	E lectronic- K ey- S ystem
▶ FHM	F ront H ook M odular
▶ FSA	F or S afety A pplications
▶ LED	L ight E mitting D iode
▶ LSB	L east S ignificant B it
▶ MSB	M ost S ignificant B it
▶ OS	O perating S tate
▶ PA	P olyamide
▶ PVDF	P olyvinylidenfluoride

1.2 CE conformity

The EKS *Light* read stations conform to the **EMC directive** 2004/108/EC (2004/108/EC, 2004/108/CE).

The read stations comply with the following European/international standards:

EN 61000-6-2: 2005	Electromagnetic compatibility (EMC) - Generic standards - Immunity for industrial environments
EN 55011:2007 + A2:2007 (ISM)	Industrial, scientific and medical (ISM) radio-frequency equipment - Radio disturbance characteristics - Limits and methods of measurement

1.3 Approvals

The EKS *Light* read stations are certified in accordance with  (UL File Number E240367).

For use and operation as per the  requirements, a power supply **for use in class 2 circuits** must be used.

1.4 Correct use

As part of a higher-level overall system, the EKS read station is used for access control and monitoring on control systems or parts of control systems (e.g. of machines). The EKS can be used, for example, as part of an overall system for checking access rights for operating mode selection. However, it is not permitted to directly derive the operating mode from the access rights on the Electronic-Key. If the selection of the operating mode is relevant for safety, this must not be performed by means of the EKS; instead an additional device must be used to select the operating mode. This is possible via the graphical user interface on the control system, for example.

Outputs A, B, C, D and strobe plus the switching contact LA1/LA2 switch only if there is an authorized Electronic-Key in the read station. Outputs A, B, C, D and strobe (channel LB) plus the switching contact LA1/LA2 (channel LA) must be polled by a safe downstream evaluation to suit the risk determined. The outputs A, B, C, D and strobe (channel LB) are used to supply the information as to whether the or not an Electronic-Key is inserted and which access rights are assigned to the Electronic-Key. The output LA1/LA2 (channel LA) is used for the redundant supply of the information as to whether or not an authorized Electronic-Key is inserted (independent of the access rights).

- ▶ The control system must check whether the Electronic-Key placed is authorized to select the operating mode and whether the access rights on the Electronic-Key permit operation in the operating mode currently selected.
- ▶ The user must select the related operating mode using the control system or another suitable circuit.
- ▶ The manufacturer of the system must check which safety level is reached with the overall system and whether the overall system provides adequate safety against hazards in the intended application.

Information!



The machinery directive 2006/42/EC provides information on selection of the operating mode. It is imperative that this information be followed.

When designing machines and using the read station, the national and international regulations and standards specific to the application must be observed, e.g.:

- ▶ EN 60204, Safety of machinery - Electrical equipment of machines
- ▶ EN 12100-1, Safety of machinery - Basic concepts, general principles for design - part 1: basic terminology, methodology
- ▶ EN 62061, Safety of machinery – Functional safety of safety-related electrical, electronic and programmable electronic control systems
- ▶ EN ISO 13849-1, Safety of machinery. Safety related parts of control systems - part 1: General principles for design

Modifications to the electronics of the read station and any other changes, especially mechanical modifications and reworking, are not permissible and will result in the loss of the warranty and exclusion of liability.

The read station must only be employed and used in accordance with

- ▶ this manual and
- ▶ other documentation referred to in this manual.

The EKS read station is not a safety component in the sense of the machinery directive.

Without additional precautions the EKS read station must not be used to provide a safety function, particularly if failure or malfunction of the unit could endanger the safety or health of people in the operating area of a machine.

For applications in which the machinery directive is not applicable (vehicle manufacturing, building services engineering or similar), the applicable regulations and standards from the respective field must be taken into account.

1.5 Obligation on the operating organization

The manufacturer of and the organization operating the higher-level overall system, e.g. a machine installation, are responsible for the observance of national and international safety and accident prevention regulations applicable in the specific case.

2 Safety precautions

**Warning!**

The EKS read station is not a safety component in the sense of the machinery directive. Without additional precautions the EKS read station must not be used to provide a safety function, particularly if failure or malfunction of the unit could endanger the safety or health of persons in the operating area of a machine. On this topic pay particular attention to the sections *Correct use* (see section 1.4) and *Electrical connection* (see section 7).

**Warning!**

Mounting and electrical connection are only allowed to be performed by authorized personnel who are familiar with the applicable regulations on accident prevention and have read and understood this manual.

**Caution!**

Modifications to the electronics of the read station and any other changes, especially mechanical modifications and reworking, are not permissible and will result in the loss of the warranty.

3 Function

3.1 Functional Description

3.1.1 Functions of EKS *Light*

EKS *Light* is used on control systems or parts of control systems for access control and monitoring.

Instead of passwords, coded Electronic-Keys are assigned. In this way, unauthorized system access (e.g. to control and visualization systems) is prevented to the greatest possible extent.

EKS *Light* uses a non-contact, inductive read identification system.

It consists at least of:

- ▶ Electronic-Key
- ▶ Electronic-Key adapter EKS *Light* compact or Electronic-Key adapter FHM with interface adapter EKS *Light* modular

For configuration, you will require at least the following items:

- ▶ A commercially available Windows® PC
- ▶ EKS Electronic-Key adapter with USB interface or serial interface
- ▶ Electronic-Key-Manager EKM *Light* software

Programming of the application and the integration into an overall system are organized by the user.

EKS *Light* is characterized by simple integration into the control system environment. After the Electronic-Key is placed, the Electronic-Key's data are evaluated within the device as the first step, which permits automatic Electronic-Key recognition without the aid of the control system. Once the internal check of the data integrity is complete, an access level is issued at the data outputs.

The EKS *Light* read station is a read-only system with integrated evaluation electronics and interface. The access level is output via a 4-bit parallel interface. The parallel interface offers the advantage of transparent depiction of the data and therefore simple connection directly to the inputs of a control system or a switching device.

An EKS operating state (OS), an access level (AL), an access code (AC), a checksum (CRC) and a serial number are stored on the Electronic-Key. When an Electronic-Key is inserted, the data range relevant for the respective operating state is automatically read from the Electronic-Key into the device, temporarily stored there and evaluated. If a valid Electronic-Key is detected, the outputs on the read station are set to High depending on the stored values of the access level. All outputs are reset to Low when the Electronic-Key is withdrawn.

The read station and Electronic-Key are separately parameterized with values which have to match. Parameter assignment to the Electronic-Key adapter is performed exclusively via the DIP switch.

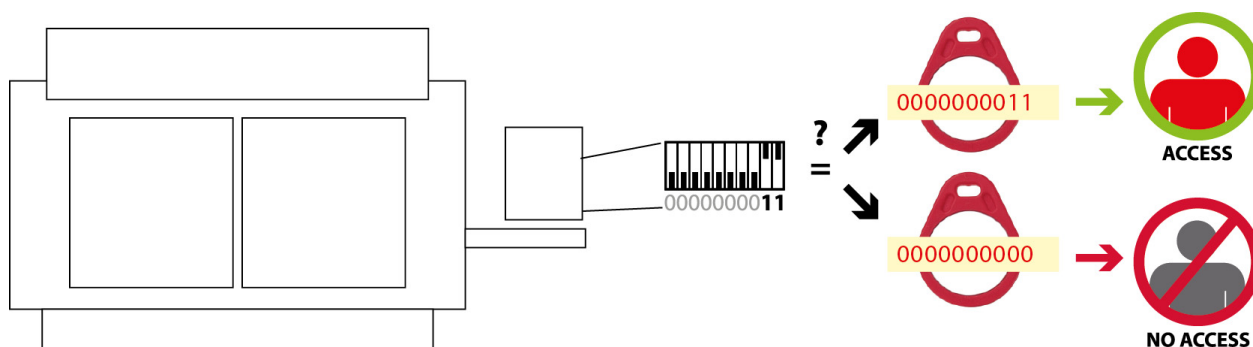

Figure 1: DIP switch setting and access code on the Electronic-Key.

Parameter assignment for the Electronic-Keys is performed exclusively via a programming station on the PC. An EKS Electronic-Key adapter with USB interface (order No. 092 750) or with serial interface (order No. 084 750) is installed on the PC for this purpose. Programming is performed via the Electronic-Key-Manager EKM software with an input mask suitable for the operating state (see section 8 Parameter assignment of the Electronic-Keys via the Electronic-Key-Manager EKM software)

Due to the non-contact transfer of data, the Electronic-Key adapter is designed with a high degree of protection suitable for industry from the access side. The Electronic-Key adapter is fastened from the rear side of the panel in order to exclude unauthorized tampering from the operator side.

The current state of the Electronic-Key adapter is displayed using a 3-color LED.

The Electronic-Keys are tag shaped. The complete transponder with memory chip and antenna is integrated into the Electronic-Key. The transponder does not have a battery.

The Electronic-Key is placed on the Electronic-Key adapter for operation. The power supply for the transponder and the data are transferred contactlessly between the Electronic-Key adapter and Electronic-Key.

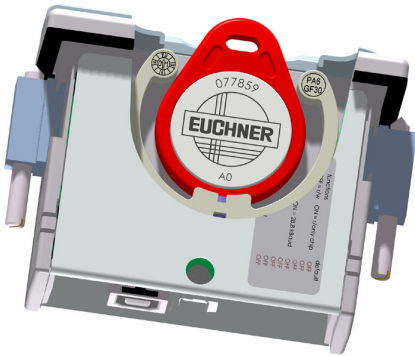

Figure 2: Cut-away illustration of an Electronic-Key adapter with Electronic-Key in the compact version

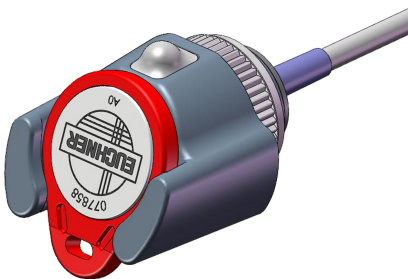

Figure 3: Illustration of an Electronic-Key adapter with Electronic-Key in the modular version

3.1.2 Additional functions of the version EKS *FSA*

The EKS *FSA* version features an additional semiconductor switching contact (LA1/LA2) that is switched off as long as there is no authorized Electronic-Key in the Electronic-Key adapter or if the Electronic-Key cannot be read.

The semiconductor switching contact is galvanically isolated from the device electronics. Either AC or DC can be switched. Outputs A, B, C, D and strobe on the first channel LB and the semiconductor switching contact on the second channel LA are each operated with diversity by a dedicated processor that switches off the outputs or the switching contact on removal of the Electronic-Key (see Figure Block diagram EKS *FSA*).

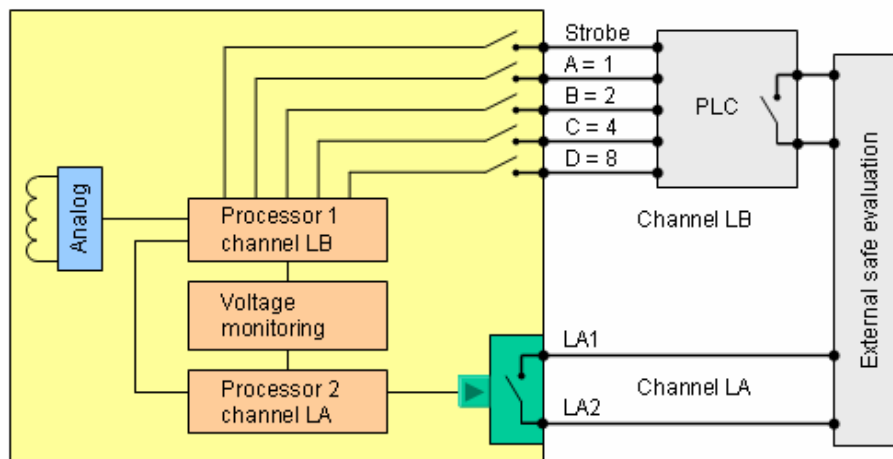

Figure 4: Block diagram EKS *FSA*

By separately evaluating channel LB and channel LA, the EKS *FSA* device can be used in conjunction with a safe evaluation device in safety-related applications. Integrated voltage monitoring switches off outputs A, B, C, D and strobe (channel LB) or the semiconductor switching contact (channel LA) if the power supply is outside the permitted tolerance (see section 5.2).

4 Operating states

Information!

- o Various operating states are available, depending on the EKS *Light* version.
- o Refer to section 1.1 Use of the manual to check which operating state your device supports.

The operating state determines the function of the system, which comprises the read station (also referred to as device below) and Electronic-Key. The operating state defines the scheme according to which automatic Electronic-Key recognition functions and how an access level is issued.

The operating state is set using DIP switches on the read station. The various operating states are stored in the device software (firmware). The value for the operating state is also programmed on the Electronic-Key. Values in the Electronic-Key and in the device must match.

What is the same in all operating states?

- ▶ Parity bit comparison in the device. The parity bit is used to check the values set within the DIP switch. By this an accidentally reset or faulty DIP switch can be recognized.
- ▶ Matching of the EKS *Light* data block on the Electronic-Key with the set values in the device. This also includes a comparison of the checksum (CRC). The checksum is stored on the Electronic-Key. After the Electronic-Key is inserted, the checksum is calculated in the device and compared with the value on the Electronic-Key. Access is released only if the values agree. The checksum is formed using the programmed EKS *Light* data block required for the operating state and the serial number of the Electronic-Key. Like the serial number, the checksum is therefore also a unique number. The cyclic redundancy check routine prevents data manipulation outside of the defined software environment.

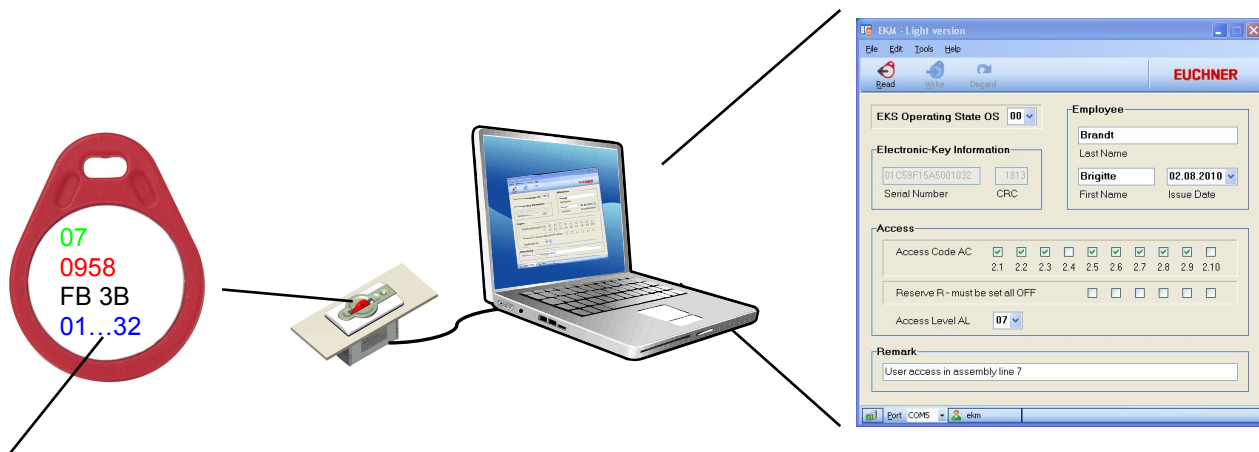

Electronic-Key memory structure

Byte no.:	0	115	116	...	123
Function:	freely available		Operating State, Access Level, Access Code		EKM CRC (dynamically generated by EKM software)		Serial number (cannot be changed)	
	-		EKS <i>Light</i> data block				Blocked data	

Some parameters and functions vary from one operating state to the next, e.g.:

- ▶ The EKS *Light* data block may have a different length, depending on the operating state.
- ▶ Therefore, the start byte in the programmable memory area of the Electronic-Key can be in a different location, depending on the operating state.
- ▶ Different evaluation options of the DIP switch coding and the programming of the EKS *Light* data block on the Electronic-Key.

Furthermore, additional functions are available in the individual operating states. Please refer to the respective section.

4.1 Function of the DIP switches

The following settings can be made with the DIP switches:

- ▶ S1.1 (bit no. 15) even parity bit (even)

The number of switches set to ON from S1.2 to S2.10 is determined. If this value is an even number, then switch S1.1 is set to OFF (respectively it remains in the factory setting). If this value is an odd number, then switch S1.1 is set to ON.

- ▶ S1.2 (bit no. 14) no function

It is essential to set switch S1.2 to OFF!

- ▶ S1.3 to S1.6 (bit nos. 10 to 13) operating state

The operating state is set in binary form using switches S1.3 to S1.6. A decimal value from 0 to 15 can be set.

- ▶ S2.1 to S2.10 (bit nos. 0 to 9) access code

The access code is set using switches S2.1 to S2.10. The interpretation of the values set here differs depending on the operating state.

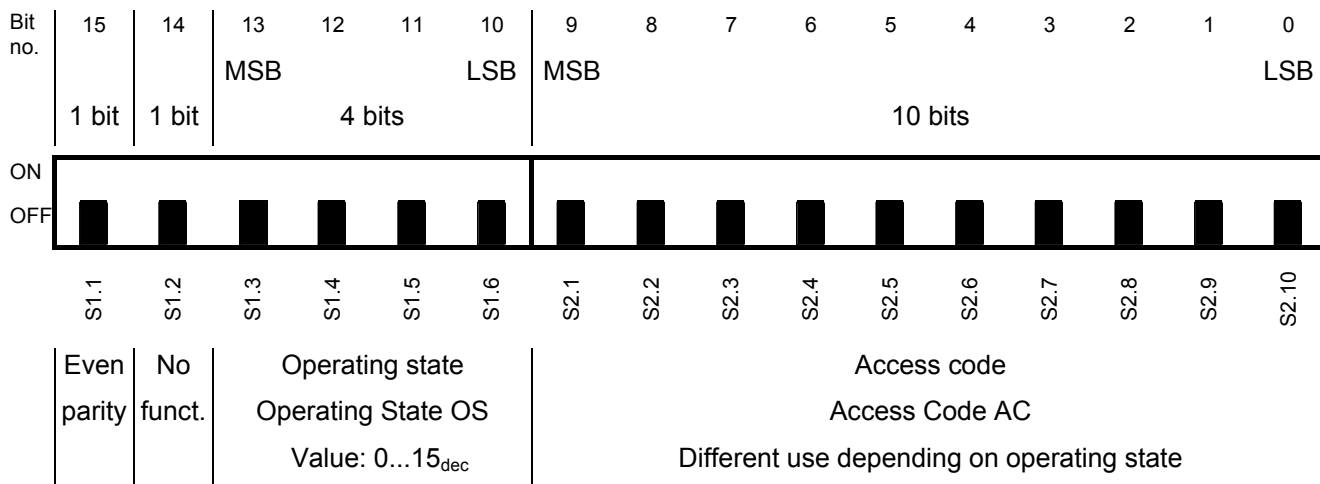

(factory setting: all switches in OFF position)

Information!



The settings are only applied when the power supply is switched on.

If all switches are set to OFF, the entire parameter assignment is reset to the factory setting.

4.2 What operating states are available?

Depending on the application, various operating states can be selected. The differences between the different operating states are explained briefly below. For more detailed information, please read the section for the respective operating state.

Operating state	Description
0	<p>General</p> <ul style="list-style-type: none"> ▶ Access is possible only to those installations for which exactly the same access code is set in the DIP switch and on the Electronic-Key (1:1 allocation) <p>Forming user groups</p> <ul style="list-style-type: none"> ▶ A separate Electronic-Key must exist for each user group. Users belonging to several groups therefore need several Electronic-Keys. <p>Forming installation groups</p> <ul style="list-style-type: none"> ▶ It is possible to form installation groups by setting the same access code on all installations of a group.
1	<p>General</p> <ul style="list-style-type: none"> ▶ The access code on the Electronic-Key can be structured so that several installations can be covered with different access codes (1:n allocation). In this case, the matching of one bit position of the bit pattern on the Electronic-Key and DIP switch is sufficient. <p>Forming user groups</p> <ul style="list-style-type: none"> ▶ The installations (installation groups) to which the user has access are defined on the user's Electronic-Key. ▶ A user can gain access to different installations (installation groups) with one Electronic-Key (e.g. service Electronic-Key for maintenance personnel). <p>Forming installation groups</p> <ul style="list-style-type: none"> ▶ It is possible to form installation groups by setting the same access code on all installations of a group.

4.3 Operating state 0

Application example:

Requirement:

- ▶ There are three lathes **D** in a factory. They are to be operated by **USER A** and **USER B**.
- ▶ **USER B** additionally is to be able to operate a milling machine **F**.

Solution with EKS *Light*:

- ▶ A certain access code is set for all lathes **D** with the DIP switch on the read station (here: the binary value 0000000001).
- ▶ The milling machine **F** is assigned the binary value 0000000011.
- ▶ **USER A** receives an Electronic-Key with the access code 0000000001 (for lathes **D**).
- ▶ **USER B** receives an Electronic-Key with the access code 0000000001 (for lathes **D**) and a second Electronic-Key with the access code 0000000011 (for the milling machine **F**).
- ▶ In addition to the access code, each user is assigned an access level with a value from 0 to 15.

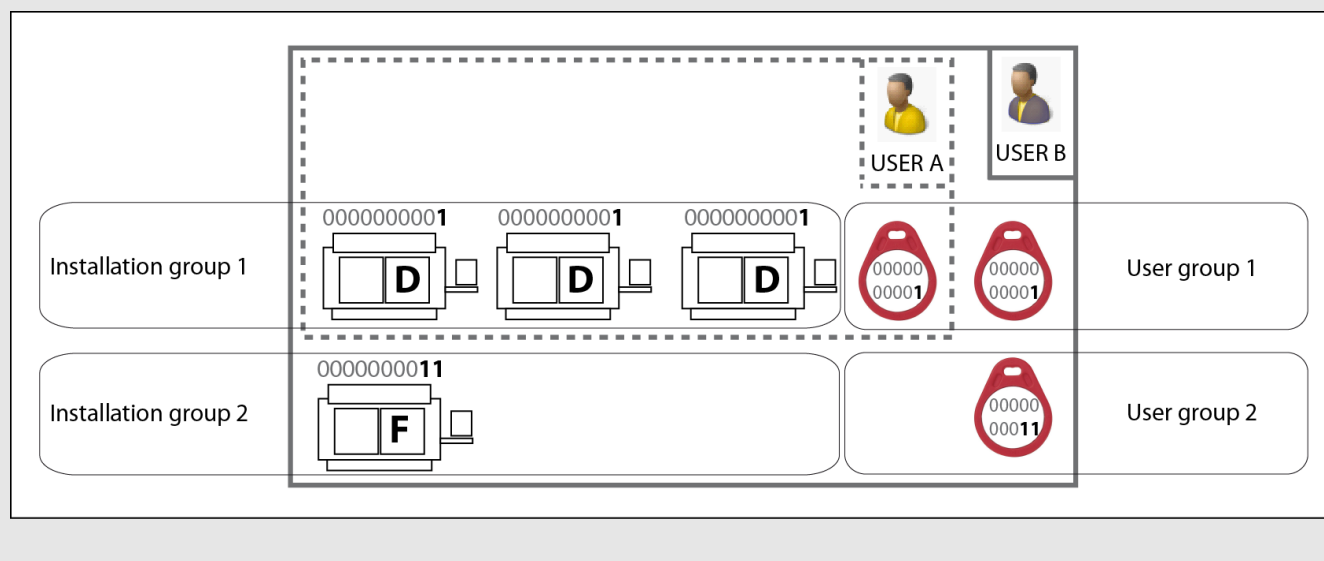

4.3.1 Description of operating state 0

An operating state (OS), an access level (AL) and an access code (AC) are stored on the Electronic-Key (see section 8 Parameter assignment of the Electronic-Keys via the Electronic-Key-Manager EKM software). If an authorized user is recognized via a valid Electronic-Key, the outputs on the read station (also referred to as device below) are set to High in accordance with the stored access level values. All values on the Electronic-Key must lie within the possible value range. All outputs are reset to Low when the Electronic-Key is withdrawn.

An Electronic-Key can access a suitably set read station via the access code. An unlimited number of Electronic-Keys can be programmed with the same access code (e.g. user group). An unlimited number of read stations can have the same access code set via the DIP switch (e.g. installation group).

The access code is 10 bits long. These 10 bits are available on the DIP switch for setting and in the Electronic-Key for programming (binary coding). The access code results from the setting of individual bits (bit setting = value 1) on the DIP switch in the device and the setting of individual bits in the access code on the Electronic-Key. Unique values from 0 to 1023 are possible for the access code. In operating state 0, only an exact match of the bit pattern between the Electronic-Key and device will lead to access.

If access is released via the access code, the strobe signal will be set and the access level will be statically issued with one of 16 possible levels via the 4-bit data wire as long as the Electronic-Key remains inserted.

The derivation of access rights to machine functions according to the output of the access level is carried out through the control at the user's location.

4.3.2 DIP switch settings in operating state 0

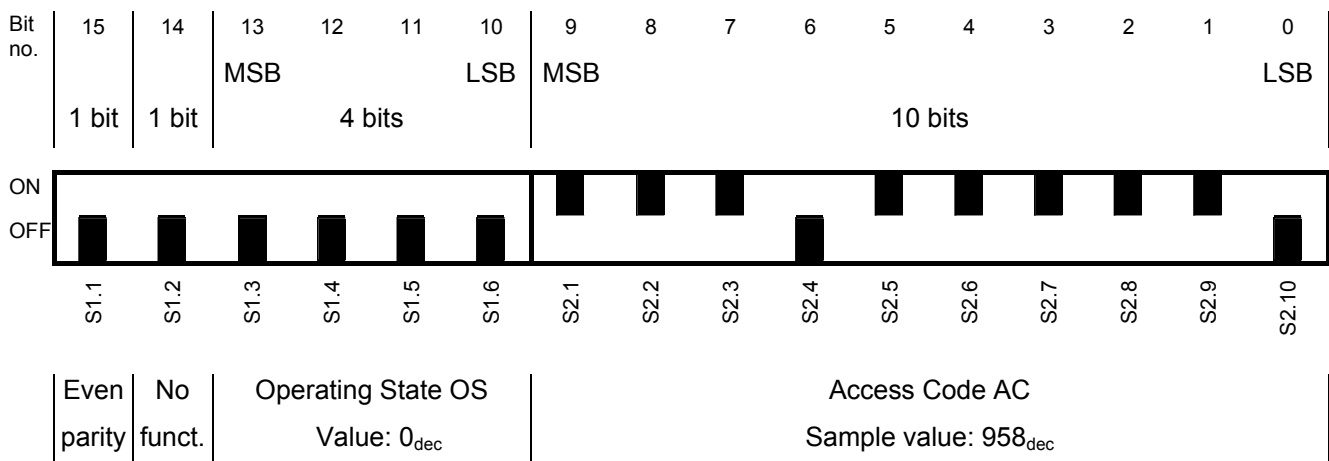

4.3.3 Operating state (OS) (bit nos. 10 to 13)

The operating state is set in binary form using switches S1.3 to S1.6. The value is always 0 for operating state 0; all switches S1.3 to S1.6 are therefore set to OFF. Operating state 0 is the factory setting.

4.3.4 Access code (AC) (bit nos. 0 to 9)

The access code is set in binary form using switches S2.1 to S2.10. An access code therefore results from the bit pattern of the set bits. Values from 0 to 1023 (10 bits) are possible.

4.3.5 Data on the Electronic-Key in operating state 0

In an EKS *Light* data block with a length of 6 bytes, the following elements are stored on the Electronic-Key from Electronic-Key byte no. 110:

- ▶ the EKS operating state (OS) with the value 0 (input via EKM)
- ▶ an access code (AC) with the value 0 to 1023 (input via EKM)
- ▶ an access level (AL) with the value 0 to 15 (input via EKM)
- ▶ a cyclic redundancy check (CRC) (automatically generated via EKM)
- ▶ a serial number (fix coded)

Block byte no.:															0	1
Key byte no.:	96	97	98	99	100	101	102	103	104	105	106	107	108	109	110	111
Value [dec]:																
Value [hex]:																
Function:	freely available for further EKS application														used...	
Block byte no.:	2	3	4	5												
Key byte no.:	112	113	114	115	116	117	118	119	120	121	122	123				
Value [dec]:																
Value [hex]:					01	1A	1E	F1	02	00	10	32				
Function:	...for operating state 0				Serial number (sample values)											

4.3.6 User access in operating state 0

Prerequisites for user access

1. Operating state 0 (value 0) is set on the device using DIP switch.
2. Access code (value 0 to 1023) is set on the device using DIP switch.
3. Parity bit check within the DIP switches in the device is conclusive.
4. Operating state 0 (value 0) is programmed on the Electronic-Key via EKM.
5. Access code (value 0 to 1023) is programmed on the Electronic-Key via EKM.
6. Access level (value 0 to 15) is programmed on the Electronic-Key via EKM.

Conditions for user access

1. Values for operating state in the device and on the Electronic-Key match.
2. Values for access code in the device and on the Electronic-Key match exactly.
3. Cyclic redundancy check is conclusive.

Issuance of user access

1. Strobe output is statically set to High level.
2. Access level (value 0 to 15) is statically set to 4-bit data output.

4.4 Operating state 1

Application example:

Requirement:

- ▶ There are two lathes **D** in a factory. They are to be operated by **USER A** and **USER B**.
- ▶ **USER B** additionally is to be able to operate a grinding machine **S**.
- ▶ There are also two milling machines **F**, which are both to be operated by **USER C** and **USER D**.
- ▶ The **service technician** is to have access to all machines.

Solution with EKS *Light*:

- ▶ A certain bit in the access code is set for the two lathes **D** using the DIP switch on the read station (here: bit 0). Position of the DIP switch: 0000000001.
- ▶ Bit 3 is set for the grinding machine **S**. Position of the DIP switch: 0000001000.
- ▶ Bit 4 is set for one of the two milling machines **F**, and bit 6 is set for the other one. Position of the DIP switches: Function of the DIP switches 0001000000 and 0000010000.
- ▶ **USER A** receives an Electronic-Key with the access code 0000000001 (for lathes **D**).
- ▶ **USER B** receives an Electronic-Key with the access code 0000001001 (for the lathes **D** and the grinding machine **S**).
- ▶ **USER C** and **USER D** receive an Electronic-Key with the access code 0001010000 (for the milling machines **F**). Bits 4 and 6 were set on every Electronic-Key here.
- ▶ The **service technician** receives an Electronic-Key on which all bits from 0 to 9 are set (access code 1111111111).
- ▶ In addition to the access code, each user is assigned an access level with a value from 0 to 15.

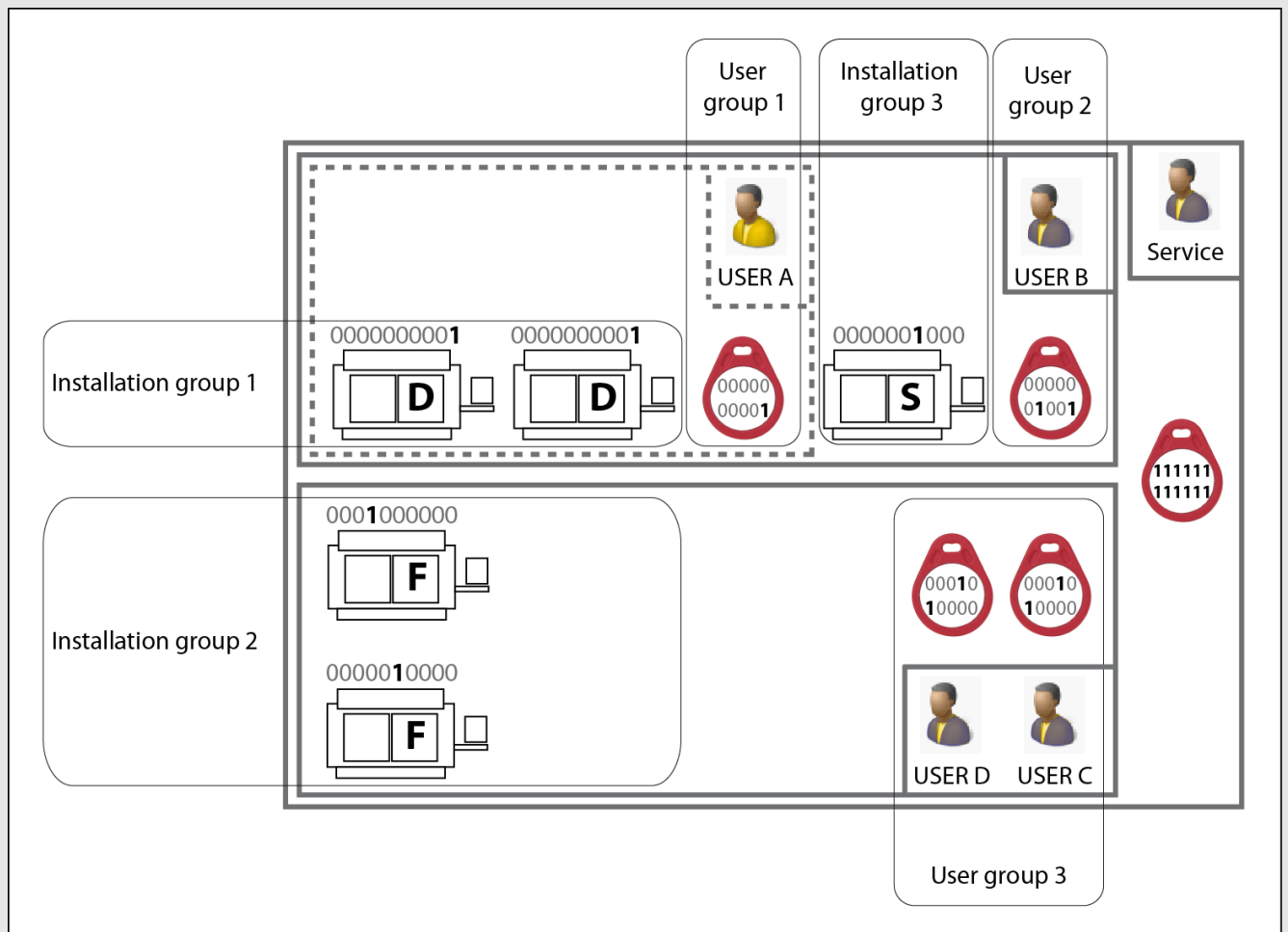

4.4.1 Description of operating state 1

An operating state (OS), an access level (AL) and an access code (AC) are stored on the Electronic-Key (see section 8 Parameter assignment of the Electronic-Keys via the Electronic-Key-Manager EKM software). If an authorized user is recognized via a valid Electronic-Key, the outputs on the read station (also referred to as device below) are set to High in accordance with the stored access level values. All values on the Electronic-Key must lie within the possible value range. All outputs are reset to Low when the Electronic-Key is withdrawn.

An Electronic-Key can access a suitably set read station via the access code. An unlimited number of Electronic-Keys can be programmed with the same access code (e.g. user group). An unlimited number of read stations can have the same access code set via the DIP switch (e.g. installation group).

The access code is 10 bits long. These 10 bits are available on the DIP switch for setting and in the Electronic-Key for programming (binary coding). The access code results from the setting of individual bits (bit setting = value 1) on the DIP switch in the device and the setting of individual bits in the access code on the Electronic-Key. All bits can be set independently of each other. Several bits can be set on the DIP switch and on the Electronic-Key. In operating state 1, a match of the bit pattern between the Electronic-Key and device at any bit position will lead to access.

If access is released via the access code, the strobe signal will be set and the access level will be statically issued with one of 16 possible levels via the 4-bit data wire as long as the Electronic-Key remains inserted.

The derivation of access rights to machine functions according to the output of the access level is carried out through the control at the user's location.

4.4.2 DIP switch settings in operating state 1

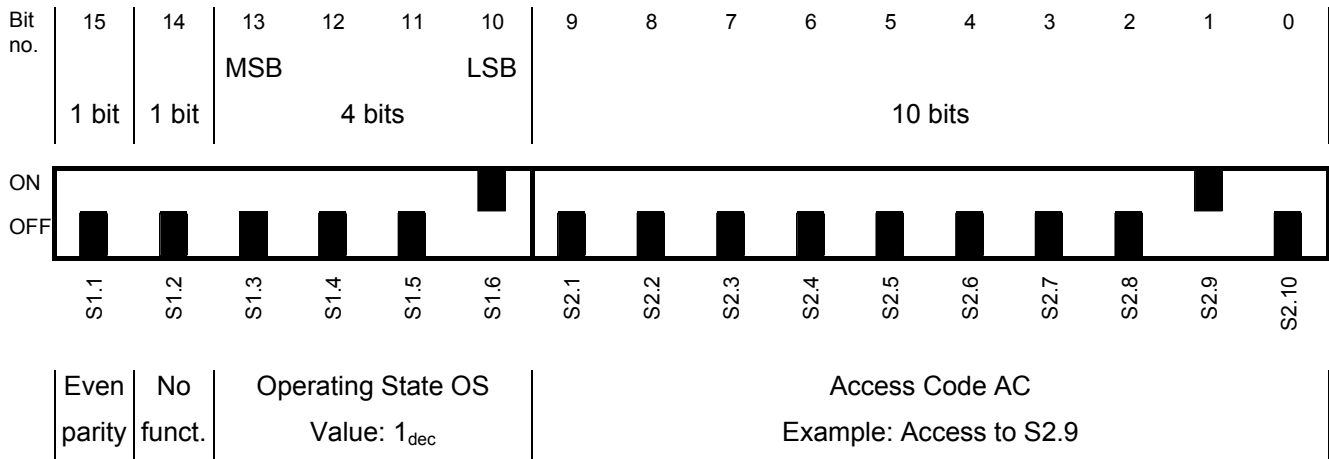

4.4.3 Operating state (OS) (bit nos. 10 to 13)

The operating state is set in binary form using switches S1.3 to S1.6. The value is always 1 for operating state 1; only the switch S1.6 is therefore set to ON.

4.4.4 Access code (AC) (bit nos. 0 to 9)

The access code is set in binary form using switches S2.1 to S2.10. The switches set to ON are evaluated. An access code therefore results from the bit pattern of the set bits (switch S2.1 and/or S2.2 and/or S2.3 ... S.10 to ON).

4.4.5 Data on the Electronic-Key in operating state 1

In an EKS *Light* data block with a length of 6 bytes, the following elements are stored on the Electronic-Key from Electronic-Key byte no. 110:

- ▶ the EKS operating state (OS) with the value 1 (input via EKM).
- ▶ an access code (AC) from the bit pattern of the set bits (click on positions S2.1 and/or S2.2 and/or S2.3 ... S.10 on the input mask) (input via EKM).
- ▶ an access level (AL) with the value 0 to 15 (input via EKM)
- ▶ a cyclic redundancy check (CRC) (automatically generated via EKM)
- ▶ a serial number (fix coded)

Block byte no.:															0	1
Key byte no.:	96	97	98	99	100	101	102	103	104	105	106	107	108	109	110	111
Value [dec]:																
Value [hex]:																
Function:	freely available for further EKS application														used...	
Block byte no.:	2	3	4	5												
Key byte no.:	112	113	114	115	116	117	118	119	120	121	122	123				
Value [dec]:																
Value [hex]:					01	1A	1E	F1	02	00	10	32				
Function:	...for operating state 1				Serial number (sample values)											

4.4.6 User access in operating state 1

Prerequisites for user access

1. Operating state 1 (value 1) is set on the device using DIP switch.
2. Access code (bit pattern) is set on the device using DIP switch.
3. Parity bit check within the DIP switches in the device is conclusive.
4. Operating state 1 (value 1) is programmed on the Electronic-Key via EKM.
5. Access code (bit pattern) is programmed on the Electronic-Key via EKM.
6. Access level (value 0 to 15) is programmed on the Electronic-Key via EKM.

Conditions for user access

1. Values for operating state in the device and on the Electronic-Key match.
2. Individual bits of the access code in the device and on the Electronic-Key match.
3. Cyclic redundancy check is conclusive.

Issuance of user access

1. Strobe output is statically set to High level.
2. Access level (value 0 to 15) is statically set to 4-bit data output.

5 Technical data

5.1 Dimension drawing of Electronic-Key adapter compact

For installation in a control panel you must provide a cut-out 33 mm x 68 mm according to DIN 43700.

5.1.1 Version EKS-A-IP...

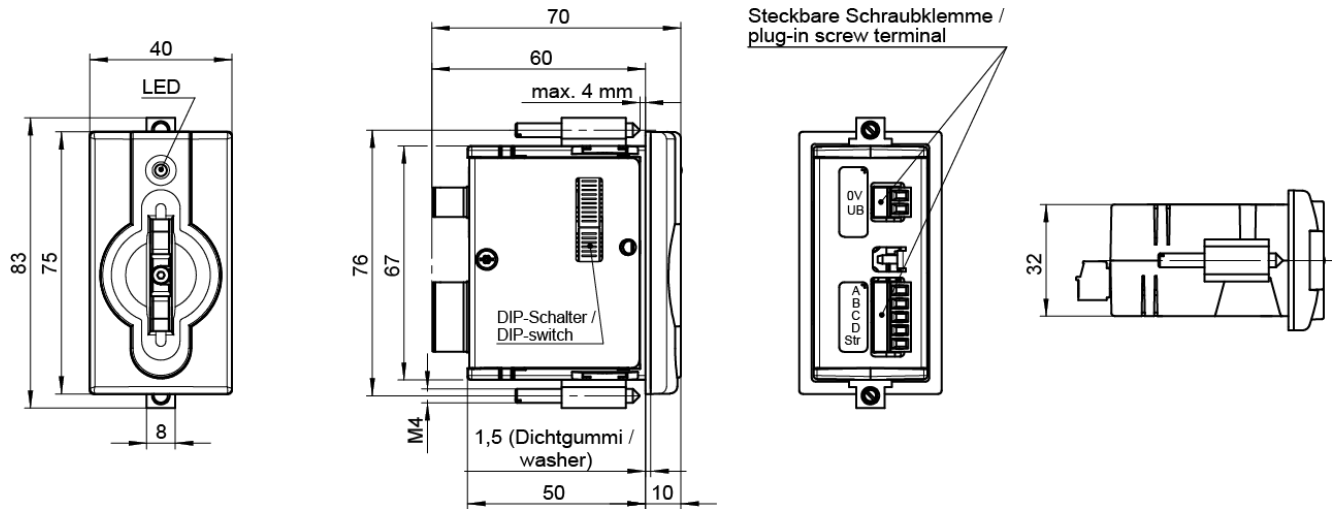

5.1.2 Version EKS-A-IP... FSA

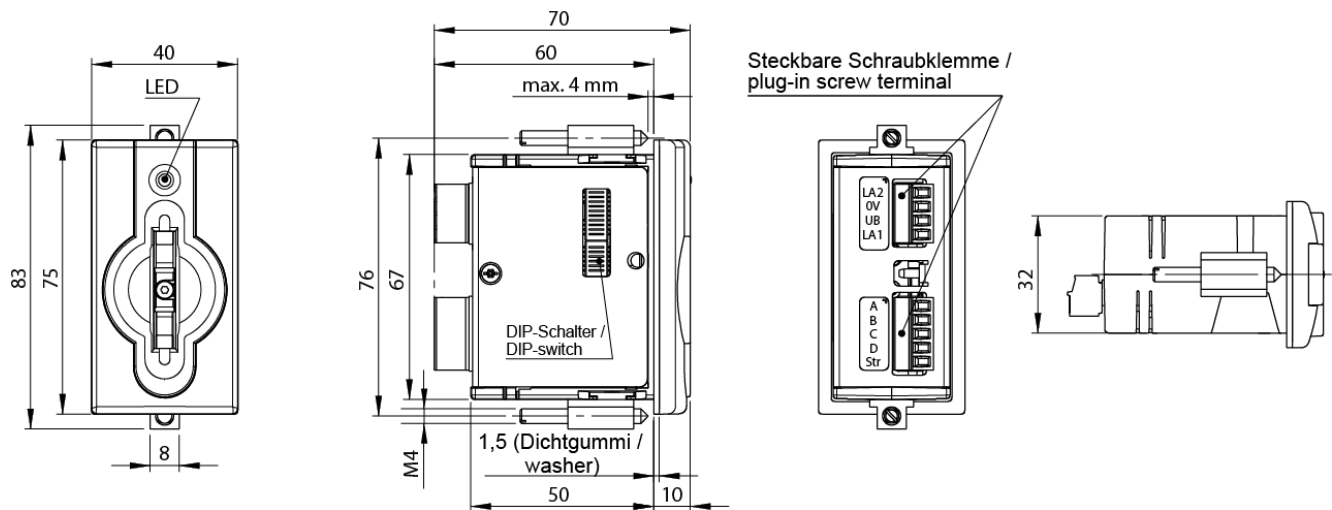

5.2 Dimension drawing of FHM Electronic-Key adapter modular

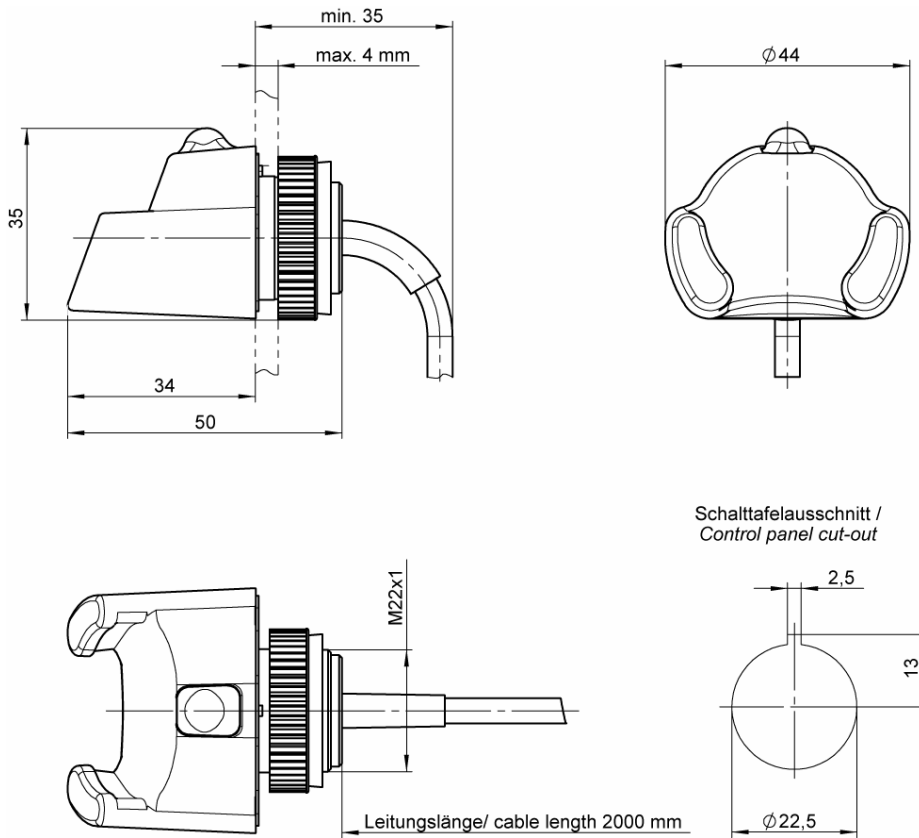

5.3 Dimension drawing of interface adapter modular

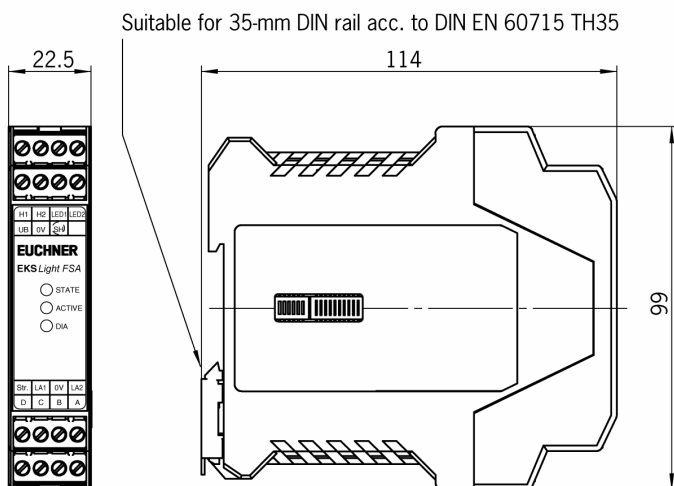

5.4 Technical data



Attention!

All the electrical connections must either be isolated from the mains supply by a safety transformer according IEC 61558-2-6 with limited output voltage in the event of a fault, or by other equivalent isolation measures. Pin 0V of the supply voltage is electrically connected to the housing in the compact version.

	Value			Unit
	min.	typ.	max.	
General parameters of Electronic-Key adapter compact				
Housing	Plastic (PA 6 GF30 gray/black)			
Degree of protection according to EN 60529	IP 65, IP 67 in mounted condition			
Ambient temperature at $U_B = DC 24 V$	-20		+ 70	°C
Mounting cut-out acc. to DIN 43700	33 x 68			mm
Connection type for power supply, outputs and semiconductor switching contact (FSA)	2 plug-in screw terminals, 2- and 5-pole 2 plug-in screw terminals, 4- and 5-pole (FSA version) Conductor cross section 0.14 ... 1.5 mm ² , tightening torque 0.22 Nm			
General parameters of Electronic-Key adapter Front Hook Modular FHM				
Housing	Plastic (PVDF GF30 gray)			
Degree of protection according to EN 60529	IP 65, IP 67, IP 69K in installed state			
Ambient temperature	-20		+70 /+100*	°C
Mounting hole	Ø 22.5			mm
Connection	Cable fixed to Electronic-Key adapter, with flying lead			
Connection cable length	2			m
Connection cable cross-section	4 x 0.25 screened			mm ²
Connection cable outer sheath	PVC			
General parameters of interface adapter modular				
Housing	Plastic (PA 6.6)			
Ambient temperature at $U_B = DC 24 V$	-20		+70	°C
Mounting	35-mm DIN rail acc. to DIN EN 60715 TH35			
Connectable Electronic-Key adapter	1			
Connection type for power supply, outputs, Electronic-Key adapter and semiconductor switching contact (FSA)	4 plug-in screw terminals, 4-pole, Conductor cross-section 0.14 ... 2.5 mm ²			
Cable length to Electronic-Key adapter		2	15	m
Electronics, interface and signaling				
Operating voltage U_B (regulated, residual ripple < 5 %)	9	24	28	DC V
Current consumption I_B (without load current)			70	mA
Interface to inputs of control system or switch unit	4-bit parallel plus strobe, binary coded via High/Low level			
Load current per output I_A	1	10	50	mA
Output voltage U_A (High level) for A,B,C,D, strobe	$U_B - 2$		U_B	V
Cable length to control			50	m
LED indicator	green "Ready" (in operation) yellow "Electronic-Key active" ** red "Error"			
FSA version (For Safety Applications) – parameters for floating semiconductor switching contact LA				
Power supply for load U (LA)		24	30	V
Switching current (with overload protection)	1	10	50	mA
Output voltage U_A (LA) in switched state	$U \times 0.9$		U	V
Resistance in switched state		35		Ohm
Capacitive load			1	µF
Utilization category according to EN IEC 60947-5-2	AC-12 AC-15 DC-12 DC-13	50 mA / 24 V		
Reliability values according to EN ISO 13849-1 (only FSA version)				
Category (with connected safe evaluation)	3			
MTTF _d	200			years
DC	92			%

* This is not the ambient temperature for operation. It is valid for a time duration of max. 3 minutes, e.g. for cleaning purposes.

** The LED illuminates yellow if there is a valid Electronic-Key in the Electronic-Key adapter.

5.5 Connector assignment for compact version

5.5.1 Plug-in screw terminals of the interface (4-bit parallel plus strobe)

Information!



The coded plug for connection of the data interface is included with the Electronic-Key adapter.

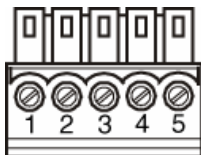

Coded plug, 5-pole with screw terminals
Conductor cross-section 0.14 ... 1,5 mm²
Tightening torque 0.22 Nm

Pin	Designation	Function
1	Strobe	Output is High if a valid Electronic-Key is inserted
2	D	High corresponds to decimal value of 8 (MSB)
3	C	High corresponds to decimal value of 4
4	B	High corresponds to decimal value of 2
5	A	High corresponds to decimal value of 1 (LSB)

5.5.2 Plug-in screw terminals for power supply

Information!



The coded plug for connection of the power supply is included with the Electronic-Key adapter.



Coded plug, 2-pole with screw terminals
Conductor cross-section 0.14 ... 1,5 mm²
Tightening torque 0.22 Nm

Pin	Designation	Function
1	U _B	Power supply DC + 24 V
2	0V	Power supply DC 0 V

5.5.3 Plug-in screw terminals for power supply and switching contact LA (only FSA version)

Information!



The coded plug for connection of the power supply and switching contact LA is included with the Electronic-Key adapter.

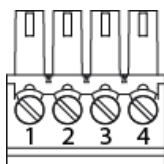

Coded plug, 4-pole with screw terminals
Conductor cross-section 0.14 ... 1,5 mm²
Tightening torque 0.22 Nm

Designation	Pin	Function
LA1	1	Normally open contact channel LA
LA2	4	
U _B	2	Power supply DC + 24 V
0V	3	Power supply DC 0 V

5.6 Connector assignment for interface adapter modular

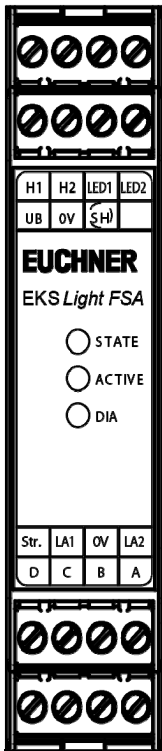

5.6.1 Connection to FHM Electronic-Key adapter

Designation	Function	Wire color
H1	Antenna of FHM Electronic-Key adapter	BN
H2	Antenna of FHM Electronic-Key adapter	WH
LED1	LED of FHM Electronic-Key adapter	YE
LED2	LED of FHM Electronic-Key adapter	GN
SH	Shield of FHM Electronic-Key adapter	BK

5.6.2 Power supply, interface (4-bit parallel plus strobe) and switching contact LA (FSA version only)

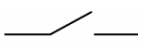
Designation	Function
U _B	Supply voltage DC + 24 V
0V	Power supply DC 0 V
Str.	The strobe output is High if there is a valid Electronic-Key in the Electronic-Key adapter.
D	High corresponds to decimal value of 8 (MSB)
C	High corresponds to decimal value of 4
B	High corresponds to decimal value of 2
A	High corresponds to decimal value of 1 (LSB)
LA1	 Normally open contact channel LA
LA2	

5.7 LED indicator

The operating status of the Electronic-Key adapter is indicated via the LED on the front by means of three colors in combination with static illumination or illumination in various flashing sequences.

Signaling and flashing sequences in normal operation and in the event of errors:

Color	Signal	Operating state	Description
green	static	Ready	Key adapter is ready.
yellow	static	Electronic-Key active, access	A valid Electronic-Key is in the Electronic-Key adapter, and user access is approved.
green/yellow w	flashing	no access	The access code programmed on the Electronic-Key does not match the access code setting in the device. Check the Electronic-Key programming and the setting of the DIP switch.
green/yellow w	flashing 1x briefly yellow	no access	Checksum (CRC) is not conclusive. Check the Electronic-Key programming. There may have been a tampering attempt.
green/yellow w	flashing 2x briefly yellow	no access	The operating state programmed on the Electronic-Key does not match the operating state setting in the device. Check the Electronic-Key programming and the setting of the DIP switch.
green/yellow w	flashing 3x briefly yellow	no access	The access level programmed on the Electronic-Key does not match a value possible in the current operating state.

The device will enter the fault state if the following errors occur:

Color	Signal	Operating state	Description
red	flashing 1x briefly	no access	Reserved for future application. Check the settings of the DIP switch.
red	flashing 2x briefly	no access	The parity bit check within the DIP switch in the device is not conclusive. Check the settings of the DIP switch.
red	flashing 3x briefly	no access	The operating state set on the DIP switch is not available. Check the DIP switch settings.
red	flashing $\geq 4x$ briefly	no access	Device defect (hardware). Please return device for checking to Euchner.

Information!

 In order to terminate the fault state the device must be restarted. Interrupt the power supply for at least 2 seconds.

The operating status of the interface adapter is additionally signaled by means of three LEDs in three colors:

Color	Designation	Description
green	STATE	Interface adapter ready
yellow	ACTIVE	Signaling of Electronic-Key recognition as described in the table above.
red	DIA	Diagnostics, signaling of an error as described in the table above.

6 Mounting



Warning!

Mounting must be performed only by authorized personnel.

After mounting, again check the Electronic-Key adapter for firm seating and correct sealing of the front panel.

6.1 Electronic-Key adapter compact



Attention!

To achieve the degree of protection IP 67, it is necessary to install the Electronic-Key adapter in a clean, flat metal plate at least 2 mm thick and to tighten the screws with a tightening torque of 0.25 ... 0.35 Nm.

A suitable strain relief must be provided for the connection cables in order to avoid damage to the connection sockets or malfunctions.

The Electronic-Key adapter is intended for mounting in control panels with a cut-out measuring 33 mm x 68 mm according to DIN 43700 (see section 5.1). The device is fastened using screw clamp elements from the rear side of the panel.



Information!

The screw clamp elements for front panel mounting are included with the Electronic-Key adapter.

1. Insert Electronic-Key adapter, **with seal already bonded in place**, into the mounting cut-out from the front.
2. Insert screw clamp elements in the housing of the Electronic-Key adapter from the side up to the stop and tighten with 0.25 ... 0.35 Nm.



Attention!

The device may be damaged if the tightening torque applied exceeds 0.35 Nm.

6.2 Electronic-Key adapter FHM



Attention!

To achieve the degree of protection IP 69K, it is necessary to install the FHM Electronic-Key adapter in a clean, flat metal plate at least 2 mm thick and to tighten the central fixing nut with a tightening torque of 2 Nm.

A suitable strain relief must be provided for the connection cables in order to avoid damage to the connection sockets or malfunctions.

The Electronic-Key adapter is intended for mounting in control panels with a cut-out \varnothing 22.5 mm (see section 5.2).

7 Electrical connection

**Danger!**

Electrical connection may only be performed by **authorized personnel trained in EMC** and with the device and wiring **isolated**.

**Warning!**

For use and operation as per the **UL** requirements, a power supply **for use in class 2 circuits** must be used.

**Attention!**

The read station is only allowed to be connected if it is electrically isolated. Otherwise the read station may be damaged.

**Attention!**

If connected incorrectly, the read station may be damaged. Observe the electrical characteristics (see section 5.4 Technical data) and terminal assignment.

In order to avoid overvoltages at the inputs and outputs, inductive loads must be connected with freewheeling diodes or other protective devices, for example.

**Attention!**

All the electrical connections must either be isolated from the mains supply by a safety transformer according to IEC/EN 61558-2-6 with limited output voltage in the event of a fault, or by other equivalent isolation measures.

Pin 0V of the supply voltage is electrically connected to the housing in the compact version.

**Attention!**

When installing connections, the operating organization must ensure compliance with the EMC safety requirements in accordance with EN 55011 and EN 61000-6-2.

**Attention!**

The equipotential bonding system of the machine installation must comply with EN 60204-1, section 8, Equipotential bonding.

**Attention!**

Do not lay connection cables in the immediate vicinity of sources of interference.

7.1 Interface

The parallel interface is easy to integrate into the control environment, and the data can be depicted in a transparent manner. This allows rapid and inexpensive integration into any type of programmable logic controller.

Communication with the peripheral equipment takes place exclusively via these switched outputs, which can engage the states High and Low. All outputs are at Low level after the device is switched on.

The strobe output is set to High level when an Electronic-Key receives access via a valid access code.

The access level is output via the 4-bit parallel interface. The four data wires, which can be connected directly to the inputs of a programmable logic controller, for example, represent values between 0 and 15 via High/Low levels (24 V/0 V).

A binary-coded value between decimal 0 and 15 is represented via combinations of High/Low levels at the data outputs. The values result as follows:

Output A = High corresponds to decimal value of 1 (LSB)

Output B = High corresponds to decimal value of 2

Output C = High corresponds to decimal value of 4

Output D = High corresponds to decimal value of 8 (MSB)

Therefore, if the outputs A, B and C, for example, are set to High level when the Electronic-Key is placed; this corresponds to an access level of $1 + 2 + 4 = 7$.

7.2 Connection of power supply

It is imperative that the following points are observed:

- ▶ The connections must be made as appropriate to maintain EMC performance.
- ▶ A power supply of suitable EMC performance must be used for the power supply.
- ▶ Conductor cross-section max. 1.5 mm² (Electronic-Key adapter compact).
- ▶ Conductor cross-section max. 2.5 mm² (interface adapter modular).
- ▶ Tighten the terminal screws on the plug to 0.22 Nm (Electronic-Key adapter compact).

7.3 Connection of semiconductor switching contact LA1/LA2 (only for EKS *FSA*)

**Warning!**

Incorrect connection or errors in the safety-related integration of the EKS *FSA* can lead to fatal injury. For this reason, observe the following safety aspects:

- ▶ The safe evaluation must always be dual-channel. It is not possible to produce a safe signal solely using outputs A, B, C, D and strobe plus switching contact LA1/LA2. Safe, downstream evaluation is always necessary (e. g. using a safety relay or safe control system).
- ▶ The overload protection of the semiconductor switching contact switches the switch off if the current load exceeds the permissible value of 50 mA (see section 5.4 Technical data). In order to exit this state, i.e. activate the switching contact again, the Electronic-Key must be removed and placed again.
- ▶ Integrate the EKS *FSA* as defined in the following connection examples from EUCHNER.

7.3.1 Connection example with enabling switch

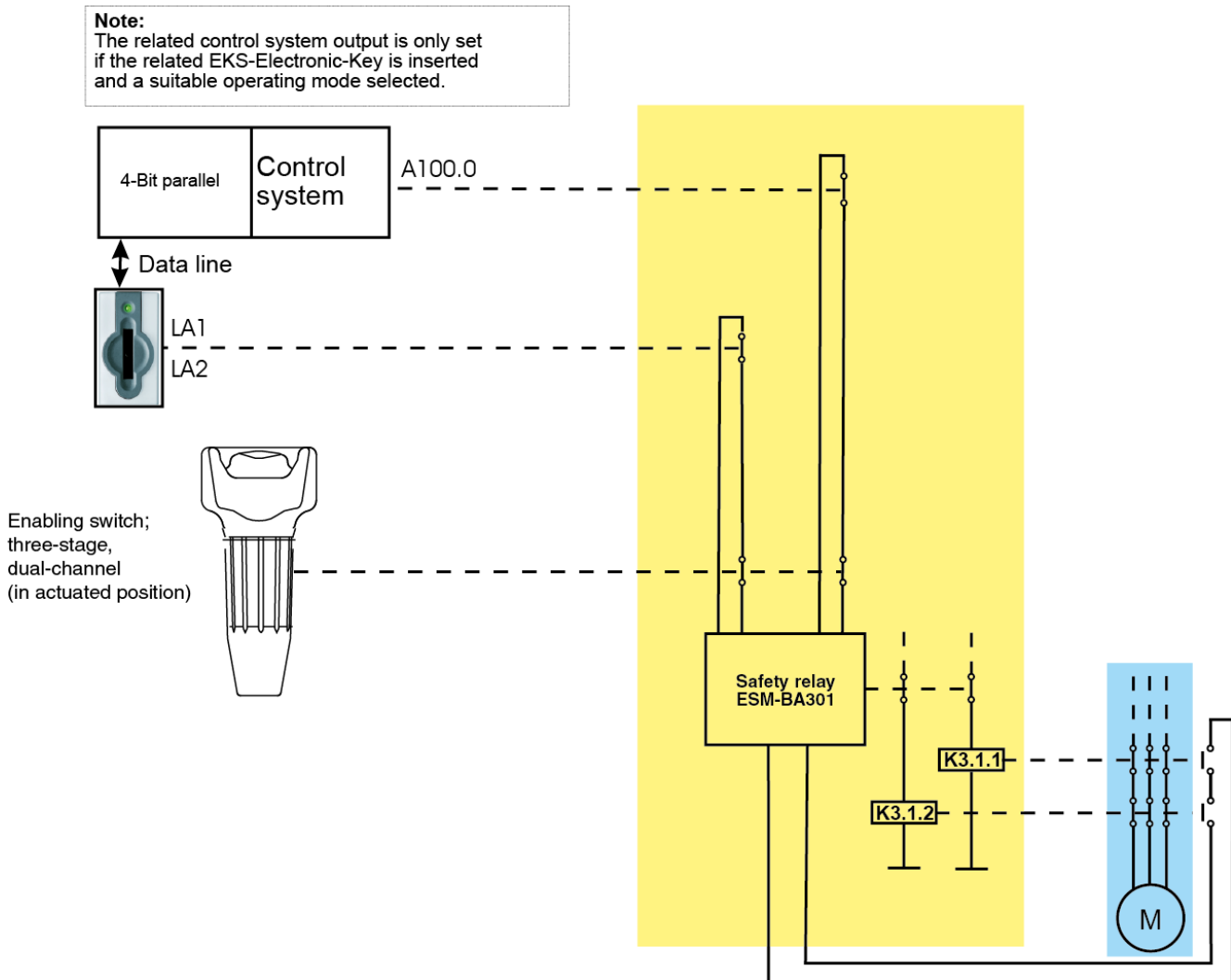

Figure 5: Principle of operation (illustration with selected operating mode and all components in actuated position). Only the compact Electronic-Key adapter is shown here as an example.

7.3.1.1 Description of the application example with enabling switch

The danger area on a machine is secured with a fence. To allow set-up work on the machine possible with the guard open, an EKS FSA system is integrated in conjunction with a control system, an enabling switch and a safety relay. The safety relay must comply with the following requirements:

- ▶ Detection of short-circuits and earth faults. A short-circuit can be detected in the safety path in the circuit described due to the fact that both the positive path and earth path of the safety relay are switched. In this case, the safety relay deactivates its safety outputs.
- ▶ Simultaneity monitoring: The safety relay must detect whether the safety inputs are switched practically simultaneously. If this is not the case, the safety outputs are not switched and the unit switches to fault state. A renewed start is possible only after the enabling switch has been released and then operated again.

The switching contact LA1/LA2 is closed after placement of the Electronic-Key. The EKS FSA is coupled with a control system. After placement of the Electronic-Key, the control system checks whether the Electronic-Key is authorized for work in the selected operating mode. If this is not the case, the operating mode cannot be set. If suitable access rights are available, the control system gives the instruction to the switching contact A100.0 to close.

The switching contact LA1/LA2 of the EKS *FSA*, in series with a switching contact on the enabling switch, is connected to the first input on the safety relay. The switching contact A100.0 is connected to the second input on the safety relay in series with the second switching contact on the enabling switch. The result is that these inputs on the safety relay are only enabled if

- ▶ the EKS *FSA* (switching contact LA1/LA2) and
- ▶ the control system (switching contact A100.0) issue the related enabling signal and
- ▶ the enabling switch is actuated.

The output contacts on the safety relay are enabled only after actuation of the enabling switch. The safety relay is de-energized without a time delay (stop category 0) and the machine movement is stopped if

- ▶ the Electronic-Key is removed or
- ▶ the enabling switch is released or
- ▶ the machine control system cancels the enable state (contact A100.0 is opened).

Note: The control system output A100.0 is only allowed to be set

- ▶ if the related Electronic-Key is inserted and
- ▶ a suitable operating mode is selected.

7.3.1.2 Feedback loop

The safety relay can be started only with the feedback loop closed. A welded contactor contact in the enable path will thus be detected when a start request is made and a start is then prevented. The power contactor must have positively driven contacts.

7.3.1.3 Start

The safety relay start takes place after enabling by the EKS *FSA* and by the control system, and after operation of the enabling switch.

7.3.1.4 Circuit diagram

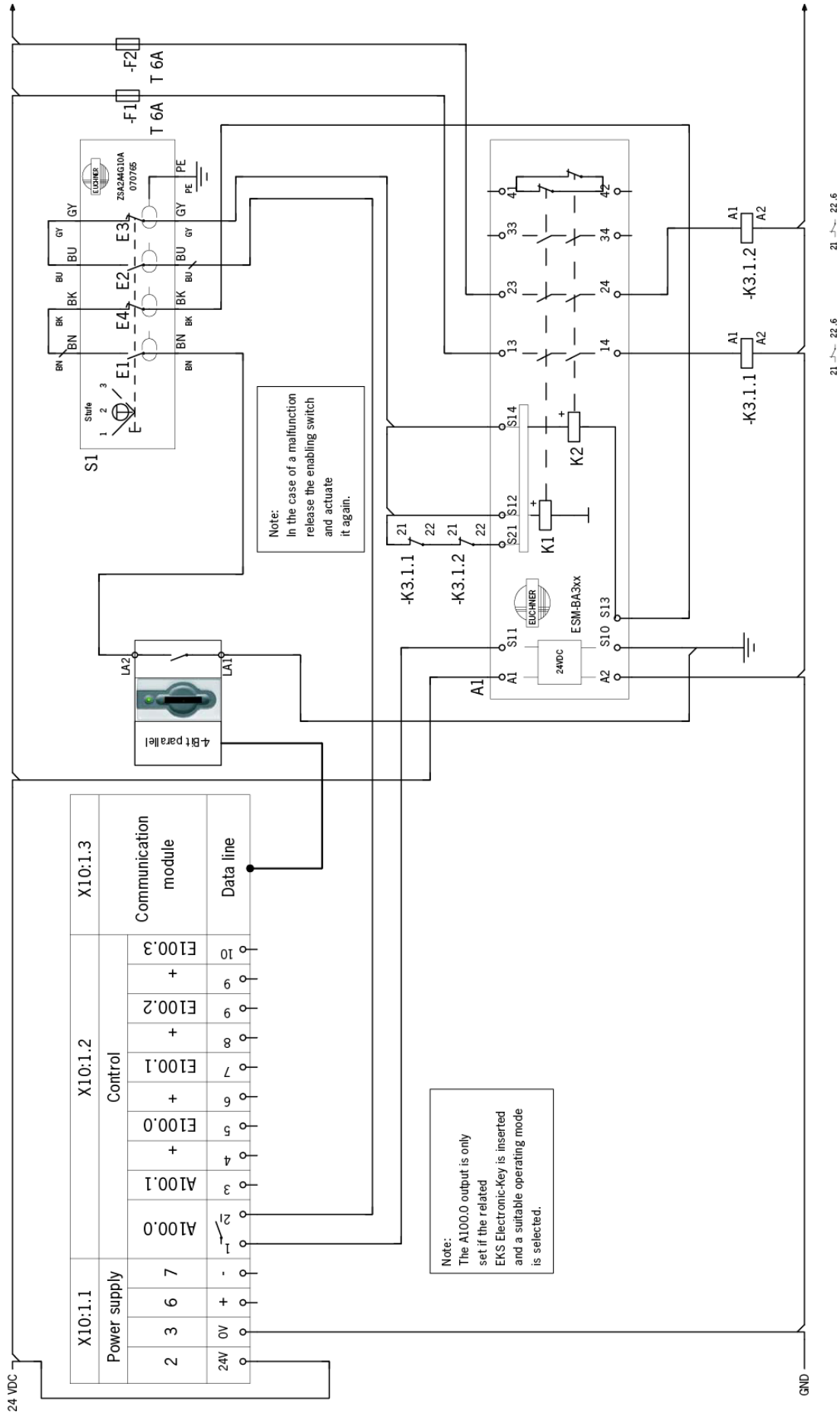

Figure 6: Circuit diagram with enabling switch

7.3.2 Connection example without enabling switch

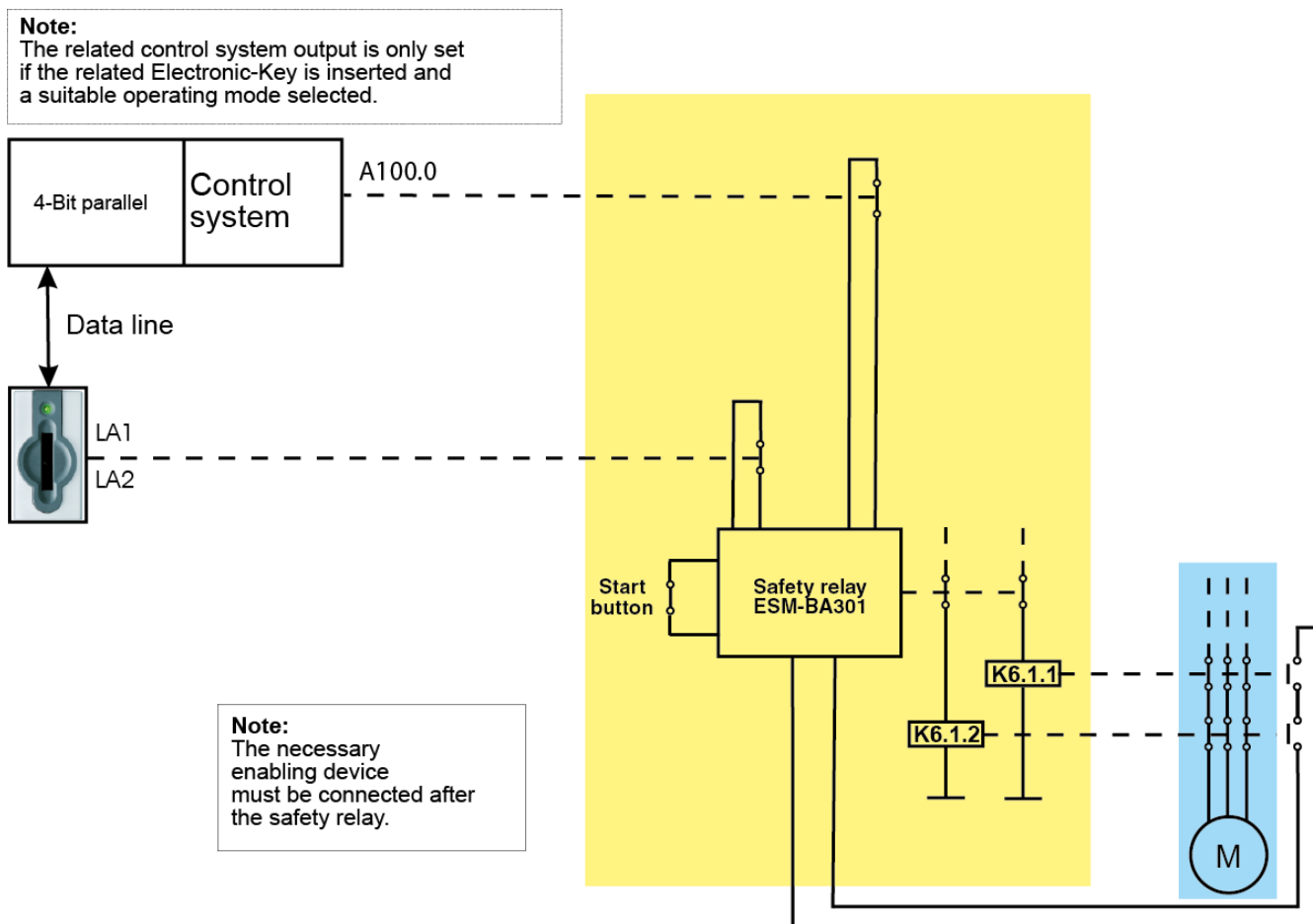

Figure 7: Principle of operation (illustration with selected operating mode and all components in actuated position). Only the compact Electronic-Key adapter is shown here as an example.

7.3.2.1 Description of the application example without enabling switch

The danger area on a machine is secured with a fence. To allow set-up work on the machine possible with the guard open, an EKS *FSA* system is integrated in conjunction with a control system and a safety relay. The safety relay must comply with the following requirements:

- ▶ Detection of short-circuits and earth faults. A short-circuit can be detected in the safety path in the circuit described due to the fact that both the positive path and earth path of the safety relay are switched. In this case, the safety relay deactivates its safety outputs.
- ▶ Simultaneity monitoring: The safety relay must detect whether the safety inputs are switched practically simultaneously. If this is not the case, the safety outputs are not switched and the unit switches to fault state. A renewed start is possible only after the Electronic-Key has been inserted again.
- ▶ Start button monitoring: The safety relay must detect when the start button is welded or jammed at the latest at the next start. If this is the case, the safety outputs are not switched and the unit switches to fault state. This prevents accidental starting of the system.

The switching contact LA1/LA2 is closed after placement of the Electronic-Key. The EKS *FSA* is coupled with a control system. After placement of the Electronic-Key, the control system checks whether the Electronic-Key is authorized for work in the selected operating mode. If this is not the case, the operating mode cannot be set. If suitable access rights are available, the control system gives the instruction to the switching contact A100.0 to close.

The switching contact LA1/LA2 of the EKS *FSA* is connected to the first input on the safety relay. The switching contact A100.0 on the control system is connected to the second input on the safety relay. The control contact A100.0 and the switching contact LA1/LA2 are monitored for simultaneity.

The safety relay is de-energized without a time delay (stop category 0) and the machine movement is stopped if

- ▶ the Electronic-Key is removed or
- ▶ the machine control system cancels the enable state (switching contact A100.0 is opened).

Note: The switching contact A100.0 is only allowed to be set

- ▶ if the related Electronic-Key is inserted and
- ▶ a suitable operating mode is selected.

7.3.2.2 Feedback loop

The safety relay can be started only with the feedback loop closed. A welded contactor contact in the enable path will thus be detected when a start request is made and a start is then prevented. The power contactor must have positively driven contacts.

7.3.2.3 Start

The safety relay start takes place after enabling by the EKS *FSA* and by the control system, and after operation of the start button.

7.3.2.4 Circuit diagram

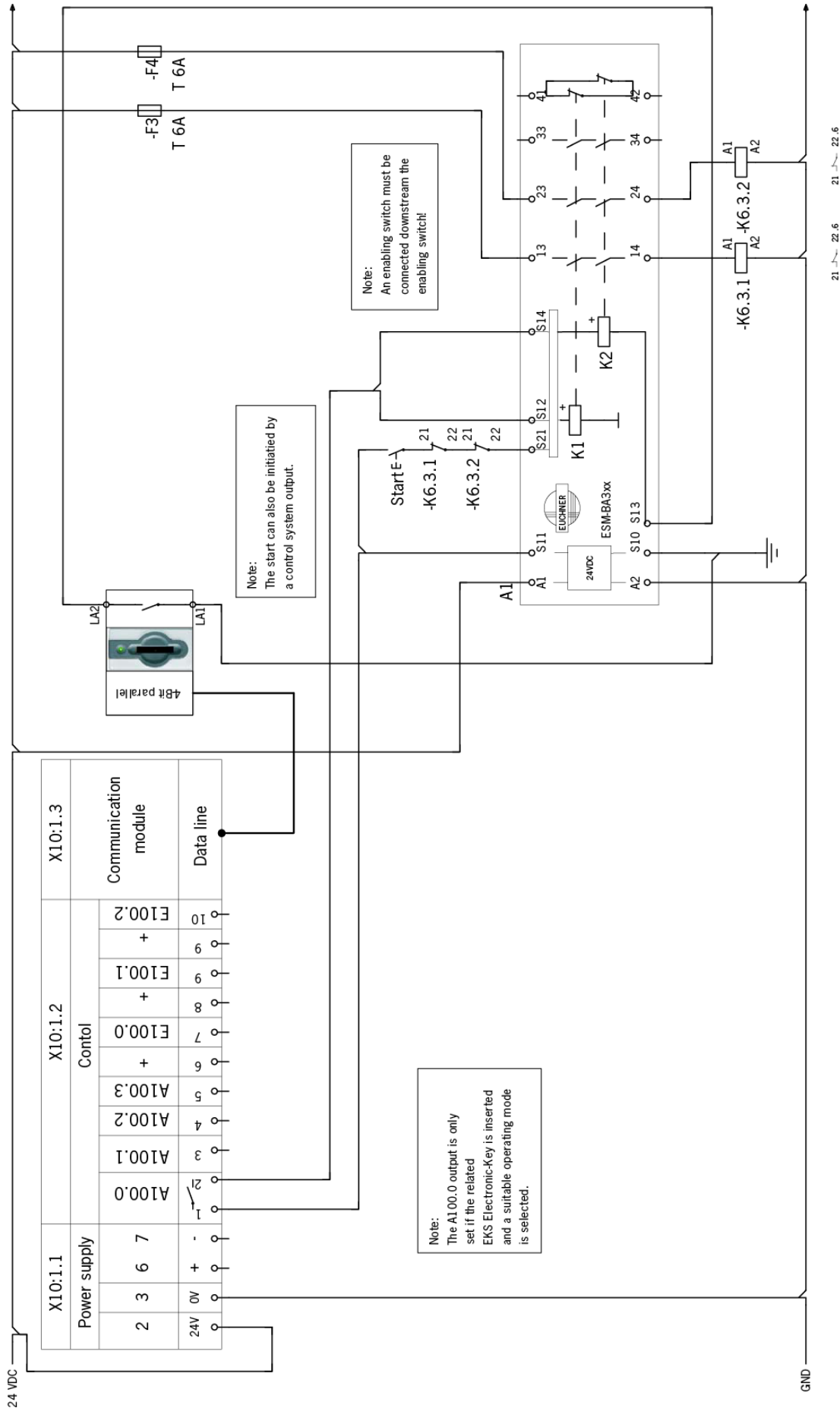

Figure 8: Circuit diagram without enabling switch.

8 Parameter assignment of the Electronic-Keys via the Electronic-Key-Manager EKM software

EKM input mask for the operating states (OS) 0 and 1

The screenshot shows the EKM - Light version software interface. The window title is "EKM - Light version". The menu bar includes "File", "Edit", "Tools", and "Help". The toolbar contains "Read", "Write", and "Discard" buttons, along with the EUCHNER logo. The main interface is divided into several sections:

- EKS Operating State OS:** A dropdown menu set to "00".
- Electronic-Key Information:** Two input fields: "Serial Number" (01C59F15A5001032) and "CRC" (1813).
- Employee:** A form with "Last Name" (Brandt), "First Name" (Brigitte), and "Issue Date" (02.08.2010).
- Access:** A section with "Access Code AC" (2.1 to 2.10) and "Reserve R - must be set all OFF" (6 checkboxes, all unchecked). Below it is "Access Level AL" (07).
- Remark:** A text area containing "User access in assembly line 7".

The status bar at the bottom shows "Port COM5" and "ekm".

The values entered here correlate with the sample DIP switch setting in operating state 0 (see section 4.3.2 DIP switch settings in operating state 0).

The input mask can be customized with the aid of the Electronic-Key-Manager software.

Perform Electronic-Key parameter assignment in the following sequence:

1. Select desired value for the operating state (OS).
2. Input the desired access code (AC) in binary form according to the DIP switch nomenclature. Important: It is essential to set the reserve bits R to OFF (as shown in the Figure above). Remove the tick from the check boxes if necessary.
4. Select the desired access level (AL).
5. Further administrative inputs, such as the employee name, issue date or remarks, are optional and are not necessary for the function of EKS *Light*.
6. Write data onto the Electronic-Key.

9 Setup

Perform setup in the following sequence:

1. Set the DIP switches on the read station (see section 4.1 Function of the DIP switches).
2. Check mounting and electrical connection are correct (see section 6 and section 7).
 - ▶ After connection of the power supply, the LED on the front of the Electronic-Key adapter illuminates.
3. Insert valid Electronic-Key into the Electronic-Key adapter.
 - ▶ The LED illuminates yellow if there is a functional Electronic-Key in the Electronic-Key adapter.

10 Exclusion of liability

Exclusion of liability under the following conditions:

- ▶ incorrect use
- ▶ non-compliance with safety regulations
- ▶ if mounting and electrical connection are carried out by unauthorized personnel
- ▶ if modifications are made

11 Service and repair

- ▶ No servicing is required.
- ▶ Remove dirt from the Electronic-Key and the Electronic-Key adapter using a soft cloth and solvent-free, non-abrasive cleaning agents.
- ▶ Repairs must be performed only by the manufacturer.

12 Guarantee

The "General Terms and Conditions" of EUCHNER GmbH + Co. KG apply.

Microsoft Windows® is a registered
trademark of Microsoft Corporation

More than safety.



EUCHNER GmbH + Co. KG
Kohlhammerstraße 16
D-70771 Leinfelden-Echterdingen

Telephone +49 711 7597-0
Fax +49 711 753316
www.euchner.de · info@euchner.de

EUCHNER