

Correct use

The ESM-2H2.. is an extremely compact, universal two-hand safety device. It complies with EN ISO 13851, type III C, and is intended for use in safety circuits that are designed according to EN60204-1, e.g. on presses, punches and bending tools.

Due to the internal error monitoring, the ESM-2H2.. can, despite its very compact dimensions, be used for all applications up to the highest category, safety category 4, PL e according to 13849-1, SILCL 3 according to EN62061 or type III C according to EN ISO 13851.

Before the device is used, a risk assessment must be performed on the machine, e.g. according to the following standards:

- ▶ EN ISO 13849-1
- ▶ EN ISO 12100
- ▶ IEC 62061.

Correct use includes observing the relevant requirements for installation and operation, particularly based on the following standards:

- ▶ EN ISO 13849-1
- ▶ EN 60204-1
- ▶ IEC 62061.

Important!

- ▶ The user is responsible for the integration of the device in a safe overall system. For this purpose, the overall system must be validated, e.g. according to EN ISO 13849-2.
- ▶ The device user must assess and document remaining risks.
- ▶ If a data sheet is included with the product, the information on the data sheet applies.

Safety precautions

⚠ WARNING

- ▶ Installation and setup of the device must be performed only by authorized personnel.
- ▶ Observe the country-specific regulations when installing the device.
- ▶ The electrical connection of the device is only allowed to be made with the device isolated.
- ▶ The wiring of the device must comply with the instructions in these operating instructions, otherwise there is a risk that the safety function will be lost.
- ▶ It is not allowed to open the device, tamper with the device or bypass the safety devices.
- ▶ All relevant safety regulations and standards are to be observed.
- ▶ The overall concept of the control system in which the device is incorporated must be validated by the user.
- ▶ Failure to observe the safety regulations can result in death, severe injuries and serious damage.
- ▶ Note down the version of the device (see type label Vx.x.x) and check it each time prior to setup. If the version changes, the use of the device in the overall application must be validated again.

Features

- ▶ 2 safe, redundant relay outputs
- ▶ Cyclical monitoring of the output contacts
- ▶ Feedback loop for monitoring downstream contactors or expansion modules
- ▶ Short circuit and ground fault monitoring
- ▶ Extremely compact design
- ▶ Use up to PL e, SILCL 3, category 4 or type III C according to EN ISO 13851

Function

The two-hand relay ESM-2H2.. is suitable for setting up and monitoring two-hand circuits and is used to protect the operating personnel. Dangerous work steps can only be triggered when both two-hand buttons connected are actuated simultaneously, i.e. within 0.5 s.

It is ensured that a single fault or malfunction does not lead to a loss of the safety function and that every fault is detected by cyclical self-monitoring no later than the next actuation.

When the operating voltage is applied to A1 and A2 and the feedback loop X1 and X2 closed, the ESM-2H2.. is ready for use. To be able to initiate a switching operation, the output relays must be de-energized. The output relays only switch to the energized position when the two-hand buttons T1 and T2 are actuated simultaneously, i.e. within 0.5 s.

The output relays are not switched if:

- ▶ Only one two-hand button is actuated or the time between the actuation of the two two-hand buttons is > 0.5 s,
- ▶ The feedback loop is open (error in external contactor or expansion module),
- ▶ Another error (short circuit, cable break, error in the switching device) has occurred.

When T1 and/or T2 are/is released, the output relays are open (safe) immediately. In order to trigger a new operation, both two-hand buttons must first be released and the feedback loop must be closed.

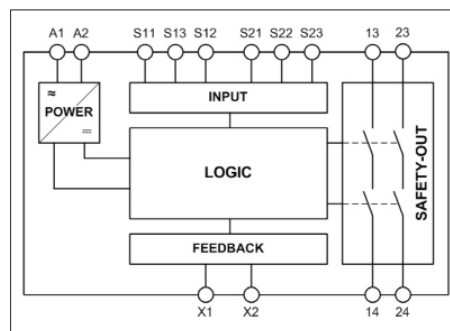

Fig. 1: Block diagram for ESM-2H2..

Mounting

As per EN 60204-1, the device is intended for installation in control cabinets with a minimum degree of protection of IP54. It is mounted on a 35 mm mounting rail according to DIN EN 60715 TH35.

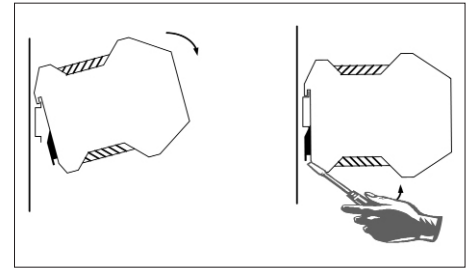

Fig. 2: Mounting/removing

Installation

Prevent unintentional actuation or bypassing of the safety function

The two-hand buttons must be arranged as per the standard EN ISO 13851 such that unintentional actuation or simple bypassing of the safety function is excluded. As such the operation of both buttons using one hand must be prevented by a sufficient distance (at least 260 mm) or by a separating wall.

Actuation using the forearm, elbow, knee, hip or other parts of the body can be effectively prevented by further increasing the distance between the two buttons, sufficient distance from the floor and/or covers and/or separating walls.

Distance between the two-hand buttons and the danger area

It is required that a minimum distance between the buttons for the two-hand circuit and the danger area of the machine or installation is maintained so that, after the release of one or both buttons, the danger area can only be reached when the dangerous movement has been interrupted or ended.

According to the standard DIN EN ISO 13855 this distance is calculated using the following equation:

$$S = (K \times T) + C$$

S: Minimum distance from the nearest pushbutton (two-hand button) to the danger area.

K: Parameter in mm/s, derived from data on the approach speed of the body or parts of the body, for two-hand circuits 1,600 mm/s.

T: The stopping time for the entire system in seconds, that is the time from the release of the two-hand buttons to the end of the dangerous movement.

C: Additional distance in mm related to intrusion into the danger area before the safeguard activates. For two-hand circuits this distance is 250 mm, if the buttons are covered appropriately it can also be set to 0 mm, however **S** must then be at least 100 mm.

Example

The stopping time of the overall system is 90 ms. Then from the above equation the minimum distance is:

$$S = (1,600 \text{ mm/s} \times 0.09 \text{ s}) + 250 \text{ mm}$$

$$S = 144 \text{ mm} + 250 \text{ mm} = 394 \text{ mm}$$

If a suitable cover is used, **S** can be reduced to 144 mm.

Electrical connection

- ▶ When the 24 V version is used, a safety transformer according to EN 61558-2-6 or a power supply unit with electrical isolation from the mains must be connected.
- ▶ External fusing of the safety contacts must be provided.
- ▶ A maximum length of the control lines of 1,000 m with a conductor cross-section of 0.75 mm² must not be exceeded.
- ▶ The conductor cross-section must not exceed 2.5 mm².
- ▶ If the device does not function after setup, it must be returned to the manufacturer unopened. Opening the device will void the warranty.

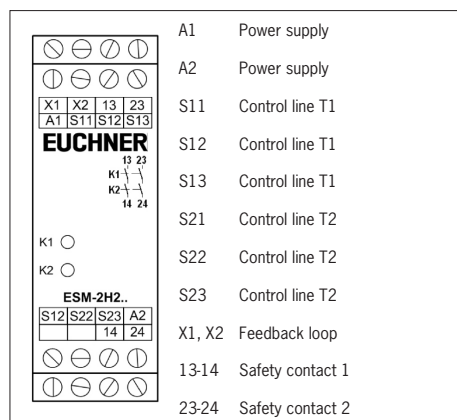

Fig. 3: Connections

Setup procedure

Notice

The items listed under *Electrical connection* must be observed during commissioning.

1. Wiring ESM-2H2.. to two-hand buttons:

Wire the ESM-2H2.. to the two-hand buttons as per Fig. 5.

2. Wiring feedback loop:

If your application provides for external contactors or expansion modules, connect them to the device according to Fig. 6.

3. Wiring power supply:

Connect the power supply to terminals A1 and A2 (see Fig. 7).

Attention: Wiring only in de-energized state.

4. Starting the device:

Switch the operating voltage on.

5. Switching to the operating status:

Actuate the two buttons T1 and T2 simultaneously, or within 0.5 s.

The positively driven relays switch on.

6. Switching to the idle status:

Release the two buttons T1 and T2.

The positively driven relays switch off.

What to do in case of a fault?

Device does not switch on:

- ▶ Check the wiring by comparing it to the wiring diagrams.
- ▶ Check the two-hand buttons used for correct function and adjustment.
- ▶ Check the operating voltage at A1 and A2.
- ▶ Is the feedback loop closed or a jumper fitted?

Device cannot be switched on again after an emergency stop:

- ▶ Check the two-hand buttons used for correct function.
- ▶ Check the wiring (short circuits or similar?)
- ▶ Is the feedback loop closed?

If the fault persists, perform the steps listed under *Setup procedure*.

If these steps do not remedy the fault either, return the device to the manufacturer for examination.

Opening the device is impermissible and will void the warranty.

Maintenance

The device must be checked once per month for proper function and for signs of tampering and bypassing of the safety function. The device is otherwise maintenance-free, provided that it was installed properly.

Disposal

Pay attention to the applicable national regulations and laws during disposal.

EU declaration of conformity

The declaration of conformity is part of the operating instructions, and it is included as a separate sheet with the device.

The EU declaration of conformity can also be found at: www.euchner.com

Service

If servicing is required, please contact:

EUCHNER GmbH + Co. KG
Kohlhammerstraße 16
70771 Leinfelden-Echterdingen
Germany

Service telephone:
+49 711 7597-500

E-mail:
support@euchner.de

Internet:
www.euchner.com

Technical data

Parameter	Value		
	ESM-2H201	ESM-2H202	ESM-2H203
Version	ESM-2H201	ESM-2H202	ESM-2H203
Operating voltage	AC/DC 24 V	AC 115 V	AC 230 V
Rated supply frequency	50 - 60 Hz		
Permissible deviation	± 10%		
Power consumption	DC 24 V Approx. 1.5 W	AC 230 V Approx. 3.7 VA	
Control voltage at S12/S13 and S22/S23	DC 24 V		
Control current (both buttons)	Approx. 2 x 40 mA		
Release time of the safety relay after releasing a button	< 20 ms		
Response delay after actuation of the buttons	< 20 ms		
Synchronization time	< 0.5 s		
Safety contacts	2 NO contacts		
Max. switching voltage	AC 250 V		
Breaking capacity	AC: 250 V, 1,500 VA, 6 A for ohm resistive load (6 operating cycles/minute) 250 V, 3 A for AC-15 DC: 24 V, 144 W, 6 A for ohm resistive load (6 operating cycles/minute) 24 V, 3 A, for DC-13		
Minimum contact load	24 V, 20 mA		
Contact fuses	10 A gG		
Conductor cross-section	0.14 - 2.5 mm ²		
Max. length of control cable	1,000 m with 0.75 mm ²		
Contact material	AgSnO ₂		
Mech. contact life	Approx. 1 x 10 ⁷		
Test voltage	2.5 kV (control voltage/contacts)		
Rated impulse withstand voltage, leakage paths/air gaps	4 kV (DIN VDE 0110-1)		
Rated insulation voltage	250 V		
Degree of protection	IP20		
Temperature range	DC 24 V: -15 °C to +60 °C AC 230 V/115 V/24 V: -15 °C to +40 °C		
Degree of contamination	2 (DIN VDE 0110-1)		
Overvoltage category	3 (DIN VDE 0110-1)		
Weight	Approx. 230 g		
Mounting	Mounting rail according to DIN EN 60715 TH35		
Reliability values according to EN ISO 13849-1 for all variants of the series ESM-2H2¹⁾			
Load (DC-13; 24 V)	≤ 0.1 A	≤ 1 A	≤ 3 A
n _{op}	≤ 400,000 cycles	≤ 100,000 cycles	≤ 22,500 cycles
T _{10D}	20 years		
Category	4		
PL	e		
PfH _D	1.2 x 10 ⁸ 1/h		

1) Additional data can be requested from the manufacturer for applications that deviate from these conditions.

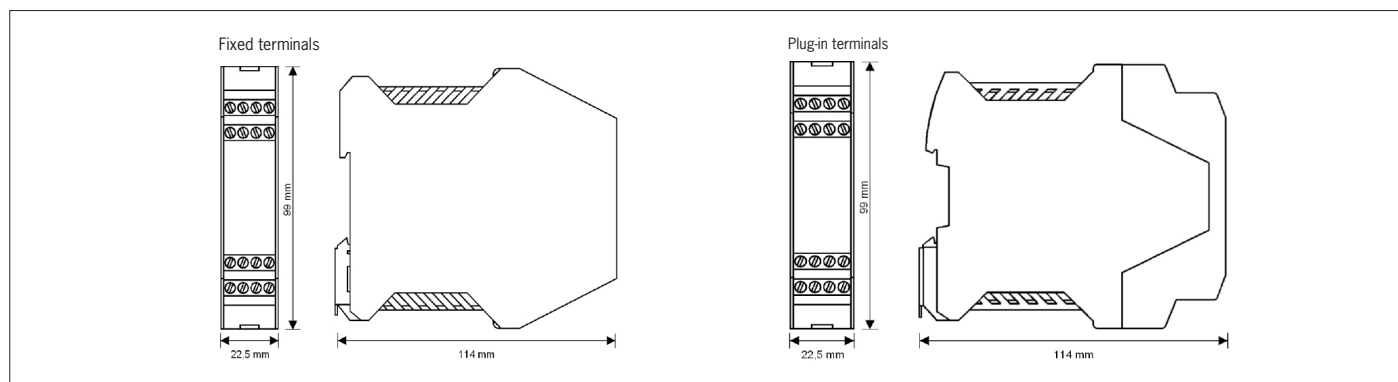

Fig. 4: Dimension drawing for ESM-2H2..

Application

The buttons in the two-hand circuit must be arranged and be such that accidental operation is prevented and the protective effect cannot be easily bypassed. Here the regulations in the applicable standards, in particular EN ISO 13851 and DIN EN ISO 13855, are to be observed. The ESM-2H2.. is intended for the connection of two-hand buttons each with one NC contact and one NO contact.

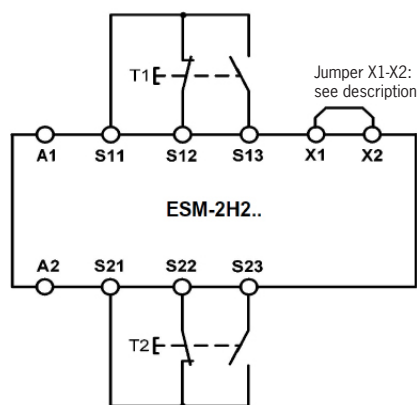

Fig. 5: Wiring for the ESM-2H2.. with two-hand buttons (NC/NO contact)

Feedback loop

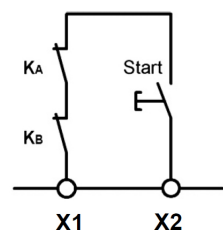

Fig. 6: If an external contactor or expansion module (e. g. ESM-ES3..) is to be connected to ESM-2H2.. to increase the rating of the contacts or the number of contacts, its positively driven monitoring contacts (NC contacts) are to be connected in series and connected to the connections for the feedback loop X1 and X2.

Power supply

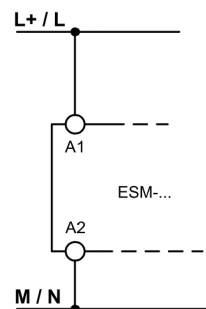

Fig. 7: Connection of the power supply to terminals A1 and A2 (power supply according to the technical data).

Subject to technical modifications; no responsibility is accepted for the accuracy of this information. © EUCHNER GmbH + Co. KG 21.09.07-07-08/22 V1.1.0 (translation of the original operating instructions)