

EUCHNER

Operating Instructions

BR/IO-Link Gateway

GWY-CB-1-BR-IO

EN

Contents

1.	About this document	4
1.1.	Scope.....	4
1.2.	Target group	4
1.3.	Key to symbols.....	4
1.4.	Supplementary documents	4
2.	Correct use	4
3.	Exclusion of liability and warranty	5
4.	General safety precautions	5
5.	Function	5
5.1.	IO-Link communication and functions	5
5.1.1.	Chain reset.....	5
5.2.	Communication and functions with BR/BP safety switches	5
5.2.1.	Diagnostic data.....	5
5.2.2.	Hot plugging – replacing a BR safety switch	6
6.	Mounting	6
7.	Electrical connection	7
7.1.	Terminal assignment	7
7.2.	Block diagram	8
7.3.	Notes about cULus	8
7.4.	Insulation coordination.....	8
8.	Application example	9
8.1.	Connecting the GWY-CB gateway to a BR switch chain.....	9
9.	Setup	10
10.	Device diagnostics	10
10.1.	Diagnostics via LED displays	10
10.1.1.	General states	10
10.1.2.	Error messages.....	11
11.	IO-Link communication and diagnostic data	12
11.1.	Device description file	12
11.1.1.	Overview of IODDs	12
11.1.2.	Use of the various IODDs.....	12
11.2.	Process-data structure and addressing.....	13
11.3.	Cyclical data (process data).....	14
11.3.1.	Input data.....	14
11.3.2.	General description of the process data	14
11.3.3.	Output data	15
11.4.	Acyclical data (device data and events).....	16
11.4.1.	Writing and reading services	16

11.5.	Communication with BR/BP devices	18
11.6.	Error table for BR/BP devices.....	19
12.	Technical data	21
12.1.	Gateway GWY-CB-1-BR-IO.....	21
13.	Ordering information and accessories	23
14.	Inspection and service	23
15.	Service	23
16.	Declaration of conformity	24

1. About this document

1.1. Scope





This document is valid for:

- › BR/IO-Link Gateway GWY-CB-1-BR-IO

1.2. Target group



Design engineers and installation planners for safety devices on machines, as well as setup and servicing staff possessing special expertise in handling safety components. These persons must also be familiar with the safety concept underlying this customer-specific solution.

1.3. Key to symbols

Symbol/depiction	Meaning
	Printed document
	Document is available for download at www.euchner.com
 DANGER WARNING CAUTION	Safety precautions Danger of death or severe injuries Warning about possible injuries Caution slight injuries possible
 NOTICE Important!	Notice about possible device damage Important information
Tip	Useful information

1.4. Supplementary documents

The overall documentation for this device consists of the following documents:

Document title (document number)	Contents	
Operating Instructions BR/IO-Link Gateway GWY-CB-1-BR-IO (2535803)	(this document)	
Possibly enclosed data sheet	Item-specific information about deviations or additions	



Important!

Always read all documents to gain a complete overview of safe installation, setup and use of the device. The documents can be downloaded from www.euchner.com. For this purpose enter the doc. no. in the search box.

2. Correct use

- › The gateway is used to implement the data of a BR switch chain or a BP switch on an IO-Link slave.





Important!

- › Correct use requires observing the permissible operating parameters (see chapter 12. *Technical data*).
- › Only components that are intended for combination with the device may be used. Also observe the operating instructions for the components used (see chapter 1.4. *Supplementary documents*)

3. Exclusion of liability and warranty

In case of failure to comply with the conditions for correct use stated above, or if the safety regulations are not followed, or if any servicing is not performed as required, liability will be excluded and the warranty void.

4. General safety precautions

	<p>WARNING</p> <ul style="list-style-type: none"> › Mounting, electrical connection and setup only by authorized personnel possessing the following knowledge: <ul style="list-style-type: none"> - specialist knowledge in handling safety components - knowledge about the applicable EMC regulations - knowledge about the applicable regulations on operational safety and accident prevention.
	<p>Important!</p> <p>Prior to use, read the operating instructions and keep these in a safe place. Ensure the operating instructions are always available during mounting, setup and servicing. For this reason you should archive a printed copy of the operating instructions. You can download the operating instructions from www.euchner.com.</p>

5. Function

5.1. IO-Link communication and functions

The gateway is an IO-Link device.

Communication via IO-Link offers cyclical (process data) and acyclical (device data and events) data exchange.

	<p>Important!</p> <p>The cyclical and acyclical data can be found in chapter 11. <i>IO-Link communication and diagnostic data</i>.</p>
---	---

The following information is transmitted:

- › Device information of the gateway (electronic rating plate, states of the device)
- › State information about connected BR/BP safety switches

IO-Link communication can be used for the following functions as well:

- › Chain reset: performing a reset of the BR safety switch chain

5.1.1. Chain reset

All BR safety switches in a chain or individual BP safety switches can be centrally restarted with a chain reset via IO-Link communication.

This function enables simple acknowledgment after troubleshooting.

The chain reset command is controlled via cyclical data exchange (process data).

5.2. Communication and functions with BR/BP safety switches

5.2.1. Diagnostic data

The ID/C connection of the gateway allows the diagnostic line of a BR safety switch chain or of a BP safety switch to be connected.

The ID/C connection represents a non-safety-related communication channel between the gateway and the safety switches.

The switches address the individual switches when the safety switch chain starts up. Addressing permits unique diagnostics for each safety switch.

The gateway synchronizes itself with the safety switch chain or with the safety switch after a restart. The safety switches are then available for communication and diagnostics. The safety outputs of the connected switch chain/switch can be enabled only after complete BR/BP communication has been established.

5.2.2. Hot plugging – replacing a BR safety switch

A safety switch within a BR safety switch chain can be replaced during operation. This process is called *hot plugging*. In order to perform correct addressing after replacement, only one safety switch can be replaced at a time (1:1 replacement). If another safety switch is to be replaced, the required switch-on delay of the previously replaced switch must be taken into account.



Important!

Observe the technical data of the BR safety switch in the corresponding product documentation.

6. Mounting



NOTICE

Device damage due to improper installation or unsuitable ambient conditions.

- › The gateway must be installed in a control cabinet protected against dust and moisture, with a minimum degree of protection of IP54. A snap-in element on the rear of the device is used for fastening to a mounting rail.
- › When mounting several gateways side by side in a control cabinet without air circulation (e.g. fan), note that a minimum distance of 10 mm must be maintained between the evaluation units. This distance enables the heat from the evaluation unit to dissipate.

- › Mount the device on a 35-mm mounting rail according to EN 60715.
- › Loosen the locking foot using a screwdriver to remove.

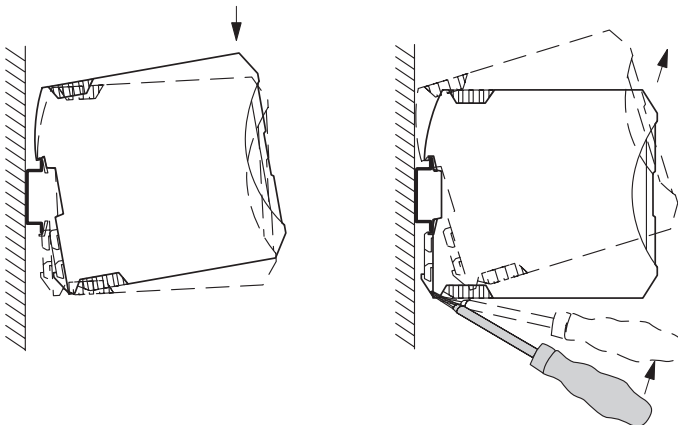

Figure 1: Mounting and removing

7. Electrical connection



NOTICE

- Risk of damage to equipment or malfunctions as a result of incorrect connection.
- › All the electrical connections must either be isolated from the mains supply by a safety transformer according to IEC 61558-2-6 with limited output voltage in the event of a fault, or by other equivalent isolation measures.
 - › Protect the 24 V area with a suitable external fuse.
 - › Make sure that the power supply unit can provide quadruple the nominal current of the external fuse in order to guarantee reliable triggering in case of a fault.

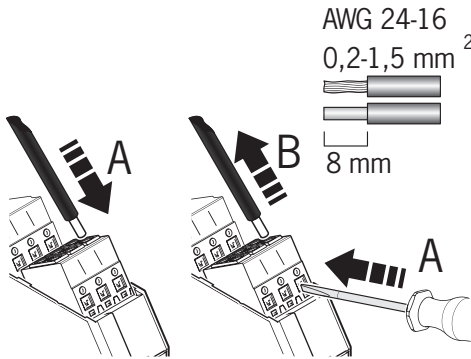

Figure 2: Cable connection (spring terminal)



Tip!

- › It is recommended to use cable end sleeves for connecting flexible cables.

7.1. Terminal assignment

ID/C	
24 V	GND
<input type="checkbox"/>	BR/FC
<input type="checkbox"/>	DIA
<input type="checkbox"/>	IO-Link
IO-Link EUCHNER GWY-CB	
L+	L-
C/Q	

24 V	Power supply 24 V DC
GND	Power supply 0 V
DIA	Diagnostic message present indication; LED (red)
IO-Link	IO-Link communication status indication; LED (green)
BR/FC	Indication of BR chain and error codes; LED (green)
ID/C	Diagnostic input for safety switches with BP/BR technology
C/Q	IO-Link switching and communication line
L+/L-	Power supply from IO-Link master

7.2. Block diagram

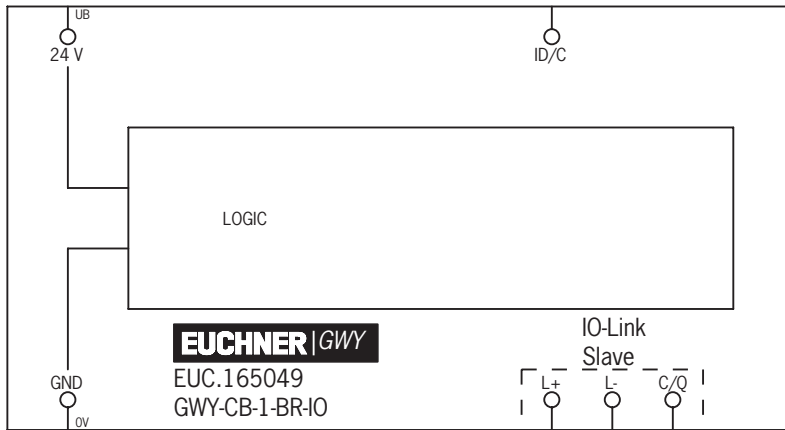

Figure 3: Block diagram

24 V	Power supply 24 V DC
GND	Power supply 0 V
ID/C	Diagnostic input for safety switches with BP/BR technology
L+/L-	Power supply from IO-Link master
C/Q	IO-Link switching and communication line

7.3. Notes about

	<p>Important!</p> <ul style="list-style-type: none"> ▶ This device is intended to be used with a <i>Class 2</i> power source in accordance with UL1310. As an alternative an LV/C (Limited Voltage/Current) power source with the following properties can be used: <ul style="list-style-type: none"> - This device shall be used with a suitable isolating source in conjunction with a fuse in accordance with UL248. The fuse shall be rated max. 3.3 A and be installed in the max. 30 V DC power supply to the device in order to limit the available current to comply with the UL requirements. Please note possibly lower connection ratings for your device (refer to the technical data). ▶ Use cable material made of copper with a temperature resistance of 60° C/75 °C. <p><small>1) Note on the scope of the UL approval: the devices have been tested as per the requirements of UL508 and CSA/ C22.2 no. 14 (protection against electric shock and fire).</small></p>
--	--

7.4. Insulation coordination

	<p>WARNING</p> <p>Loss of electrical safety</p> <ul style="list-style-type: none"> ▶ Take measures outside the device to limit transient overvoltages to the respective value for over-voltage category II.
--	---

	24 V/GND, logic	IO-Link	Housing
24 V/GND, logic	-	0.5 kV ST	4 kV BI
IO-Link	-	-	4 kV BI

Key:
BI Basic insulation
ST Safe isolation
Logic Sensor and start circuits, monitoring output, diagnostic input
IO-Link IO-Link supply, IO-Link switching and communication line

8. Application example

8.1. Connecting the GWY-CB gateway to a BR switch chain

- IO-Link connection of a BR switch chain

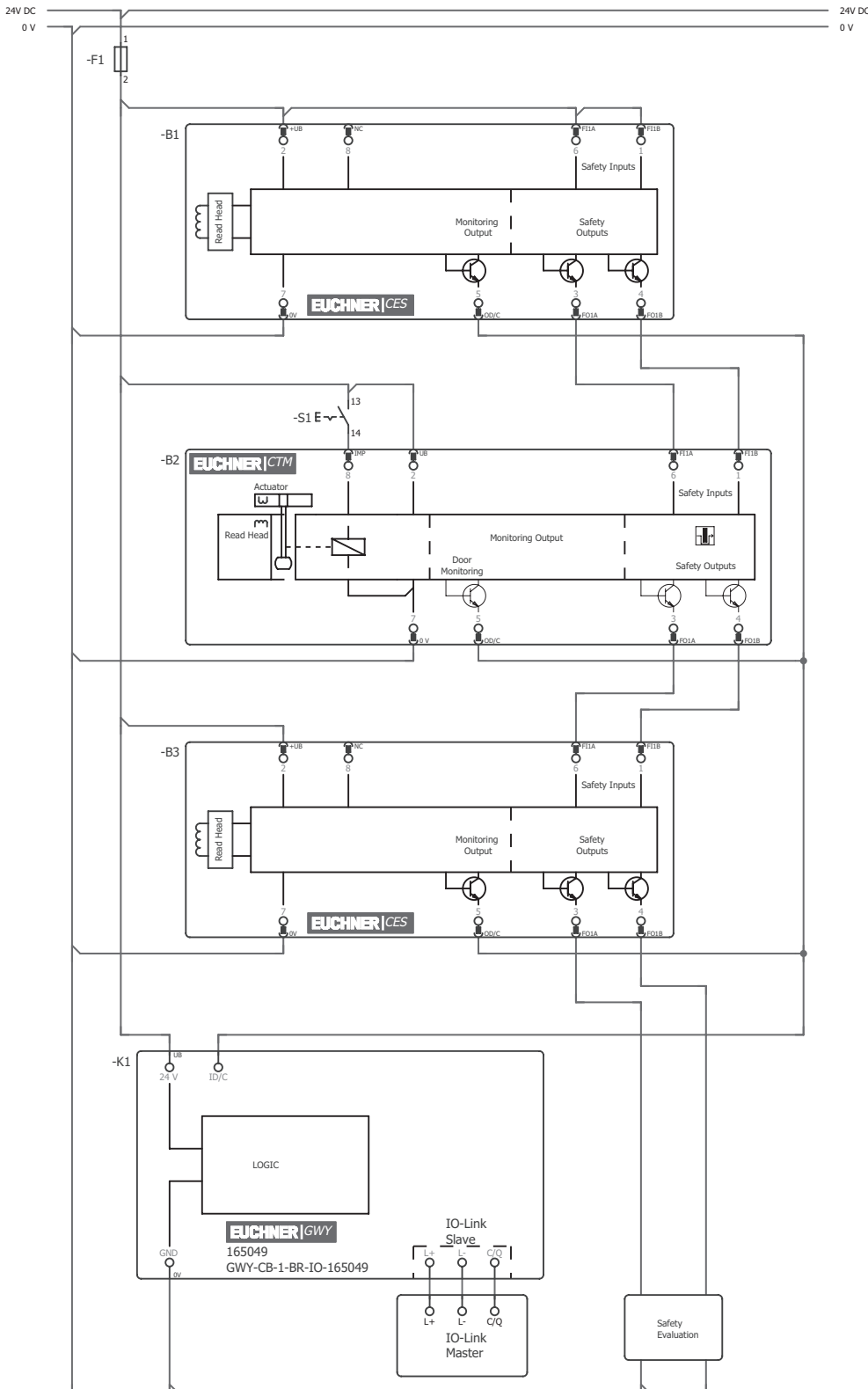

Figure 4: Basic circuit diagram

Key:
B1 ... B3 BR safety switch
F1 External fuse

9. Setup

Integrating the device description file

- › Integrate the suitable device description file (IODD) into the engineering tool in accordance with the number of connected BR safety switches (see chapter 11.1. *Device description file*).
- › Download the configuration to the IO-Link master.

Setting up the gateway

- › Connect the IO-Link supply L+/L- and the switching and communication cable C/Q to the corresponding port of the IO-Link master.
- › Connect the power supply (24 V DC / 0 V) to terminals 24 V/GND.
- ➔ The BR/FC LED illuminates green.
- ➔ The IO-Link LED flashes green once IO-Link communication has been established.

Possible diagnoses

The status information of the individual BR safety switches and the device information of the gateway can be processed by the cyclical data (see chapter 11.3. *Cyclical data (process data)*).

10. Device diagnostics

10.1. Diagnostics via LED displays



Important!

Behavior of the IO-Link LED

- › In the operating state with IO-Link, the IO-Link LED flashes green while IO-Link communication is active.
- › If the IO-Link LED is switched off in the operating state with IO-Link, this indicates a loss of communication. Check the IO-Link connection in this case.

















10.1.1. General states

No.	Status	LEDs			State
		DIA red	BR/FC green	IO-Link green	
1	PowerUp	○	☀ 5 Hz	○	
2	Ready	○	☀	X	



Key:

○	LED off
☀	LED illuminated
☀ 5 Hz	LED flashes at 5 Hz
X	State-dependent

10.1.2. Error messages

No.	Fault	LEDs			State
		DIA red	BR/FC green	IO-Link green	
3	Internal error				
4	Low voltage L+			 5x	
5	Low voltage 24 V DC		 5x		
6	BR communication error			X	
7	BR communication error on one device			X	
8	Parameter error		 3x		

Key:

	LED off
	LED illuminated
 3x	LED flashes three times
	Flash burst
X	State-dependent

11. IO-Link communication and diagnostic data

11.1. Device description file

Depending on the number of connected BR safety switches, you will require a corresponding device description file (IO-Link Device Description, IODD).

You can use the device description file to configure and set up IO-Link devices. It contains information about identification, device parameters, process and diagnostic data, communication properties and the design of the user interface in engineering tools.

The valid device description files are available for download from the address www.euchner.com|service|download|software.

You additionally have the option of downloading the device description file from the official IO-Link page ioddfinder.io-link.com. Go to the *IODDfinder*.



Important!

If you selected an incorrect IODD or an IODD that offers too few inputs or outputs for your system design, your IO-Link configuration software will display a corresponding error message.

11.1.1. Overview of IODDs

Vendor ID		Device ID		Inputs	Outputs
hex	dec	hex	dec		
135	309	020101	131329	6	1
135	309	020102	131330	11	1
135	309	020103	131331	21	1
135	309	020104	131332	11	6
135	309	020105	131333	21	11
135	309	020106	131334	31	16

11.1.2. Use of the various IODDs

Different IODDs can be used depending on the length of a series connection. They differ in the number of process-data items on the input side and output side.

No outputs are required for series connections of interlocks, such as the CES-C07. Use the IODD that is the most suitable for the length of your chain.

Example: When connecting seven CES-C07 in series, use the IODD *Euchner-GWY_CB_165049_11x1-20200122-IODD1.1* for up to ten CES-C07 plus one byte for the evaluation unit. 8 bytes are used on the input side in this case.

Outputs are additionally required in the process data for series connections of guard locking devices, e.g. CTM. Additionally, guard locking devices each send 2 bytes in the input data. Here, it is recommended to use the following IODD for a chain of 3 CTM devices, for example: *Euchner-GWY_CB_165049_11x6-20200122-IODD1.1*. 7 bytes are used on the input side and 4 bytes on the output side in this case.

For mixed series connections consisting of guard locking devices and interlocking devices, use the following formulas to calculate the value of the input data:

$$n_{\text{Input}} = \text{Quantity}_{\text{Interlocking device}} + 2 \times \text{Quantity}_{\text{Guard locking device}} + 1$$

$$n_{\text{Output}} = \text{Quantity}_{\text{Guard locking device}} + 1$$

11.2. Process-data structure and addressing

Refer to the following illustration and the associated table for the structure of the process data and for the addressing of a BR safety switch chain.

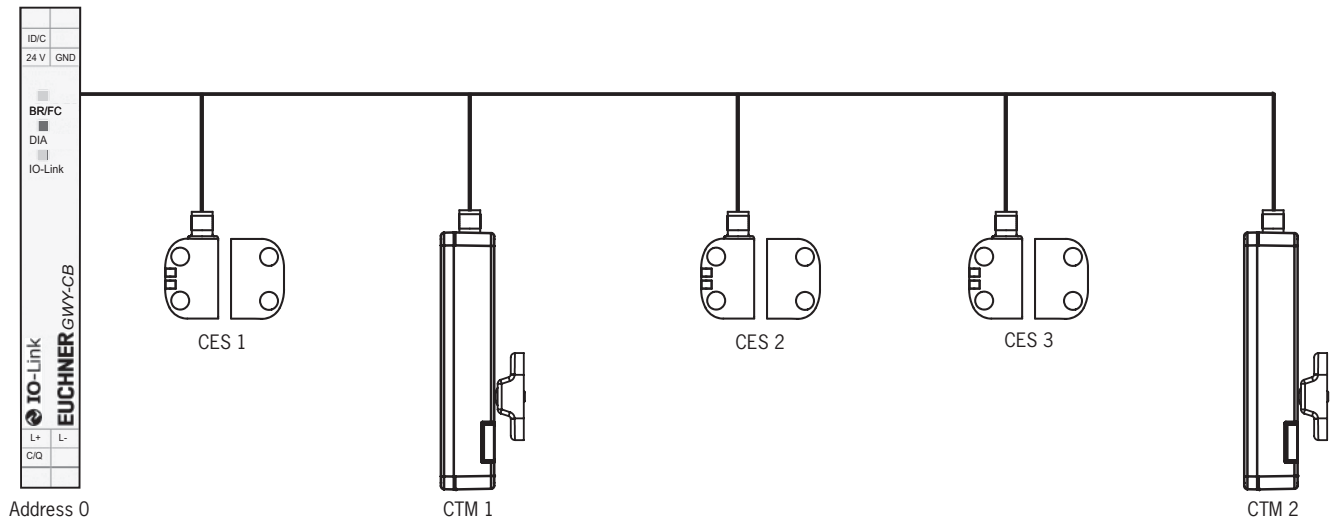

Figure 5: Addressing

Example: CES-CTM-CES-CES-CTM

IODD *Euchner-GWY_CB_165049_11x6-201200122-IODD1.1* is used

Byte	0	1	2	3	4	5	6	7	8	9	10
Input I	GWY-CB IO	CTM2 IO	CTM2 I1	CES3 IO	CES2 IO	CTM1 IO	CTM1 I1	CTM1 IO	CES1 IO	-	-
Output O	GWY-CB O1	CTM1 O0	CTM2 O0								

11.3. Cyclical data (process data)

Depending on the corresponding IODD, the device occupies 6/11/21/31 bytes of input process data and 1/6/11/16 bytes of output data.

11.3.1. Input data

Byte 0 (IO-Link diagnostic bits/status of GWY-CB)

Bit	Description	Value
Bit 4 ... bit 7	Error messages	See device status and error messages

Device status and error messages

	<p>Important!</p> <ul style="list-style-type: none"> ▸ If several error codes are active simultaneously, the error code with the highest priority will displace the other active error codes. ▸ Error code 0000 <i>Ongoing operation</i> is permanently active.
---	--

Bit 4 ... bit 7	Description	Possible cause	Remedy
0111	System error	Internal error	Perform a power-down reset followed by a function test. Replace the device if the error recurs after the function test.
0101	IO-Link low voltage		Check the power supply.
0100	GWY-CB low voltage		Check the power supply.
0011	Diagnostic communication error	One or more safety switches cannot be reached.	Restart the safety switch chain.
0010	Parameter error	Wrong manufacturer's code of a switch. Permanently configured process-data size insufficient.	Use only suitable BR/BP safety switches. Remove the permanent configuration of the process-data size.
0001	Diagnostics active	Internal error	Perform a power-down reset followed by a function test. Replace the device if the error recurs after the function test.
0000	Ongoing operation	-	-

11.3.2. General description of the process data

Byte	Bit 7	Bit 6	Bit 5	Bit 4	Bit 3	Bit 2	Bit 1	Bit 0
Input byte I-0	OI	-	-	OR	OM	-	OW	OD
Input byte I-1	-	-	-	-	-	-	OL	OT

OI General error message

Retrieve the exact error code via an acyclical service.

OR State of the switch's predecessor

Indicates whether the preceding switch in the series connection has switched on the safety outputs.

OM State of the safety outputs of the switch

Indicates whether the switch has switched on the safety outputs.

OW Actuator weak area

When this bit is set, the actuator is at the edge of the detection area.

OD Door position

The bit is set when the guard is closed (it does not have to be locked).

OL Guard locking

The bit is set when guard locking is activated.

OT Bolt/actuator

The bit is set when a bolt/actuator has been detected.

Please refer to the manual of the connected interlocking device or guard locking device to determine which bits are actually used. Not all switches support every bit.

11.3.3. Output data

Byte 0 (IO-Link diagnostic bits/status of GWY-CB)

Bit	Description	Value
1	Chain reset	A chain reset is performed at the transition from 1 to 0
2 ... 7	Reserved	

11.4. Acyclical data (device data and events)

11.4.1. Writing and reading services



Important!

The manufacturer's code for EUCHNER is 0x01.

Index 100 – reading service: size of the input/output data areas

Index dec (hex)	Subindex dec (hex)	No.	Type	Description	
100 (64)	0 (0)	1 (1)	1	UInt8	Manufacturer's code, safety switch 1
			2	UInt8	Size of input process data, safety switch 1
			3	UInt8	Size of output process data, safety switch 1
		2 (2)	4	UInt8	Manufacturer's code, safety switch 2
			5	UInt8	Size of input process data, safety switch 2
			6	UInt8	Size of output process data, safety switch 2
	UInt8	...	
	31 (1F)	91	UInt8	Number of safety switches	

Index 101 – reading service: manufacturer's codes of the devices

Index dec (hex)	Subindex dec (hex)	No.	Type	Description	
101 (65)	0 (0)	1 (1)	1	UInt8	Manufacturer's code, safety switch 1
		2 (2)	2	UInt8	Manufacturer's code, safety switch 2
		UInt8	...
		30 (1E)	30	UInt8	Manufacturer's code, safety switch 30
		31 (1F)	31	UInt8	Number of safety switches

Index 102 – reading service: size of the input data area

Index dec (hex)	Subindex dec (hex)	No.	Type	Description	
102 (66)	0 (0)	1 (1)	1	UInt8	Size of input process data, safety switch 1
		2 (2)	2	UInt8	Size of input process data, safety switch 2
		UInt8	...
		30 (1E)	30	UInt8	Size of input process data, safety switch 30
		31 (1F)	31	UInt8	Number of safety switches

Index 103 – reading service: size of the output data area

Index dec (hex)	Subindex dec (hex)	No.	Type	Description	
103 (67)	0 (0)	1 (1)	1	UInt8	Size of output process data, safety switch 1
		2 (2)	2	UInt8	Size of output process data, safety switch 2
		UInt8	...
		30 (1E)	30	UInt8	Size of output process data, safety switch 30
		31 (1F)	31	UInt8	Number of safety switches

Index 201 ... 230 – writing service: command to individual switch



NOTICE

The possible telegrams are described in chapter 11.5. *Communication with BR/BP devices.*

Index dec (hex)	Subindex dec (hex)	No.	Type	Description
201 (C9)	0 (0)	1	UInt8	User data length for the telegram for safety switch 1
		2 ... 8	UInt8	User data for the telegram for safety switch 1
202 (CA)	0 (0)	1	UInt8	User data length for the telegram for safety switch 2
		2 ... 8	UInt8	User data for the telegram for safety switch 2
...
230 (E6)	0 (0)	1	UInt8	User data length for the telegram for safety switch 30
		2 ... 8	UInt8	User data for the telegram for safety switch 30

The telegram consists of 8 bytes for writing to the indices. The user data in the telegram must therefore be padded with 00.

Example:

01 02 00 00 00 00 00 00

01 = User data length

02 = Request telegram to the GWY-CB (order number/serial number)

Bytes 2 ... 7: padded zeros

Index 250 – writing service: IO-Link mode

Index dec (hex)	Subindex dec (hex)	No.	Type	Description
250 (FA)	0 (0)	1	UInt8	Reset of IO-Link mode 0x01 : reset IO-Link mode 0xFF : retain IO-Link mode

Index 10 ... 17 – reading service: retrieving the data of the GWY-CB

Index dec (hex)	Subindex dec (hex)	No.	Type	Description
16 (10)	0 (0)	-	String	Manufacturer
17 (11)	0 (0)	-	String	Manufacturer's text
18 (12)	0 (0)	-	String	Product name
19 (13)	0 (0)	-	String	Product ID
20 (14)	0 (0)	-	String	Product text
21 (15)	0 (0)	-	String	Serial number
22 (16)	0 (0)	-	String	Hardware version
23 (17)	0 (0)	-	String	Firmware version

11.5. Communication with BR/BP devices

Notice: The data are in big-endian format.

Transmission			Reply	
Hex	Dec	Command	Number of bytes	Number of bytes
2	2	Send order no. and serial no.	3 bytes for order no.	3 bytes for serial no.
3	3	Send device version	1 byte for letter V	4 bytes for version number, e.g. 1.0.1.0 (the periods are not transmitted)
5	5	Send number of safety switches in the series connection	2 bytes	
10	16	Send number of switching operations (bolt tongue)	3 bytes for counter value	
11	17	Send number of switching operations (solenoid)	3 bytes for counter value	
12	18	Send current error code	1 byte for error code	
13	19	Send saved error code (history)	1 byte for error code. This error is no longer present.	
14	20	Send size of log file	1 byte for length of the current log file	
15	21	Send entry from log file with index. The required index must be sent in the second byte.	1 byte for error code	
16	22	Send current actuator code	5 bytes for code of the currently read actuator	
17	23	Send taught-in actuator code	With unicode evaluation: 5 bytes for code of the taught-in actuator in the switch With multicode evaluation: replies with 5x 0xFF	
18	24	Send disabled actuator code	With unicode evaluation: 5 bytes for code of the currently disabled actuator With multicode evaluation: replies with 5x 0xFF	
19	25	Send applied voltage	2 bytes for voltage value in mV	
1A	26	Send current temperature	1 byte for temperature value in °C	
1B	27	Send number of switching cycles	3 bytes for counter value	
1D	29	Reset device	1 byte for acknowledgment, value hex 1D	
1E	30	Factory-reset device	1 byte for acknowledgment, value hex 1E	



NOTICE

Refer to the operating instructions of the respective BR/BP safety switch used for information about the supported commands. Not all commands are used by every switch.

11.6. Error table for BR/BP devices

Depending on the device type, not all error messages are required or supported.

Error number	Error designation	Cause	Rectification
General errors			
0x01	Internal error	All errors that prevent normal operation and over which the customer has no control. Errors in the program data Errors in the internal electronics Safe control of guard locking no longer possible	Restart the device. If the fault still exists, the device must be returned unopened to the manufacturer.
0x06	Internal error	Fault on the internal switching element. Guard locking can no longer be controlled safely.	
Teach-in errors			
0x1F	Actuator removed during teach-in operation.	- The actuator was removed before the teach-in operation was completed. - The actuator left the actuating range during the teach-in operation.	Repeat the teach-in operation. Ensure that the actuator is in the actuating range during the entire teach-in operation. If the fault still exists, the actuator might be defective.
0x20	DIP switch configuration does not correspond to the software configuration.	DIP switch configuration is not identical to the configuration saved in the memory.	Check the DIP switch configuration or change the configuration of the switch. Teach-in the changed DIP switch configuration again. Restart the connected safety switch.
0x21 / 0x24	DIP switch configuration between the channels not plausible.	DIP switch configuration for the two channels is not plausible or does not match.	Adapt and teach-in the DIP switch configuration. Restart the connected safety switch.
0x23	DIP switch configuration was changed during operation.	See error designation	Check the DIP switch configuration or change the configuration of the switch. Teach-in the changed DIP switch configuration again. Restart the connected safety switch.
0x25	Disabled actuator detected during teach-in operation.	See error designation	Repeat the teach-in operation with a new actuator.
Input errors			
0x2E	Different states of F11A and F11B.	Different signal states at the two safety inputs.	Check the wiring and the preceding device in the switch chain.
0x2F	Communication error BR (master)	Diagnostics communication between master and slave not possible/communication disrupted.	Check the wiring and the status of the master. Check whether the correct Y-distributor is used. Check the cable length
0x30	Different states of F11A and F11B during power-up.	Different signal states at the two safety inputs.	Check the wiring and the preceding device in the switch chain.
0x31	Test pulse on F11A not detected.	Missing test pulse, e.g. short circuit, F11A and F11B interchanged.	Check the wiring and the preceding device in the switch chain.
0x32	Test pulse on F11B not detected.	Missing test pulse, e.g. short circuit, F11A and F11B interchanged.	Check the wiring and the preceding device in the switch chain.
0x34	Start button error	- Start button was pressed for too long - Start button is stuck or fused	- Press the start button for a shorter time - Check the function of the start button
0x35	Start button strapping plug	The strapping plug for the start button was removed	Check the wiring of the start button and acknowledge the error Restart the device if necessary
0x36	Test pulse on F11A not detected on PowerUp.	Missing test pulse	Check the wiring and the preceding device in the switch chain.
0x37	Test pulse on F11B not detected on PowerUp.	Missing test pulse	Check the wiring and the preceding device in the switch chain.
Transponder errors			
0x42	Invalid actuator detected during teach-in operation.	Actuator detected is not a valid actuator or actuator is faulty	Repeat the teach-in operation with a new, valid actuator.
0x44	Invalid actuator detected	Actuator detected is not a valid actuator or actuator is faulty	- Remove the actuator from the actuating range - Use a new, valid actuator
Output error			
0x4C, 4x4D, 0x54	Output error	The level at the safety output does not match the expected level; external voltage might be present.	Check the wiring

Error number	Error designation	Cause	Rectification
Environment errors			
0x60	Supply voltage too high.	Overvoltage	Reduce the supply voltage
0x61	Supply voltage too low.	Low voltage	Increase the supply voltage or check the system topology (cable lengths and number of safety switches in the switch chain)
0x62	Temperature too high.	Temperature in housing too high.	Device is operated in an impermissible temperature range
0x63	Temperature too low.	Temperature in housing too low.	
0x64	Guard locking supply voltage too high.	Overvoltage	Reduce the supply voltage and restart the device
0x65	Guard locking supply voltage too low.	Low voltage	Increase the supply voltage or check the system topology (cable lengths and number of safety switches in the switch chain)
0x67	Advance warning: supply voltage too low 5%.	Low voltage	Increase the supply voltage or check the system topology (cable lengths and number of safety switches in the switch chain)
Plausibility errors			
0x88	Plausibility error: bolt fracture	Transponder for the bolt/actuator has been detected without the door closed.	Check for a broken bolt/actuator; acknowledge the error
0x89	Actuator broken	Transponder is no longer detected while guard locking is active.	Check the actuator and replace it if necessary. If necessary, the switch must be replaced as well.
0x8A	Plausibility error: signal sequence	Transponder has been detected without movement of the locking arm (latch). This could happen if the door is closed too quickly.	Open the door, acknowledge the error and close the door more slowly. If the fault still exists, the device must be returned unopened to the manufacturer.
0x8B	Escape release	Escape release has been actuated (only if parametrized).	Acknowledge the error
0x8C	Plausibility error: auxiliary release	Auxiliary release has been actuated, or internal error	Open the door and then close it again. If guard locking can no longer be activated, the device must be returned unopened to the manufacturer.

12. Technical data



NOTICE

If a data sheet is included with the product, the information on the data sheet applies.

12.1. Gateway GWY-CB-1-BR-IO

- › Diagnostic data via IO-Link in combination with BR/BP devices
- › Plug-in spring terminals
- › 12.5 mm housing width

Approvals



Dimension drawing

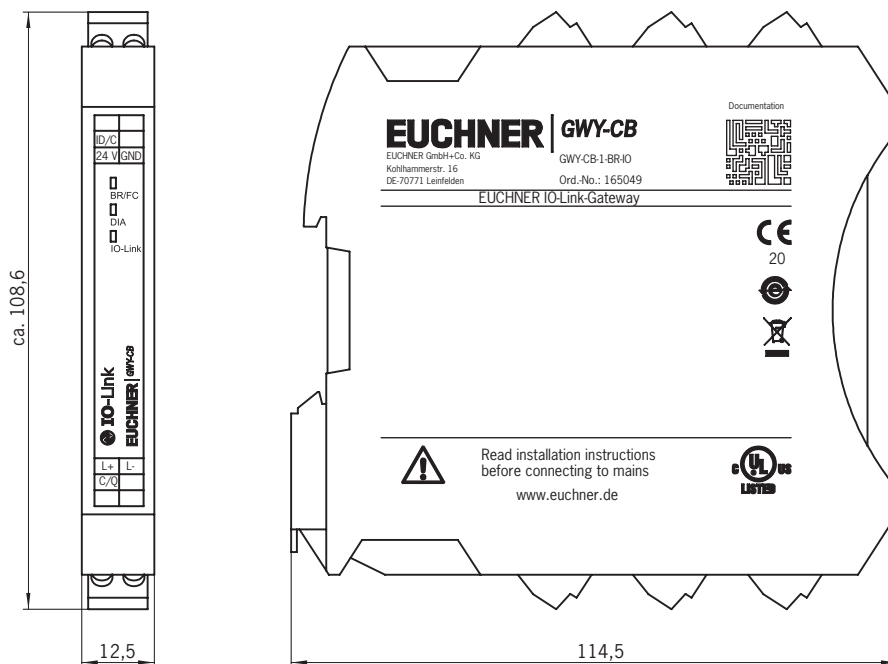

Technical data for GWY-CB-1-BR-IO

Hardware/firmware version	
HW/FW	≥ 00/100
The technical data and the safety characteristics are valid from the specified HW/FW version.	
Supply	
Name	24 V/GND
Operating voltage U_S	24 V DC -20% / +25% (fuse externally)
Rated control supply current I_S	Typ. 60 mA
Power consumption at U_S	Typ. 1.44 W
Switch-on current	Typ. 2.5 A ($\Delta t = 500 \mu s$ at U_S)
Filter time	1 ms (at 24 V in case of voltage dips at U_S)
Suppressor circuit	Serial reverse polarity protection
IO-Link ports: class A	
Number of ports	1
Connection	Spring terminals
Connection technology	3-conductor
Specification	Version 1.1
Transmission rate	230 kbit/s (COM3)
Cycle time	5 ms
Process-data update	5 ms
Number of process-data items	Max. 31 bytes (input data) Max. 16 bytes (output data)
IO-Link port supply: L+/L-	
Rated periphery supply voltage	24 V DC -20% / +25% (provided via the IO-Link interface of the IO-Link master)
Current consumption	Typ. 16 mA
Suppressor circuit	Serial reverse polarity protection
IO-Link switching and communication line: C/Q	
Number of inputs	1
General data	
Degree of protection	IP20
Minimum degree of protection of installation location	IP54
Mounting method	Rail mounting
Installation orientation	Vertical or horizontal
Housing version	PBT, gray
Rated insulation voltage	30 V
Rated impulse withstand voltage/insulation See chapter <i>Insulation coordination</i>	Basic insulation of 4 kV between all current paths and the housing.
Degree of contamination	2
Overvoltage category	II
Dimensions	
	Housing
W x H x D	12.5 x 108.6 x 114.5 mm
Connection data	
	Spring terminals
Conductor cross-section, rigid	0.2 mm ² ... 1.5 mm ²
Conductor cross-section, flexible	0.2 mm ² ... 1.5 mm ²
Conductor cross-section, AWG/kcmil	24 ... 16
Stripping length	8 mm
Ambient conditions	
Ambient temperature (operation)	-25 °C ... 60 °C
Ambient temperature (storage/transport)	-40 °C ... 85 °C
Max. perm. atmospheric humidity (operation)	75% (on average, 85% occasionally, no dew formation)
Max. perm. atmospheric humidity (storage/transport)	75% (on average, 85% occasionally, no dew formation)
Shock	15 g
Vibration (operation)	10 Hz ... 150 Hz, 2 g

13. Ordering information and accessories



Tip!

Suitable accessories, e.g. cables or assembly material, can be found at www.euchner.com. To order, enter the order number of your item in the search box and open the item view. Accessories that can be combined with the item are listed in *Accessories*.

14. Inspection and service



WARNING

- › In case of damage, the entire device must be replaced.
- › Only accessories or spare parts that can be ordered from EUCHNER may be replaced.

Regular inspection of the following is necessary to ensure trouble-free long-term operation:

- › Check the secure mounting of the devices and the connections
- › Check for soiling

No servicing is required. Repairs to the device are only allowed to be made by the manufacturer.



NOTICE

The year of manufacture can be seen on the rating plate below the CE marking. The current version number in the format HW/FW: xx/xxx can also be found on the device.

15. Service

If servicing is required, please contact:

EUCHNER GmbH + Co. KG
Kohlhammerstraße 16
70771 Leinfelden-Echterdingen
Germany

Service telephone:
+49 711 7597-500

E-mail:
support@euchner.de

Internet:
www.euchner.com

16. Declaration of conformity



EUCHNER

More than safety.

EU-Konformitätserklärung
EU declaration of conformity
Déclaration UE de conformité
Dichiarazione di conformità UE
Declaración UE de conformidad

Original DE
Translation FR
Traduction EN
Traduzione IT
Traducción ES

2535665-02-07/20

Die nachfolgend aufgeführten Produkte sind konform mit den Anforderungen der folgenden Richtlinien (falls zutreffend):
The beneath listed products are in conformity with the requirements of the following directives (if applicable):
Les produits mentionnés ci-dessous sont conformes aux exigences imposées par les directives suivantes (si valable)
I prodotti sotto elencati sono conformi alle direttive sotto riportate (dove applicabili):
Los productos listados a continuación son conforme a los requisitos de las siguientes directivas (si fueran aplicables):

I:	Maschinenrichtlinie Machinery directive Directive Machines Direttiva Macchine Directiva de máquinas	2006/42/EG 2006/42/EC 2006/42/CE 2006/42/CE 2006/42/CE
II:	EMV Richtlinie EMC Directive Directive de CEM Direttiva EMV Directiva CEM	2014/30/EU 2014/30/EU 2014/30/UE 2014/30/UE 2014/30/UE
III:	RoHS Richtlinie RoHS directive Directive de RoHS Direttiva RoHS Directiva RoHS	2011/65/EU 2011/65/EU 2011/65/UE 2011/65/UE 2011/65/UE

Folgende Normen sind angewandt:
Following standards are used:
Les normes suivantes sont appliquées:
Vengono applicate le seguenti norme:
Se utilizan los siguientes estándares:

a: EN ISO 13849-1:2015
b: EN 62061:2005+AC:2010+A1:2013+A2:2015
c: EN 61000-6-4:2007+A1:2011
d: EN 61326-1:2013
e: EN 50581:2012 (RoHS)
f: EN 61000-6-3:2007+A1:2011+AC:2012

Bezeichnung der Bauteile Description of components Description des composants Descrizione dei componenti Descripción de componentes	Type Type Tipo Tipo	Richtlinie Directives Directive Direttiva Directivas	Normen Standards Normes Norme Estándares	Zertifikats-Nr. No. of certificate Numéro du certificat Numero del certificato Número del certificado
Sicherheitsrelais Safety Relay Relais de sécurité Relais di sicurezza Relé de seguridad	ESM-CB...	I, II, III	a, b, c, d, e	01/205/5698.00/19
Gateway Gateway Gateway Gateway Gateway	GWY-CB...	II, III	e, f	

Benannte Stelle
Notified Body
Organisme notifié
Sede indicata
Entidad citada

NB 0035
TÜV Rheinland Industrie Service GmbH
Albainstrasse 56
12103 Berlin
Germany

Die alleinige Verantwortung für die Ausstellung dieser Konformitätserklärung trägt der Hersteller:
This declaration of conformity is issued under the sole responsibility of the manufacturer:
La présente déclaration de conformité est établie sous la seule responsabilité du fabricant:
La presente dichiarazione di conformità è rilasciata sotto la responsabilità esclusiva del fabbricante:
La presente declaración de conformidad se expide bajo la exclusiva responsabilidad del fabricante:

EUCHNER GmbH + Co. KG
Kohlhammerstraße 16
70771 Leinfelden-Echterdingen
Germany

Leinfelden Juli 2020

EUCHNER GmbH + Co. KG
Kohlhammerstraße 16
70771 Leinfelden-Echterdingen
Germany

i.A. Dipl.-Ing. Richard Holz
Leiter Elektronik-Entwicklung
Manager Electronic Development
Responsable Développement Électronique
Direttore Sviluppo Elettronica
Director de desarrollo electrónico

i.A. Dipl.-Ing. (FH) Duc Binh Nguyen
Dokumentationsbevollmächtigter
Documentation manager
Responsable documentation
Responsabilità della documentazione
Agente documenta

EUCHNER GmbH + Co. KG
Kohlhammerstraße 16
70771 Leinfelden-Echterdingen
Germany
info@euchner.de
www.euchner.com

Edition:
2535803-01-09/20
Title:
Operating Instructions BR/IO-Link Gateway GWY-CB-1-BR-IO
(Translation of the original operating instructions)
Copyright:
© EUCHNER GmbH + Co. KG, 09/2020

Subject to technical modifications; no responsibility is accepted for the accuracy of this information.