

# EUCHNER

## Operating Instructions

## Contents

<b>1.</b>	<b>About this document</b> .....	<b>5</b>
1.1.	Scope.....	5
1.1.1.	Notes on other product versions .....	5
1.2.	Target group .....	5
1.3.	Key to symbols.....	5
1.4.	Supplementary documents .....	5
<b>2.</b>	<b>Correct use</b> .....	<b>6</b>
<b>3.</b>	<b>Description of the safety function</b> .....	<b>7</b>
3.1.	Safety functions in combination with an interlocking or locking module MGB2-I or MGB2-L.....	7
3.2.	Safety functions on submodules with emergency stop .....	8
3.3.	Safety functions on submodules with enabling switch .....	9
3.4.	Safety functions on submodules with safe pushbuttons and switches (general) .....	9
3.5.	Safety functions on submodules without B <sub>10D</sub> (e.g. MSM-CKS2).....	10
3.6.	Safety functions on submodules with connection for OSSD safety switches.....	10
3.7.	Determining safety characteristics of the overall system.....	11
3.7.1.	Calculation example for the “monitoring of guard locking” safety function .....	11
3.7.2.	Calculation example for the “emergency stop” safety function .....	11
<b>4.</b>	<b>Exclusion of liability and warranty</b> .....	<b>12</b>
<b>5.</b>	<b>General safety precautions</b> .....	<b>12</b>
<b>6.</b>	<b>Function and system overview</b> .....	<b>13</b>
6.1.	Bus module MBM.....	13
6.2.	Interlocking/locking module MGB2-I/MGB2-L.....	13
6.3.	MCM expansion modules.....	14
6.4.	Submodules MSM.....	14
6.5.	Dimension drawing for bus module MBM .....	14
<b>7.</b>	<b>Mounting</b> .....	<b>15</b>
<b>8.</b>	<b>Protection against environmental effects</b> .....	<b>15</b>
<b>9.</b>	<b>Controls and indicators</b> .....	<b>16</b>
9.1.	DIP switches .....	16
9.2.	LED displays .....	16
<b>10.</b>	<b>Electrical connection</b> .....	<b>17</b>
10.1.	Notes about  .....	17
10.2.	Bus connections .....	18
10.2.1.	Terminal assignment for version with push-pull plugs.....	18
10.2.2.	Terminal assignment for version with 7/8" and M12 plugs, D-coded .....	18

10.2.3.	Terminal assignment for version with Power M12 plug (L-coded), 5-pin, and bus M12 plug (D-coded) .....	19
10.2.4.	Terminal assignment for version with Power M12 plug (L-coded), 4-pin, and bus M12 plug (D-coded) .....	19
10.3.	MLI connections .....	20
10.3.1.	Direct mounting .....	20
10.3.2.	Remote mounting.....	21
10.4.	Connecting modules .....	22
<b>11.</b>	<b>Setup .....</b>	<b>23</b>
11.1.	Teach-in operation .....	23
11.2.	Overview of the communication data .....	23
11.3.	Information on the related data sheets.....	24
11.4.	System layout and layout of the data areas in the control system .....	25
11.5.	PROFINET data bytes .....	27
11.6.	PROFIsafe data bytes .....	27
11.6.1.	Data block for PROFIsafe .....	27
11.7.	Integrating into PROFINET and PROFIsafe .....	28
11.8.	Configuring and setting parameters for modules and submodules .....	29
11.8.1.	Combining modules and submodules.....	29
11.8.2.	List of the parameters that can be set per module/submodule .....	33
11.9.	Line swap .....	34
11.10.	Replacing submodules .....	34
11.11.	Replacing modules.....	35
11.12.	Changing the configuration .....	35
<b>12.</b>	<b>Overview of data blocks for modules and submodules.....</b>	<b>36</b>
12.1.	Data blocks for bus module MBM.....	36
12.1.1.	Safe bits .....	36
12.1.2.	Non-safe bits .....	36
12.2.	Data blocks for interlocking/locking module MGB2-I / MGB2-L .....	37
12.2.1.	Safe bits .....	37
12.2.2.	Non-safe bits .....	37
12.3.	Data blocks for expansion module MCM .....	38
12.3.1.	Safe bits .....	38
12.3.2.	Non-safe bits .....	38
12.4.	Data blocks for submodules .....	39
12.5.	Replacing a bus module MBM without programming device.....	39
12.6.	Handle module teach-in operation (only for systems with locking module MGB2 unicode) .....	39
<b>13.</b>	<b>Diagnostics, troubleshooting and aids.....</b>	<b>40</b>
13.1.	Reset and restart.....	40
13.2.	Acknowledging errors .....	40
13.3.	Resetting system to factory settings (factory reset).....	40
13.4.	Diagnostics with the aid of the device web interface .....	41
13.4.1.	Using device web interface .....	41
13.4.2.	Using password .....	42

13.5.	General errors .....	43
13.6.	Teach-in errors and configuration errors.....	44
13.7.	Transponder errors .....	45
13.8.	Environment errors .....	45
13.9.	Communication errors.....	47
13.10.	Plausibility errors .....	48
13.11.	Submodule errors.....	49
13.12.	PROFINET errors .....	49
13.13.	PROFIsafe errors .....	50
<b>14.</b>	<b>Updating firmware .....</b>	<b>52</b>
14.1.	Running EUCHNER Device Update.....	52
<b>15.</b>	<b>Technical data .....</b>	<b>53</b>
<b>16.</b>	<b>Service .....</b>	<b>55</b>
<b>17.</b>	<b>Inspection and service .....</b>	<b>55</b>
<b>18.</b>	<b>Declaration of conformity .....</b>	<b>55</b>

## 1. About this document

### 1.1. Scope

This document is valid for all bus modules MBM-PN-..-MLI-... (PROFINET). It serves as a system and configuration manual for all module combinations that can be operated with this bus module.

These operating instructions, the document *Safety information*, the operating instructions for the modules connected and any associated data sheets form the complete user information for your system.

Series	Output family	Module connection type	Product version (hardware version)	Firmware version
MBM-...	...PN-...	...MLI-...	V2.1.X	V2.1.X



#### Important!

A firmware update might have been performed on your device. Make sure that the device documentation corresponding to the update is available and is observed.

#### 1.1.1. Notes on other product versions

Make sure to use the operating instructions valid for your product version. Please contact our Service department if you have any questions.

### 1.2. Target group

Design engineers and installation planners for safety systems on machines, as well as setup and servicing staff possessing special expertise in handling safety components as well as expertise in the installation, setup, programming and diagnostics of programmable logic controllers (PLCs) and bus systems.

### 1.3. Key to symbols

Symbol/depiction	Meaning
	Printed document
	The document is available for download at <a href="http://www.EUCHNER.com">www.EUCHNER.com</a>
 <b>DANGER</b> <b>WARNING</b> <b>CAUTION</b>	Safety precautions <b>Danger</b> of death or severe injuries <b>Warning</b> about possible injuries <b>Caution</b> Slight injuries possible
 <b>NOTICE</b> <b>Important!</b>	<b>Notice</b> about possible device damage <b>Important</b> information
<b>Tip</b>	Useful information

### 1.4. Supplementary documents

The overall documentation for this device consists of the following documents:

Document title (document number)	Contents	
Safety information (2525460)	Basic safety information	
Operating instructions (MAN20001743)	(this document)	
Operating instructions for the connected modules and their submodules	Device-specific information for the related module and the installed submodules.	
Declaration of conformity	Declaration of conformity	
Release notes	Any firmware update report	
Any supplementary data sheets	Item-specific information about deviations or additions	



**Important!**

Always read all documents to gain a complete overview of safe installation, setup and use of the device. The documents can be downloaded from [www.euchner.com](http://www.euchner.com). For this purpose, enter the doc. no. or the order number for the device in the search box.

## 2. Correct use

The bus module MBM-PN-.-MLI-... (PROFINET) is operated as an IO device on PROFINET (PROFIsafe). The bus module MBM communicates with the modules/submodules connected and evaluates all relevant information. It processes these data and then transmits them on the bus connected to a control system.

Before the device is used, a risk assessment must be performed on the machine, e.g. in accordance with the following standards:

- EN ISO 13849-1
- EN ISO 12100
- EN IEC 62061

Correct use includes observing the relevant requirements for installation and operation, particularly based on the following standards:

- EN ISO 13849-1
- EN ISO 14119
- EN IEC 60204-1

The bus module MBM is allowed to be combined only with suitable modules that have an MLI interface. You will find more detailed information on compatibility in the operating instructions for the related MLI device. See also *Table 1: Combination options for modules with MLI technology*. A maximum of 18 modules or submodules can be operated on one bus module MBM.

On the unauthorized modification of system components, EUCHNER provides no warranty for function.

The customer is responsible for the safe overall function, especially for the safe integration into the PROFIsafe environment.



**Important!**

- The user is responsible for the proper integration of the device into a safe overall system. For this purpose, the overall system must be validated, e.g. in accordance with EN ISO 13849-1.
- Correct use requires observing the permissible operating parameters (see chapter 15. *Technical data on page 53*).
- If a data sheet is included with the product, the information on the data sheet applies.

Table 1: Combination options for modules with MLI technology

Bus module	Base units	Handle module	Submodules	Submodules
		MGB2-H... from V1.0.0	MSM-P-... MSM-R-... MSM-N-...	MSM-K-...
MBM-.-MLI from V2.0.0	Interlocking/locking module MGB2-L-.-MLI/MGB2-L-.-MLI from V1.4.0	●	●	-
	Expansion module MCM-.-MLI	-	●	-
<b>Key to symbols</b>	●	Combination possible		
	-	Combination not possible		

## 3. Description of the safety function

The safety function of the bus module MBM comprises evaluating the safety data transmitted from the overall system (e.g. from installed guard locking devices, emergency stop devices, enabling switches, etc.) and forwarding these data to a bus system connected. The number of safe devices in an overall system is limited to 12. Depending on the modules and submodules connected, the overall system can include the following safety functions:

### 3.1. Safety functions in combination with an interlocking or locking module MGB2-I or MGB2-L

The following applies to the MGB2-L...:

#### Monitoring of guard locking and the position of the guard (interlocking device with guard locking according to EN ISO 14119)

▸ Safety function:

- If guard locking is released, safety bit  $LM\_FI\_UK$  (ÜK) = 0 (monitoring of the locking element).
- If the guard is open, safety bit  $LM\_FI\_SK$  (SK) = 0 (monitoring of the position of the guard).
- Guard locking can be activated only when the bolt tongue is located in the locking module (prevention of inadvertent locking position (faulty closure protection)).

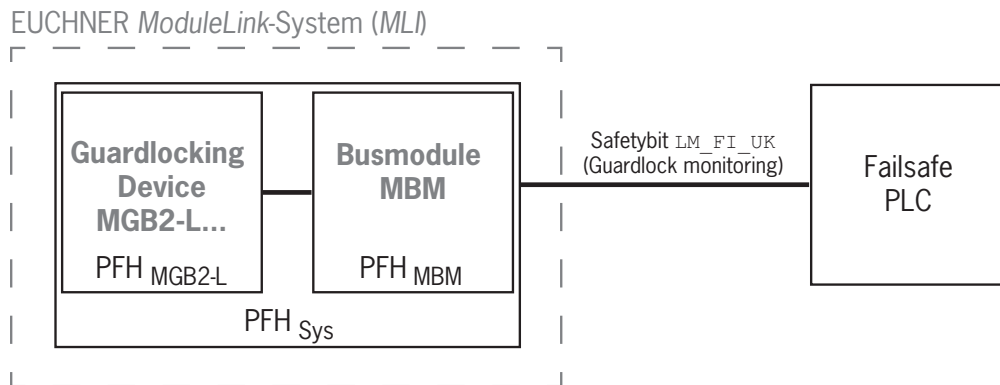

▸ Safety characteristics:

category , Performance Level , PFH

#### Control of guard locking (safety bit $LM\_FO\_CL$ ; applies only to guard locking devices according to the closed-circuit current principle)

▸ Safety function:

- If the device is used as guard locking for personnel protection, control of guard locking must be regarded as a safety function.

The safety level of guard locking control is determined by the system  $PFH_{sys}$  and by the external control (e.g. safe PLC).

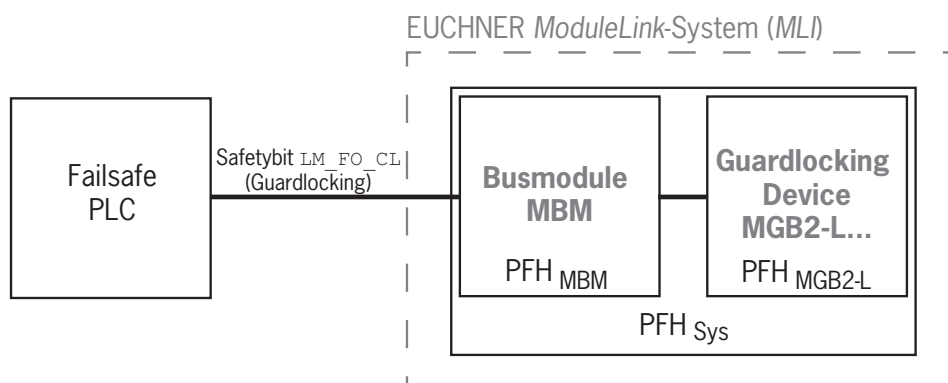

▸ Safety characteristics of the bus module and the locking module:

category, Performance Level, PFH

The following applies to MGB2-I... (or a correspondingly configured MGB2-L2):

**Monitoring of the guard position  
 (interlocking device according to EN ISO 14119)**

- Safety function: If the guard is open, safety bit  $LM\_FI\_SK$  (SK) = 0. (See chapter 12.2. Data blocks for interlocking/locking module MGB2-I / MGB2-L.)

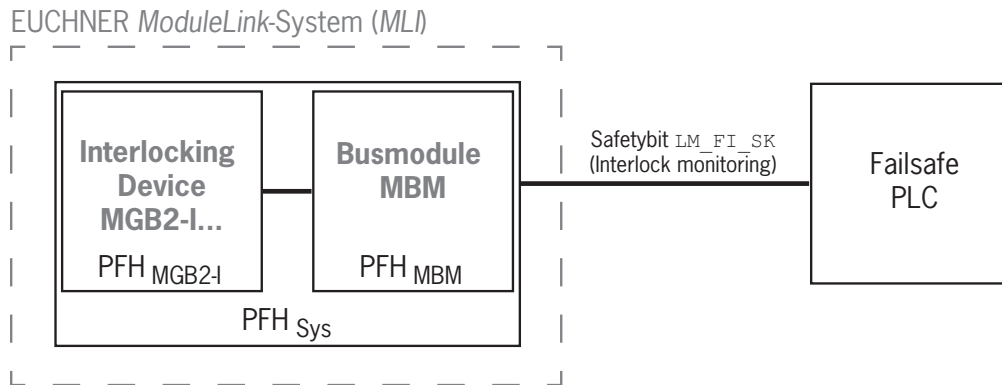

- Safety characteristics:  
 category, Performance Level, PFH  
 (you will find the reliability values according to EN 13849-1 in the technical data).

**3.2. Safety functions on submodules with emergency stop**

**Emergency stop  
 (emergency stop device according to EN ISO 13850)**

- Safety function: evaluation of emergency stop
- Safety characteristics:  $B_{10D}$  value of the emergency stop in the submodule (MSM) and PL, PFH, category and DC for the evaluation electronics (MLI modules) and the bus module (MBM)

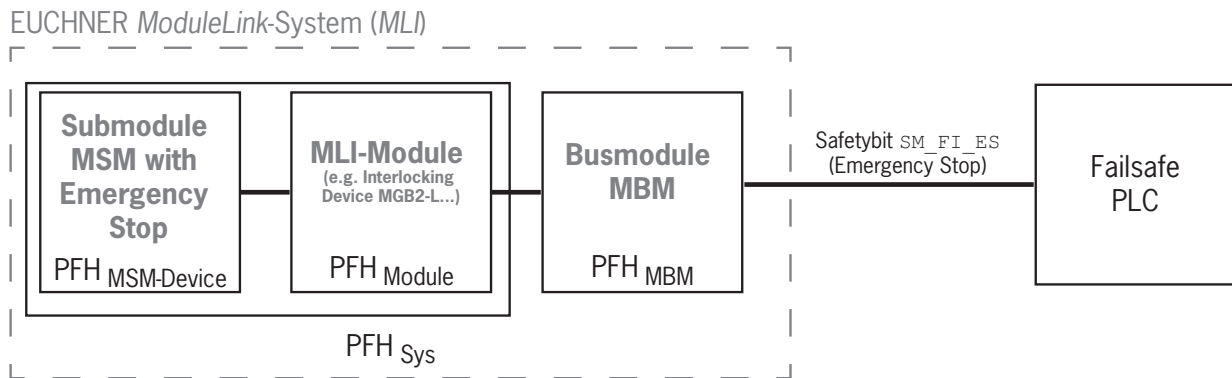



### 3.3. Safety functions on submodules with enabling switch

#### Enabling function

- › Safety function: evaluation of a connected enabling switch or other external electromechanical safety switches
- › Safety characteristics:  $B_{10D}$  value of the enabling switch (see operating instructions for the enabling switch) and PL, PFH, category and DC for the evaluation electronics (MLI modules) and the bus module (MBM)

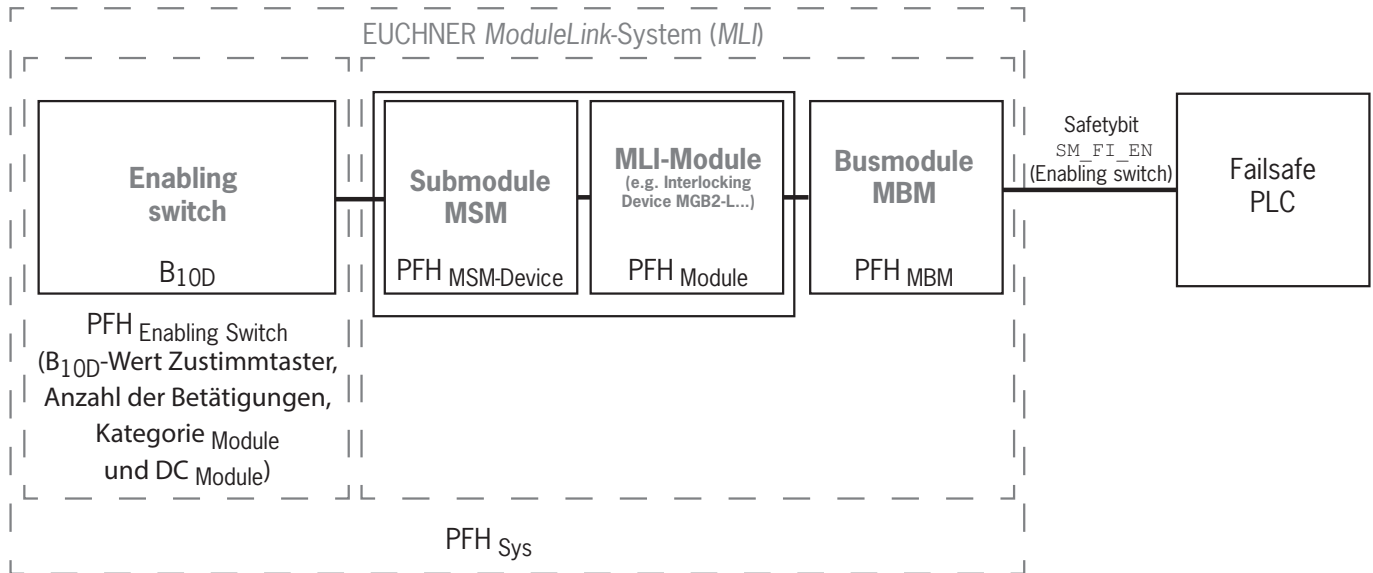

### 3.4. Safety functions on submodules with safe pushbuttons and switches (general)

#### Detection of the switch position

- › Safety function: evaluation of the switch position
- › Safety characteristics:  $B_{10D}$  value of the safe pushbutton or switch in the submodule (MSM) and PL, PFH, category and DC for the evaluation electronics (MLI modules) and the bus module (MBM)

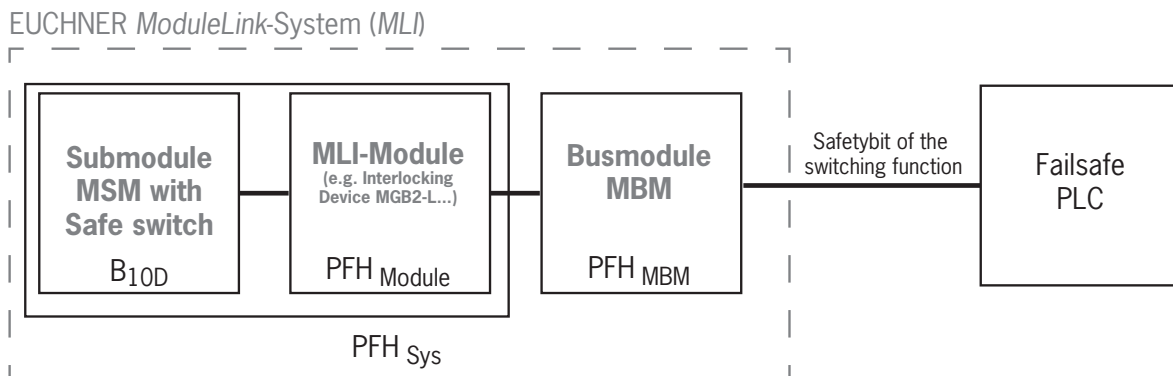

### 3.5. Safety functions on submodules without B<sub>10D</sub> (e.g. MSM-CKS2)

#### Detection of the switch position

- › Safety function: evaluation of the switch position
- › Safety characteristics: PFH<sub>MSM-Device</sub> value of the safe pushbutton or switch in the submodule (MSM) and PL, PFH, category and DC for the evaluation electronics (MLI modules) and the bus module (MBM)

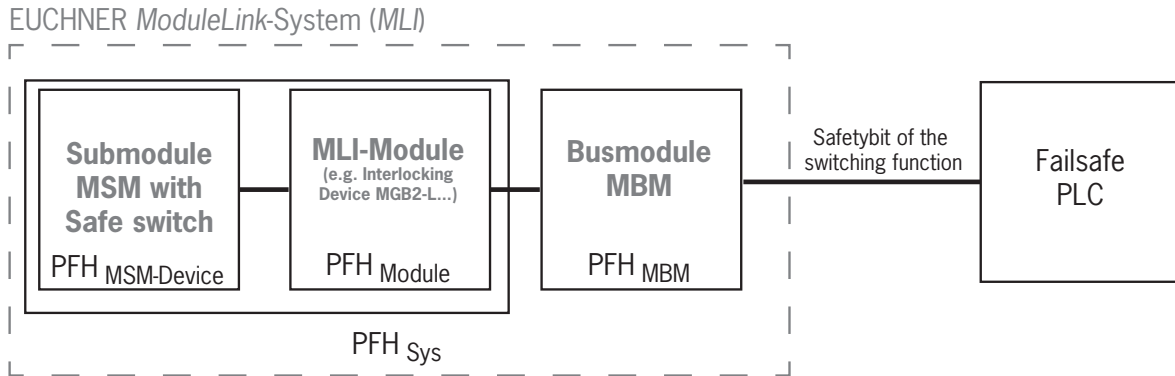

### 3.6. Safety functions on submodules with connection for OSSD safety switches

#### Detection of the switch position

- › Safety function: evaluation of the switch position
- › Safety characteristics: PFH<sub>MSM-Device</sub> value of the safe pushbutton or switch in the submodule (MSM) and PL, PFH, category and DC for the evaluation electronics (MLI modules) and the bus module (MBM)

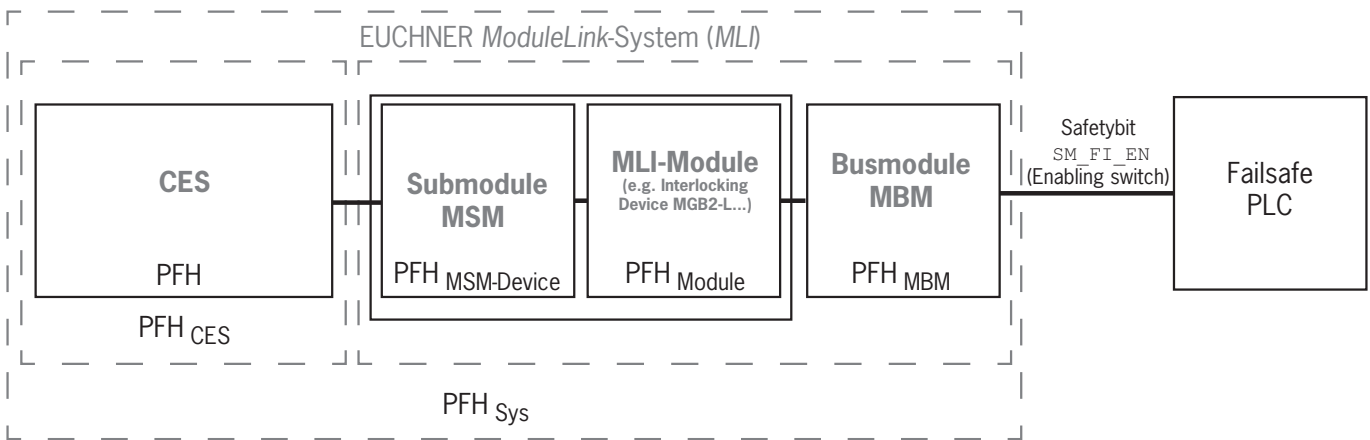

### 3.7. Determining safety characteristics of the overall system

The corresponding reliability values must be determined for each safety function in the overall system. Proceed as follows:

1. Refer to the data sheets or operating instructions for the system components containing the function for information on the reliability values for the related safety function.
2. Refer to the reliability value of the bus module MBM for the evaluation and forwarding of safety data.
3. Add together the values to a resulting reliability value  $PFH_{Sys}$

#### 3.7.1. Calculation example for the “monitoring of guard locking” safety function

$$PFH_{Sys} = PFH_{MGB2-L} + PFH_{MBM}$$

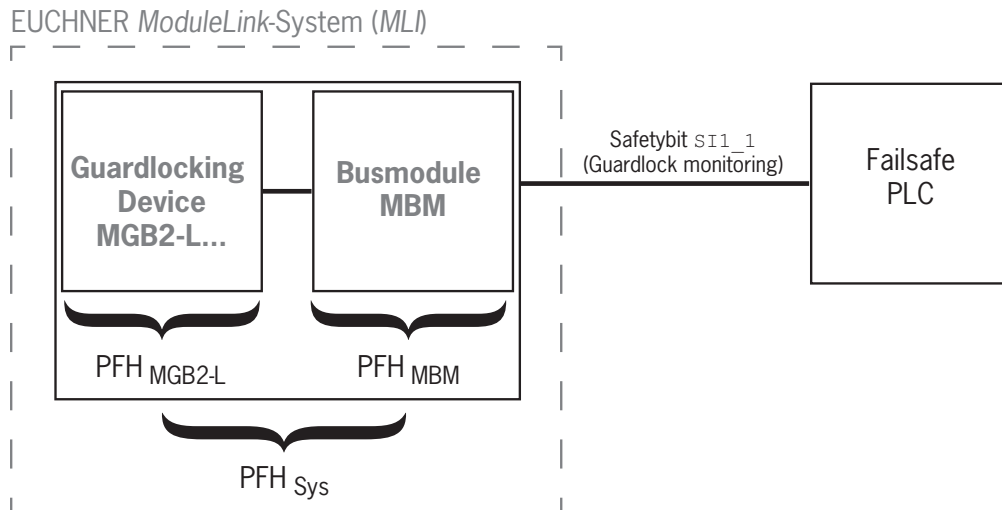

#### 3.7.2. Calculation example for the “emergency stop” safety function

$$PFH_{Sys} = PFH_{MSM-Device} + PFH_{MGB2-L} + PFH_{MBM}$$

To calculate the  $PFH_{MSM-Device}$  from the  $B_{10D}$  value, use the method in Annex C 4.2 of EN ISO 13849-1:2023.

The following applies:  $PFH_{MSM-Device} = f(\text{category}_{MGB2}; DC_{MGB2}; B_{10D}; n_{op})$

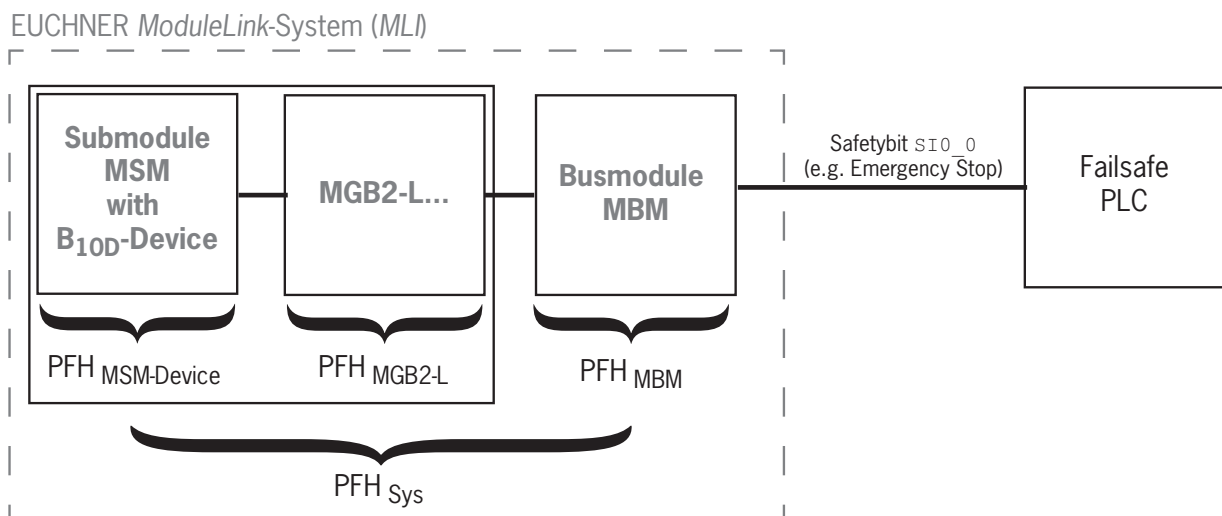

## 4. Exclusion of liability and warranty

In case of failure to comply with the conditions for correct use stated above, or if the safety regulations are not followed, or if any servicing is not performed as required, liability will be excluded and the warranty void.

## 5. General safety precautions

Safety switches fulfill personnel protection functions. Incorrect installation or tampering can lead to fatal injuries to personnel.

Check the safe function of the safeguard and, if necessary, other safety functions particularly

- › after any setup work
- › after every replacement of a component relevant to safety (also after rotating a submodule)
- › after an extended period without use
- › after every fault
- › after any change to the DIP switch settings
- › after every factory reset
- › after every firmware update

Independent of these checks, the safe function of the guard should be checked at suitable intervals as part of the maintenance schedule.



### WARNING

Danger to life due to improper installation or due to bypassing (tampering). Safety components fulfill a personnel protection function.

- › Safety components must not be bypassed, turned away, removed or otherwise rendered ineffective. On this topic pay attention in particular to the measures for reducing the possibility of bypassing according to EN ISO 14119:2013, section 7.
- › Mounting, electrical connection and setup only by authorized personnel possessing the following knowledge:
  - specialist knowledge in handling safety components
  - knowledge about the applicable EMC regulations
  - knowledge about the applicable regulations on operational safety and accident prevention.



### Important!

Prior to use, read the operating instructions and keep these in a safe place. Ensure the operating instructions are always available during mounting, setup and servicing. You can download the operating instructions from [www.euchner.com](http://www.euchner.com).

## 6. Function and system overview

An MLI system comprises at least the following components:

- › One bus module MBM
- › One module with MLI connection (e.g. interlocking or locking modules MGB2 or expansion modules MCM)

Modules can in turn contain submodules. Fig. 1 shows a typical system layout with one bus module MBM (1), one locking module MGB2-L... (2) and the submodules MSM (3) installed in it. A full system can comprise up to 18 modules or submodules.

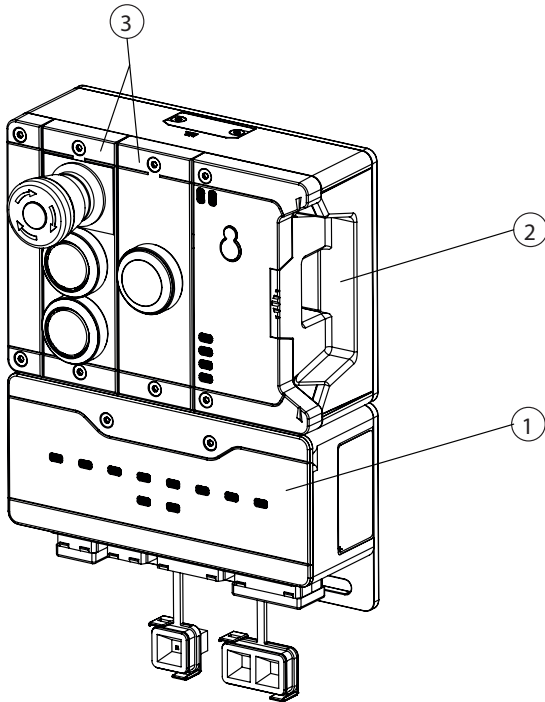

Fig. 1: Example system MGB2 Modular

### 6.1. Bus module MBM

Bus modules MBM have the following tasks:

- › Gateway to the bus connected
- › Central unit for control, evaluation and communication for the MLI modules connected
- › Central power supply for the MLI modules connected
- › IRT switch
- › Device web interface

### 6.2. Interlocking/locking module MGB2-I/MGB2-L

Together with a handle module, the interlocking module makes it possible to interlock movable guards. Together with a handle module, the locking module makes it possible to lock movable guards.

Interlocking/locking modules contain slots for submodules that provide additional functions.

For the exact functional description, refer to the operating instructions for your interlocking/locking module and the supplementary data sheets.

### 6.3. MCM expansion modules

Expansion modules MCM have space for up to four submodules. In this way, even more extensive control tasks can be realized.

### 6.4. Submodules MSM

Submodules MSM can be installed in modules that have one or more submodule slots. Using the submodules, it is possible to install additional functions in the modules. Typical function expansions include, e.g., emergency stop, pushbuttons, selector switches and indicators. For a detailed functional description, refer to the data sheet of the respective submodule.

### 6.5. Dimension drawing for bus module MBM

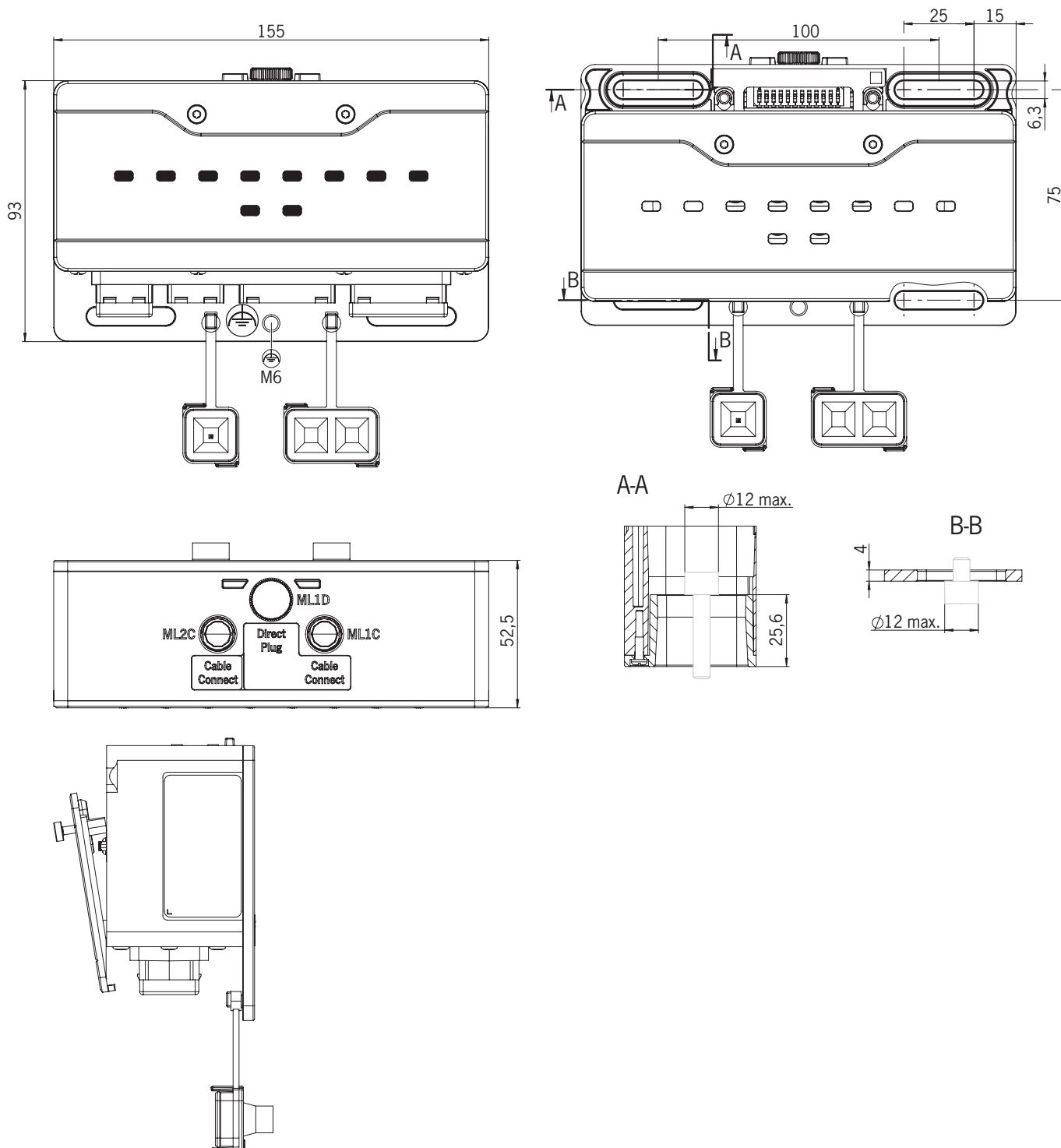

## 7. Mounting

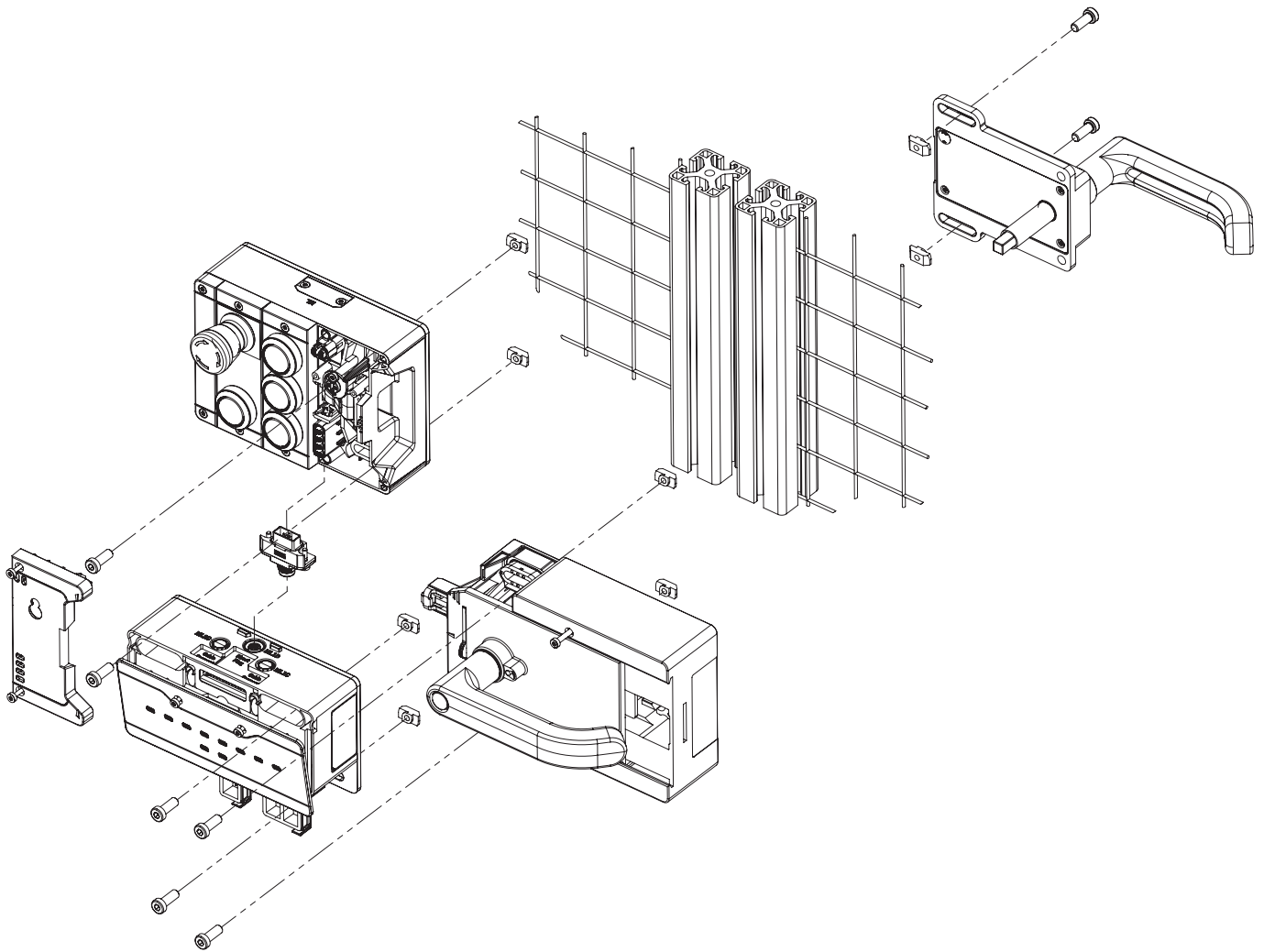

## 8. Protection against environmental effects

A lasting and correct safety function requires that the system must be protected against foreign bodies such as swarf, sand, blasting shot, etc., which can become lodged in the housing.

Pay attention to the following measures:

- Seal unused connections using the covers provided.
- Make sure the housing covers are correctly sealed and the cover screws are tightened to the necessary tightening torque.
- Cover the device during painting work.

## 9. Controls and indicators

### 9.1. DIP switches

The DIP switches have the following functions:

- › Setting the device's PROFINET address
- › Hardware reset to restore the device to the factory settings
- › Activating the device web interface

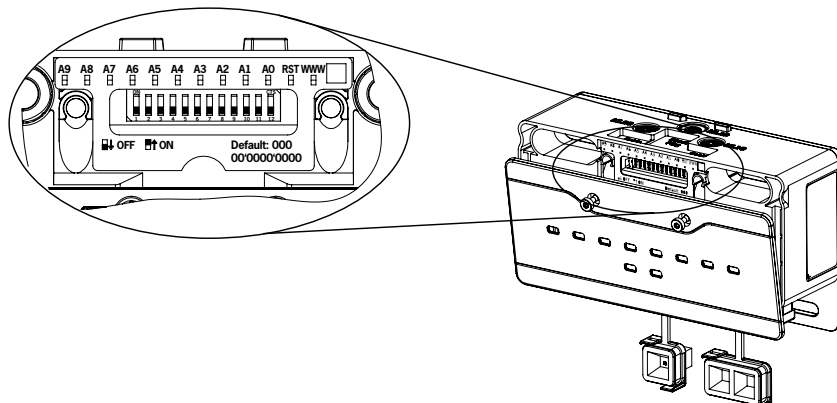

Switch	Description
A0 ... A9	Address switch, bits zero to nine For binary setting of the PROFINET address (factory setting: 0000000000)
RST	Factory reset (factory setting: off) For information on the factory reset, see chapter 13.3 on page 40.
WWW	Activate device web interface with extended diagnostic options (factory setting: off). For information on the device web interface, see chapter 13.4 on page 41.

### 9.2. LED displays

The LEDs indicate the device status and the communication status.

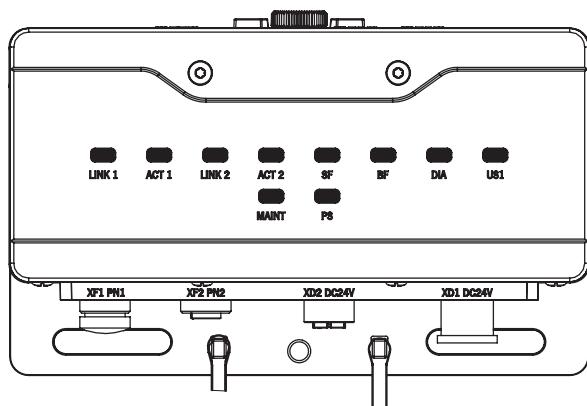

LED	Description
<b>Bus module MBM</b>	
LINK 1	Connection correct: statically On PROFINET device localization: flashing Color: green
ACT 1	Connection setup: flashing Color: yellow Connection setup complete, cyclical data traffic: statically On Color: yellow
LINK 2	Connection correct: statically On PROFINET device localization: flashing Color: green
ACT 2	Connection setup: flashing Color: yellow Connection setup complete, cyclical data traffic: statically On Color: yellow
SF	System fault: statically On (see chapter 13. <i>Diagnostics, troubleshooting and aids</i> ) Color: red
BF	Bus fault: statically on (see chapter 13. <i>Diagnostics, troubleshooting and aids</i> ) Color: red
DIA	Indicates errors Color: red
US1	Power Up: flashing Normal state: statically On Color: green
MAINT	Indicates the error flashing code Color: red/green/yellow
PS	Normal state: statically On Device passivated: flashing Control system communication error: flashing Color: green



## 10. Electrical connection

	<p><b>WARNING</b></p> <p>In the event of a fault, loss of the safety function due to incorrect connection.</p> <ul style="list-style-type: none"> <li>› Mounting must be performed only by authorized personnel.</li> <li>› Lay the connecting cables with protection to prevent the risk of short circuits.</li> </ul>
	<p><b>CAUTION</b></p> <p>Risk of damage to equipment or malfunctions as a result of incorrect connection.</p> <ul style="list-style-type: none"> <li>› All the electrical connections must either be isolated from the mains supply by a safety transformer according to EN IEC 61558-2-6 with limited output voltage in the event of a fault, or by other equivalent insulation measures.</li> <li>› Metal plugs must be used for the power supply via push-pull plugs.</li> <li>› Power devices which are a powerful source of interference must be installed in a separate location away from the input and output circuits for signal processing. The cable routing for safety circuits should be as far away as possible from the cables of the power circuits.</li> <li>› In order to avoid EMC interference, follow the EMC notes on devices in the immediate vicinity of the system and its cables.</li> <li>› To avoid EMC interference, the physical environmental and operating conditions at the installation site of the device must comply with the requirements according to the standard DIN EN 60204-1:2006, section 4.4.2/EMC.</li> <li>› The functional earth  must be connected. A bore hole with M6 thread is provided on the mounting plate for this purpose. Alternatively, the functional earth can also be connected via plugs XD1 and XD2 (5-pin). We recommend connecting the functional earth to the mounting plate.</li> </ul>
	<p><b>Important!</b></p> <ul style="list-style-type: none"> <li>› The power supply for additional PROFINET devices may be forwarded via the bus module MBM. The total supply current through the system must not be higher than specified in the technical data.</li> <li>› The total current consumption of all connected modules and submodules (including MBM) must not exceed the value specified in the technical data. Refer to the technical data of the respective device for information about the current consumption of the individual modules and submodules.</li> <li>› If the bus module MBM does not appear to function after the application of the operating voltage (e.g. Power LED does not illuminate), the device must be returned unopened to the manufacturer.</li> <li>› To ensure the stated degree of protection is achieved, the cover screws must be tightened to a tightening torque of 1 Nm. Unused connections must be fitted with the covers provided.</li> </ul>

### 10.1. Notes about

	<p><b>Important!</b></p> <ul style="list-style-type: none"> <li>› This device is intended to be used with a Class 2 power source in accordance with UL1310 <sup>1)</sup>. As an alternative an LV/C (Limited Voltage/Current) power source with the following properties can be used:             <ul style="list-style-type: none"> <li>- This device shall be used with a suitable isolating source in conjunction with a fuse in accordance with UL248. The fuse shall be rated max. 3.3 A and be installed in the max. 30 V DC power supply to the device in order to limit the available current to comply with the UL requirements. Please note possibly lower connection ratings for your device (refer to the technical data).</li> </ul> </li> </ul> <p><small>1) Note on the scope of the UL approval: only for applications as per NFPA 79 (Industrial Machinery). The devices have been tested as per the requirements of UL508 and CSA/ C22.2 no. 14 (protection against electric shock and fire).</small></p>
--	---

## 10.2. Bus connections

The bus module MBM includes the PROFINET connections (XF1 and XF2) and the power supply connections (XD1 and XD2).

Depending on version, connection is via

- push-pull plugs according to IEC 61076-3-117, variant 14
- 7/8" plugs and M12 plugs (D-coded) according to IEC 61076-2-101
- M12 plugs (L-coded), 5-pin, and M12 plugs (D-coded) according to IEC 61076-2-101
- M12 plugs (L-coded), 4-pin, and M12 plugs (D-coded) according to IEC 61076-2-101

The bus module MBM includes a PROFINET IRT switch for Ethernet connection.

### 10.2.1. Terminal assignment for version with push-pull plugs

Pin	Description
XF1.1	Receive Data RD+
XF1.2	Receive Data RD-
XF1.3	Transmit Data TD+
XF1.4	n.c.
XF1.5	n.c.
XF1.6	Transmit Data TD-
XF1.7	n.c.
XF1.8	n.c.
Functional earth on plug housing	

Pin	Description
XF2.1	Receive Data RD+
XF2.2	Receive Data RD-
XF2.3	Transmit Data TD+
XF2.4	n.c.
XF2.5	n.c.
XF2.6	Transmit Data TD-
XF2.7	n.c.
XF2.8	n.c.
Functional earth on plug housing	

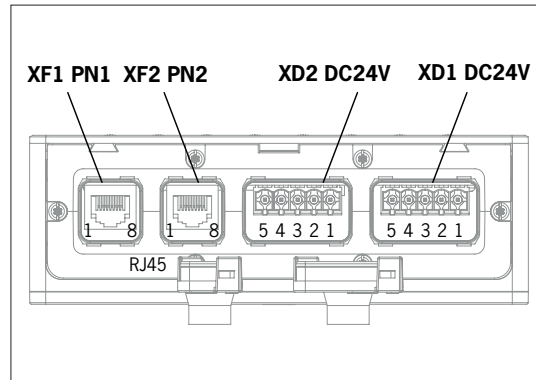

Pin	Description
XD1.1	L1 operating voltage DC 24 V
XD1.2	N1 operating voltage 0 V
XD1.3	L2 auxiliary voltage <sup>1)</sup> DC 24 V
XD1.4	N2 auxiliary voltage <sup>1)</sup> 0 V
XD1.5	Functional earth <sup>2)</sup>

Pin	Description
XD2.1	L1 operating voltage DC 24 V
XD2.2	N1 operating voltage 0 V
XD2.3	L2 auxiliary voltage <sup>1)</sup> DC 24 V
XD2.4	N2 auxiliary voltage <sup>1)</sup> 0 V
XD2.5	Functional earth <sup>2)</sup>

- 1) The auxiliary voltage is not required for the MGB2 system.  
 2) Optional; we recommend using the FE connection on the mounting plate instead.

### 10.2.2. Terminal assignment for version with 7/8" and M12 plugs, D-coded

Pin	Description
XF1.1	Transmit Data +TD
XF1.2	Receive Data +RD
XF1.3	Transmit Data -TD_N
XF1.4	Receive Data -RD_N
Functional earth on plug housing	

Pin	Description
XF2.1	Transmit Data +TD
XF2.2	Receive Data +RD
XF2.3	Transmit Data -TD_N
XF2.4	Receive Data -RD_N
Functional earth on plug housing	

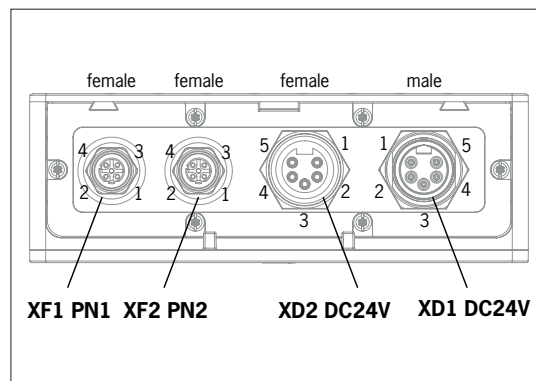

Pin	Description
XD1.1	N2 auxiliary voltage <sup>1)</sup> 0 V
XD1.2	N1 operating voltage 0 V
XD1.3	Looped through
XD1.4	L1 operating voltage DC 24 V
XD1.5	L2 auxiliary voltage <sup>1)</sup> DC 24 V

Pin	Description
XD2.1	N2 auxiliary voltage <sup>1)</sup> 0 V
XD2.2	N1 operating voltage 0 V
XD2.3	Looped through
XD2.4	L1 operating voltage DC 24 V
XD2.5	L2 auxiliary voltage <sup>1)</sup> DC 24 V

- 1) The auxiliary voltage is not required for the MGB2 system.

### 10.2.3. Terminal assignment for version with Power M12 plug (L-coded), 5-pin, and bus M12 plug (D-coded)

Pin	Description
XF1.1	Transmit Data +TD
XF1.2	Receive Data +RD
XF1.3	Transmit Data -TD_N
XF1.4	Receive Data -RD_N
Functional earth on plug housing	

Pin	Description
XF2.1	Transmit Data +TD
XF2.2	Receive Data +RD
XF2.3	Transmit Data -TD_N
XF2.4	Receive Data -RD_N
Functional earth on plug housing	

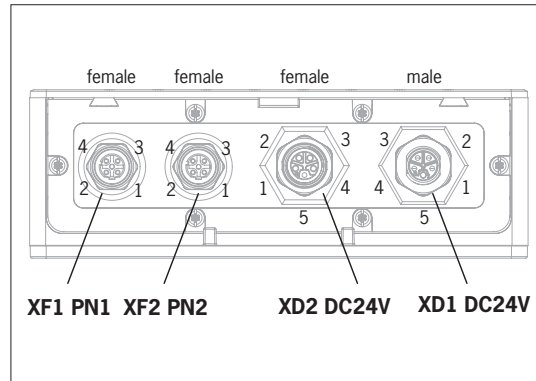

Pin	Description
XD1.1	L1 operating voltage DC 24 V
XD1.2	N2 auxiliary voltage <sup>1)</sup> 0 V
XD1.3	N1 operating voltage 0 V
XD1.4	L2 auxiliary voltage <sup>1)</sup> DC 24 V
XD1.5	Looped through

Pin	Description
XD2.1	L1 operating voltage DC 24 V
XD2.2	N2 auxiliary voltage <sup>1)</sup> 0 V
XD2.3	N1 operating voltage 0 V
XD2.4	L2 auxiliary voltage <sup>1)</sup> DC 24 V
XD2.5	Looped through

1) The auxiliary voltage is not required for the MGB2 system.

### 10.2.4. Terminal assignment for version with Power M12 plug (L-coded), 4-pin, and bus M12 plug (D-coded)

Pin	Description
XF1.1	Transmit Data +TD
XF1.2	Receive Data +RD
XF1.3	Transmit Data -TD_N
XF1.4	Receive Data -RD_N
Functional earth on plug housing	

Pin	Description
XF2.1	Transmit Data +TD
XF2.2	Receive Data +RD
XF2.3	Transmit Data -TD_N
XF2.4	Receive Data -RD_N
Functional earth on plug housing	

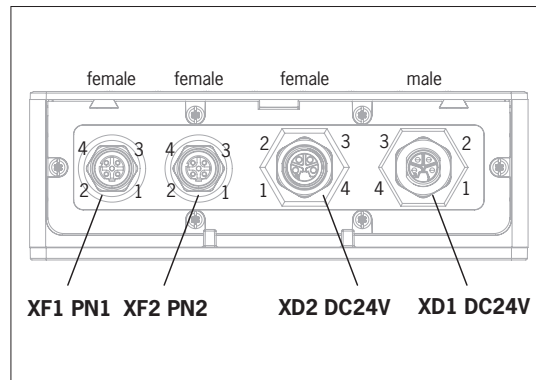

Pin	Description
XD1.1	L1 operating voltage DC 24 V
XD1.2	N2 auxiliary voltage <sup>1)</sup> 0 V
XD1.3	N1 operating voltage 0 V
XD1.4	L2 auxiliary voltage <sup>1)</sup> DC 24 V

Pin	Description
XD2.1	L1 operating voltage DC 24 V
XD2.2	N2 auxiliary voltage <sup>1)</sup> 0 V
XD2.3	N1 operating voltage 0 V
XD2.4	L2 auxiliary voltage <sup>1)</sup> DC 24 V

1) The auxiliary voltage is not required for the MGB2 system.

### 10.3. MLI connections

The MLI connections are used to connect modules to the bus module MBM. The sealing caps can be reordered (complete set AC-SET-BP-M12, order no. 156739).

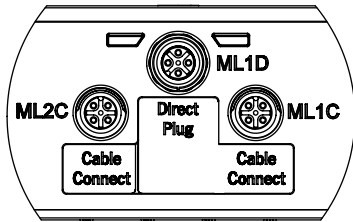

Connection	Description
ML1D (direct plug)	Module plug connector for direct mounting in a block. <b>Important!</b> Use only for direct mounting.
ML1C (cable connect)	Module plug connector for remote mounting (line 1).
ML2C (cable connect)	Module plug connector for remote mounting (line 2).

#### 10.3.1. Direct mounting

Pay attention to the following points on direct mounting:

- › Ensure the modules are flush with each other. Excessively large distances will reduce the degree of protection achievable. Caution: The modules are only loosely connected together.
- › Make sure a sealing cap is fitted to unused connections.
- › Mount each module on the mounting surface as stipulated.

Before direct mounting, the sealing cap must be removed from connection ML1D (see figure below).

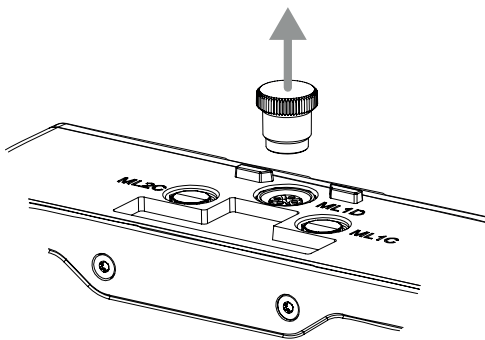

## 10.3.2. Remote mounting

Pay attention to the following points on remote mounting:

- › The maximum cable length for a line must not exceed 40 m.
- › Up to 3 base units can be operated per line. If you require a different configuration, contact our technical support team.
- › A maximum of 18 modules or submodules can be operated on one bus module MBM. Submodules count as one module here. Attention is to be paid to the maximum permissible total current consumption (see 15. Technical data).
- › The number of safe devices in an overall system is limited to 12.
- › Always use the module plug connector ML1C, ML2C or both for remote mounting.
- › Lay the cable so that it is protected against damage as far as possible.
- › Make sure a sealing cap is fitted to unused connections.
- › Make sure the connecting cables are correctly screwed into place to achieve the stated degree of protection.

Before remote mounting, the sealing cap must be unscrewed from connection ML1C. The sealing cap for connection ML1D is used as a tool for this purpose (see figure below). On the use of a second line, the sealing cap ML2C must also be unscrewed. Then the sealing cap for connection ML1D must be re-fitted.

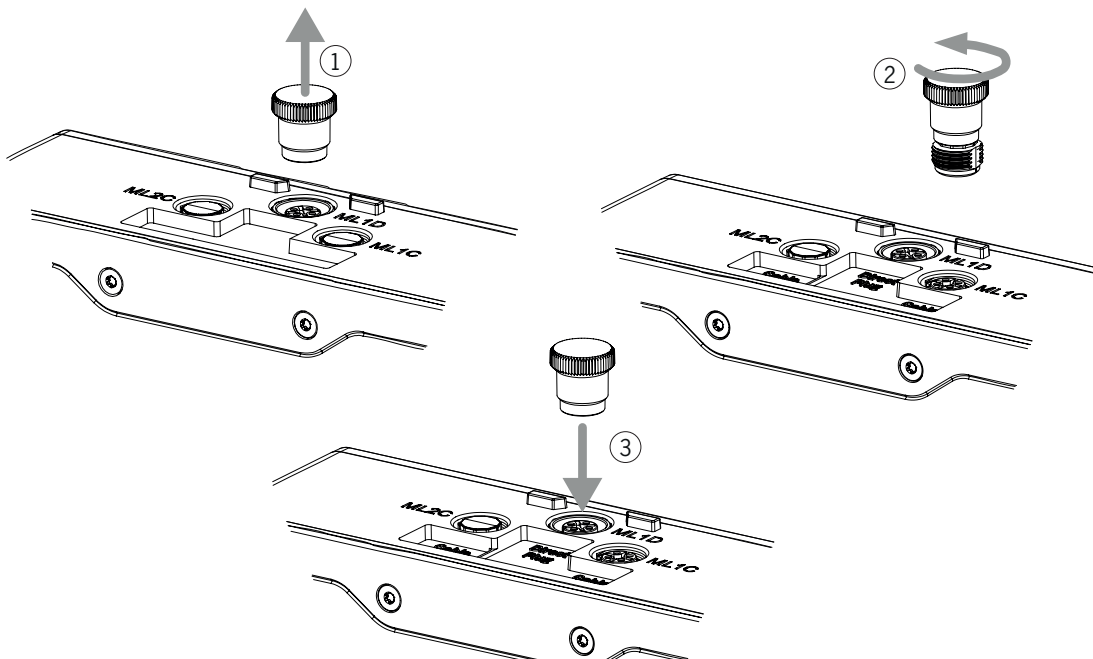

## 10.4. Connecting modules

Modules can either be connected together directly or using cables (see Fig. 2: Connecting modules).

Each module has a top and a bottom connection. You can use either the bottom or the top connection or both if the module is between two other modules.

The bottom module connector is already integrated. To use the top connection, change its position. If you want to use both connections, you must order a corresponding module connector. Use only the module connectors intended to interconnect the modules (see Table 2: Overview of module connectors). The maximum cable length for a line must not exceed 40 m.

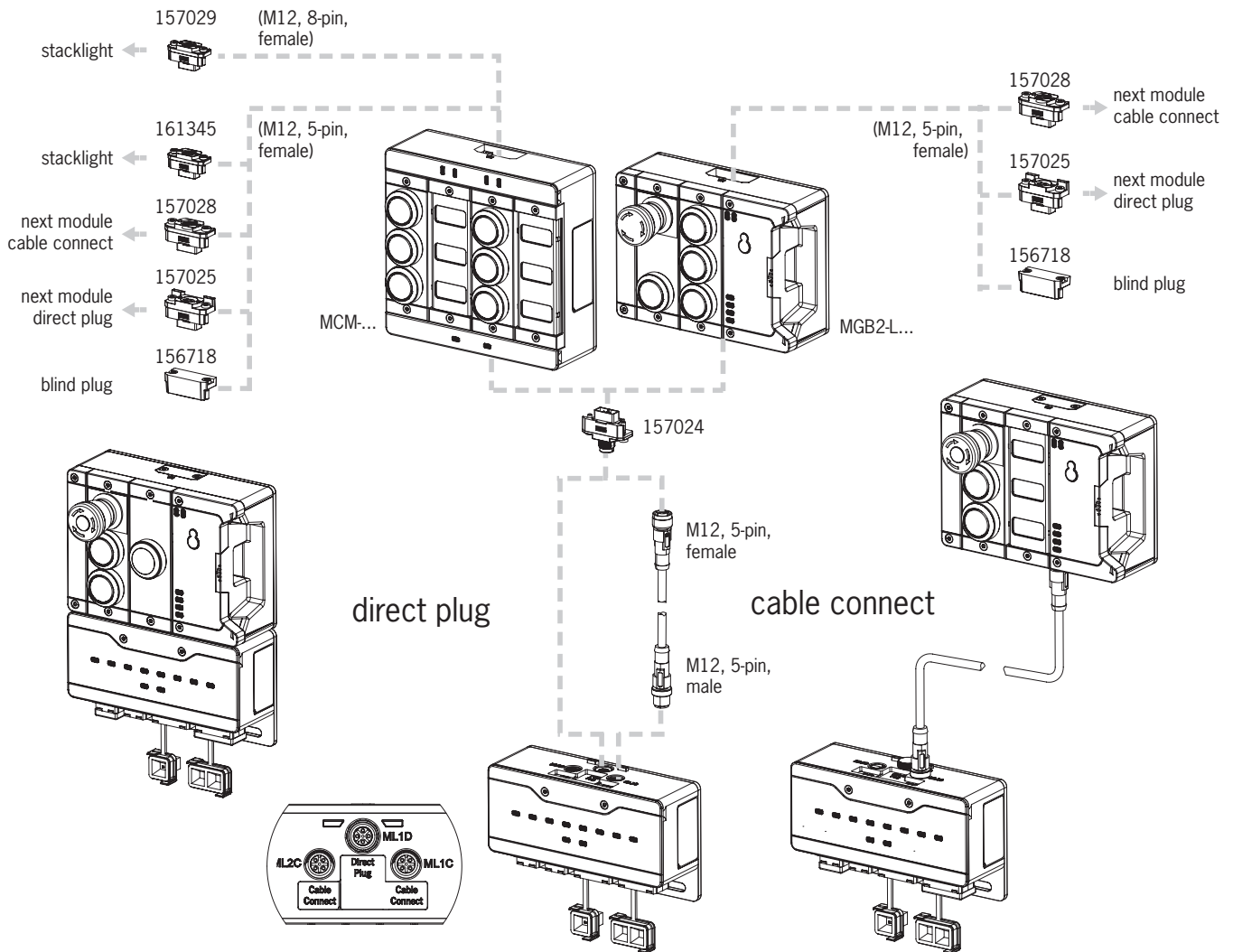

Fig. 2: Connecting modules

Table 2: Overview of module connectors

Function	Order no.	Included?
Module connector M12, 5-pin, plug	157024	1x *
Blanking cover	156718	1x *
Set with sealing caps for unused connections	156739	Yes
Module connector, 5-pin socket, for the direct connection of a further module	157025	No, must be ordered separately
Module connector M12, 5-pin socket, for the connection of a further module via a connecting cable	157028	
Module connector M12, 5-pin socket, for the connection of a stacklight	161345	
Module connector M12, 8-pin socket, for the connection of a stacklight	157029	
Connecting cable M12, 5-pin	See catalog or <a href="http://www.euchner.com">www.euchner.com</a>	
Connecting cable M12, 8-pin		

\* Not for MGB2...-Y0000-...

## 11. Setup

A typical MLI system usually consists of several modules and submodules. Which modules and submodules are used is determined by the bus module MBM on each system start.

To suit this configuration, in the configuration software for your control system, you must assemble the related data blocks for the communication data for the individual modules and submodules and, if necessary, set parameters. The individual modules and submodules are already included in the GSD file and must be applied in the planning software (e.g. TIA-Portal from SIEMENS) to suit your system layout. You will find an overview of the communication data in chapter 11.2. *Overview of the communication data.*

You will find an overview of the parameters that can be set for modules/submodules in chapter 11.8. *Configuring and setting parameters for modules and submodules on page 29.*

Some data blocks are permanently linked to the related module or submodule; you can add others optionally (see chapter 11.4. *System layout and layout of the data areas in the control system.*)

You can find which data blocks your modules or submodules contain on the data sheet for the respective device (see chapter 11.3. *Information on the related data sheets.*)

In chapter 11.4. *System layout and layout of the data areas in the control system on page 25*, it is explained how the communication data for a system are assembled.

From chapter 11.7. *Integrating into PROFINET and PROFIsafe on page 28*, it is explained how you configure and set the parameters for the individual modules and submodules in the configuration software for your control system.

### 11.1. Teach-in operation

The modules and submodules must be assigned to each other using a teach-in function before the system forms a functional unit.

During the teach-in operation, the module is in the safe state (all safe bits are not set).



#### Important!

- ▶ A system that has not yet been taught-in remains in the teach-in standby state until all modules have been taught-in during a power-up process. Systems that have already been taught-in must be reset to the factory setting in order to restore the teach-in standby state.
- ▶ Faulty modules or submodules can be replaced with identical modules or submodules without a teach-in operation.

### 11.2. Overview of the communication data

The associated input and output bits are listed on the data sheet for the respective module/submodule (see chapter 11.3. *Information on the related data sheets.*). The identifiers for the bits always have the same structure (see below).

The following example shows an error status bit [E] in a submodule [SM] for the switch position S1 [S1].

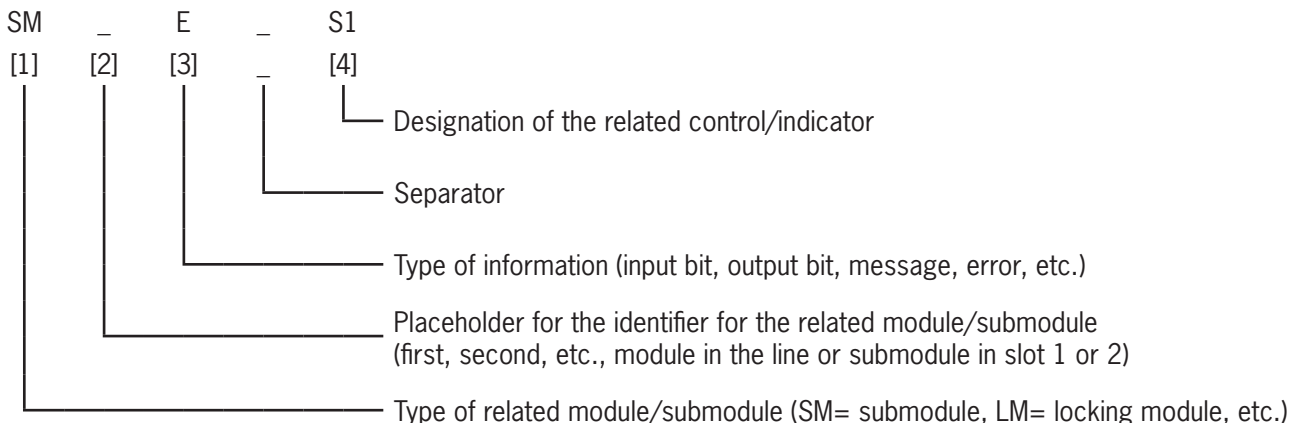

The individual abbreviations are explained in the following tables. You will find a detailed explanation of the individual bits on



the supplementary data sheet (see item 1 in Fig. 3 on page 24).

Bit identifiers for position [1]	Description
BM	Data from bus modules MBM
LM	Data from interlocking/locking modules MGB2-L1.../MGB2-L...
SM	Data from submodules MSM
EM	Data from expansion modules MCM

Bit identifiers for position [3]	Description
I	Input. Bit in the input area of the control system
O	Output. Bit in the output area of the control system
FI	Failsafe input. Safe bit in the input area of the control system (PROFIsafe bit)
FO	Failsafe output. Safe bit in the output area of the control system (PROFIsafe bit)
D	Diagnostics. Status bit for diagnostics messages
E	Error. Status bit for error messages
ACK	Acknowledge. Acknowledgment bit for confirmation of messages

Bit identifiers for position [4]	Description
S	Switch 1, 2, ...
H	Lamp 1, 2, ...
ES	Emergency stop
SK	Safe signal "Position of the bolt tongue" (guard closed and bolt tongue inserted)
UK	Safe signal "Position of guard locking"
CL	Guard locking control
EN	Enabling switch
SYS	System
ER	Escape release
ML	Module connection (MLI)
SM	Submodule

### 11.3. Information on the related data sheets

In addition to the operating instructions, you will find all item-specific information on the data sheets. This information includes, along with the modules and submodules installed, information on compatibility (connection type) and on the communication data that the related module exchanges with the bus module MBM. The following example data sheets show where this information is given.

**Datenblatt / Data Sheet MGB2-L1-MLI-U-Y0000-BJ-136776**  
**MGB2-L2-MLI-U-Y0000-BJ-156392**  
**MGB2-L1-MLI-M-Y0000-BJ-158698**  
**MGB2-L2-MLI-M-Y0000-BJ-158711**

Bezeichnung Designation	Beschreibung Description
LM	Zuhaltmodul Locking module
E_G	Fehler generell Error generally
E_ES	Fehler Fluchterhebung Error escape release
E_SM1	Fehler Submodul 1 Error sub module 1
E_SM0	Fehler Submodul 0 Error sub module 0
I_LK	Eingang UK Input UK
I_SK	Eingang SK Input SK
D_RLN	Diagnose Ritzmode Diagnostic ritzmode
L_L	Stellung Zuhaltung Locking position
L_OT	Stellung Regel Tongue position
L_OD	Stellung Tür Door position
FI_LK	Sicherer Eingang UK Failsafe input UK
FI_SK	Sicherer Eingang SK Failsafe input SK
ACK_G	Fehlererkennung generell Acknowledgment generally
ACK_ER	Quittierung Fluchterhebung Acknowledgment escape release
O_CL	Ausgang Zuhaltungssteuerung Output locking-control
FO_CL	Sicherer Ausgang Zuhaltungssteuerung Failsafe output locking-control

**Übersicht der Kommunikationsdaten (Nur bei Systemen mit einem Busmodul MBM):**  
**Overview of the communication data (only for systems with a Bus module MBM):**

Input	Bit 7	Bit 6	Bit 5	Bit 4	Bit 3	Bit 2	Bit 1	Bit 0
Ethernet® standard	LM_E_G	LM_E_ER	LM_E_SM1	LM_E_SM0	LM_I_LK	LM_I_SK	LM_D_RLN	
1st Byte								
2nd Byte								
3rd Byte								
Diagnose Byte (pluggable)								

**Ethernet® SAFE**

Output	Bit 7	Bit 6	Bit 5	Bit 4	Bit 3	Bit 2	Bit 1	Bit 0
Ethernet® standard	LM_ACK_G	LM_ACK_ER						
1st Byte								
2nd Byte								
3rd Byte								
Diagnose Byte (pluggable)								

**Ethernet® SAFE**

Output	Bit 7	Bit 6	Bit 5	Bit 4	Bit 3	Bit 2	Bit 1	Bit 0
Ethernet® standard	LM_FO_CL							
1st Byte								
2nd Byte								
3rd Byte								
Diagnose Byte (pluggable)								

**Bezeichnung Anschlussstyp P**

Pos	Connection type P	Description
1	S1	KO/HAALT Taster beleuchtet Emergency stop illuminated
2	S2	Taster beleuchtet Push-button illuminated
3	S3	Taster beleuchtet Push-button illuminated

**Übersicht der Kommunikationsdaten (Nur bei Systemen mit einem Busmodul MBM):**  
**Overview of the communication data (only for systems with a Bus module MBM):**

Geräte definiert mit SW-ID: 136687 in Gerätebeschreibung  
 Device defined with SW-ID: 136687 in the device instructions

Input	Bit 7	Bit 6	Bit 5	Bit 4	Bit 3	Bit 2	Bit 1	Bit 0
Ethernet® standard			SM_E_S1					
1st Byte								
2nd Byte								
Diagnose Byte (pluggable)								

Fig. 3: Example data sheets, locking module (left) and submodule (extract, right)



## 11.4. System layout and layout of the data areas in the control system

Due to its modular layout, the MLI system offers you a very large degree of flexibility. This flexibility also applies to the use of the communication data. The data areas that the system occupies in your control system are dependent on your system layout.

Every module has fixed communication data that are permanently assigned when the modules are combined in the configuration software for your control system. For some modules and submodules, there are also optional data that you can evaluate. These can be more detailed diagnostic functions, for example.

The following graphic is intended to make it clear which rules must be used to combine the data blocks from the individual modules and submodules. Here a differentiation is made between non-safe PROFINET data and safe PROFIsafe data.

While PROFINET data are always incorporated by bytes ("block #1 ... #4"), the data are always incorporated by individual bits for PROFIsafe data ("single bits" in the figure below). This means you must make sure you provide enough safe memory for PROFIsafe data.

The following example shows a typical system layout with the bus module (BM1) to which two locking modules (LM1 and LM2) are connected on one line. The first locking module (LM1) also contains a submodule (SM1) with one emergency stop and two pushbuttons. Based on this example, you can see the composition of the communication data.

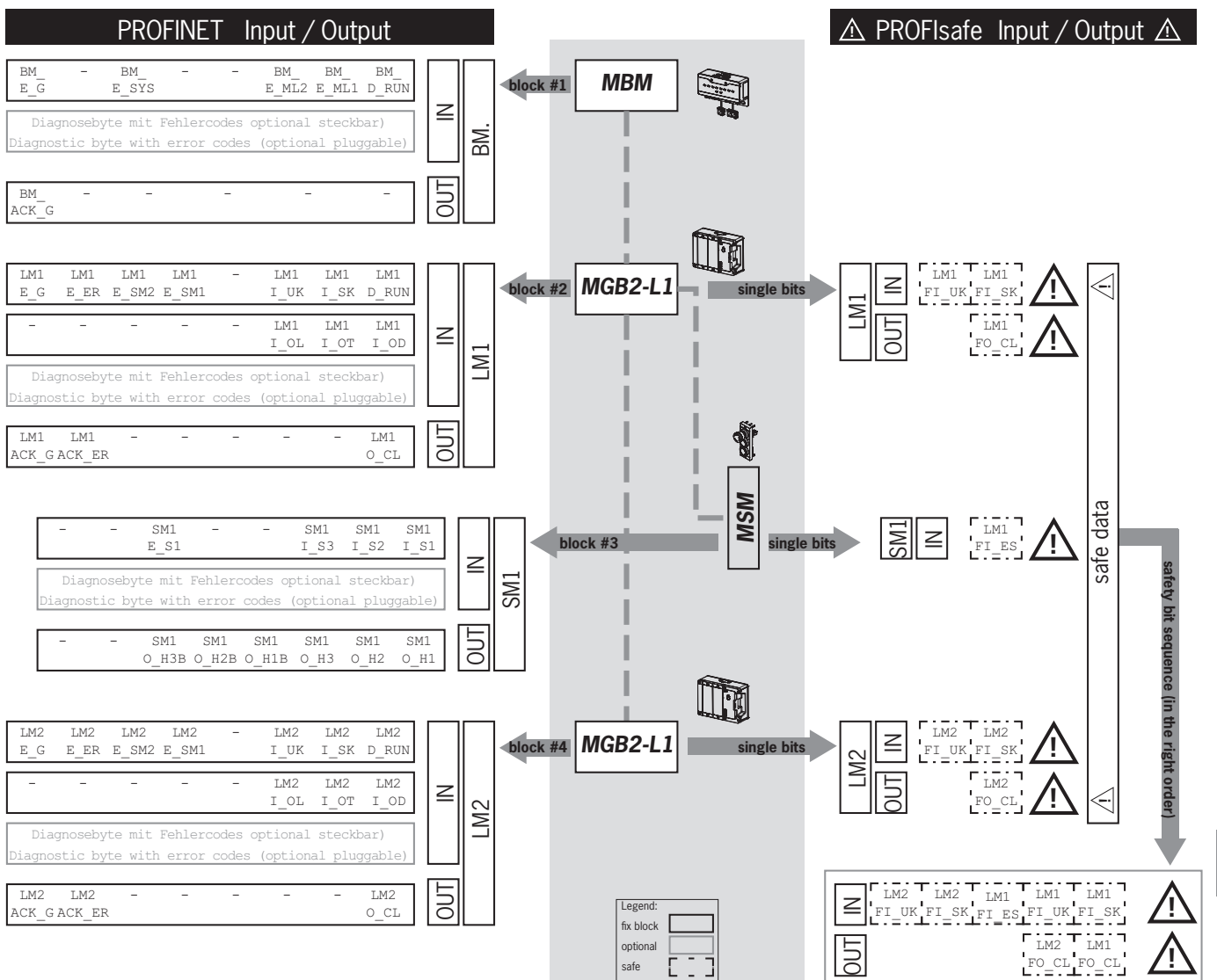

The individual data blocks or bits are always combined in the same sequence as the system layout. Here the counting is always started at the bus module (1) and then continued from the first to the last modules on a line. If there are two lines, the complete first line on ML1C (2...4 in the figure below) is counted first and then the complete second line on ML2C (5...7 in the figure below). Submodules in a module are counted immediately after the module in which they are inserted before the count continues with the next module. For submodules, the SLOT number defines the sequence.

The following figure is intended to clarify the counting sequence. In chapter 11.8. *Configuring and setting parameters for modules and submodules on page 29*, it is explained in detail how this aspect functions.

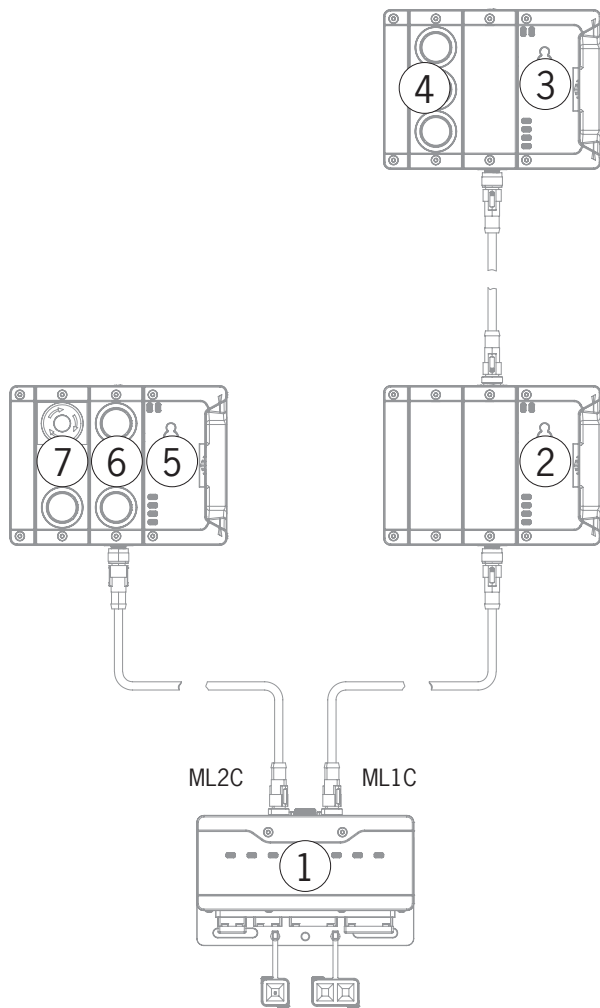

## 11.5. PROFINET data bytes

Each module or submodule sends specific, non-safe communication data. The following chapters provide an overview of the most important module types and their data. You can find item-specific information on which data blocks your modules or submodules contain on the supplementary data sheet (see chapter 11.3. *Information on the related data sheets*).

The following modules can be present in various combinations in an MLI system:

- A bus module MBM (contains everything necessary for a bus connection).
- Several interlocking/locking modules, MGB2-I or MGB2-L (together with the handle module, they form an interlocking device with or without guard locking).
- Several expansion modules MCM
- Several submodules MSM

Each module or submodule occupies a certain number of PROFINET data bytes in the input and output areas of the control system.

With some modules and submodules, you have the choice between a **standard configuration (basic)** that has basic status, signaling and control functions or an **extended configuration** that also contains an additional byte with exact error codes for diagnostic purposes.

## 11.6. PROFIsafe data bytes

Safe PROFIsafe data are transmitted in addition to the non-safe PROFINET data. These data include all information on the position of the bolt tongue and guard locking on an interlocking or locking module MGB2, emergency stop and enabling switch, for example.

While PROFINET data are always incorporated by bytes, the data for PROFIsafe are always incorporated by individual bits. This means you must make sure you provide enough safe memory for PROFIsafe data.

The following PROFIsafe data blocks are provided:

- 2 input bytes and 2 output bytes
- 4 input bytes and 4 output bytes
- 8 input bytes and 8 output bytes

4 bytes of PROFIsafe internal data are always appended to these device-specific data blocks.

The bus module supports PROFIsafe version 2.6.1 as standard. If your control system does not support this version, the respective modules for version 2.4 are also available from us under "Legacy" in the GSD.

All device-specific data bits are present in parallel in the non-safe PROFINET data area and can be used as status bits there.



### Important!

Never use the status bits for safety functions!



### 11.6.1. Data block for PROFIsafe



### Important!

For the scope of the safe bits, refer to the associated data sheet for your device or set. Use only bits that are specified according to the data sheet. Safe bits are marked there with a warning symbol and bounded with a dashed line.

**11.7. Integrating into PROFINET and PROFIsafe**

	<p><b>NOTICE</b></p> <p>The parameters “Update time” and “F-WD-Time” have a decisive effect on the reaction time of the safety function. The safety function could be lost if the reaction times are too long.</p> <p>You will find a list of all parameters that can be set in chapter 11.8.2 on page 33.</p>
	<p><b>Important!</b></p> <p>You will require the corresponding GSD file in GSDML format to integrate the system:</p> <ul style="list-style-type: none"> <li>▸ GSDML-Vx.x-EUCHNER-MBM_XXXXXX_TXX-YYYYMMDD.xml</li> </ul> <p><b>Important, pay attention to TIA version!</b></p> <p>GSD file up to TIA V13: GSDML-V2.33-EUCHNER-MBM_2512512_T13-YYYYMMDD.xml              GSD file from TIA V14: GSDML-V2.33-EUCHNER-MBM_2512512_T14-YYYYMMDD.xml</p> <p>You can find the GSD file in the download area at <a href="http://www.euchner.com">www.euchner.com</a>. Always use the latest GSD file. For new configuration, please use the GSD file GSDML-V2.41-EUCHNER-MBM-IRT_2512512-XXXXXXXX.xml or a newer version.</p> <p>The GSD file does not necessarily have to be updated on replacement. However, all of the newer functions might not be available in this case.</p> <p>Prior to setup, the GSD file must be imported into the configuration software for the control system (see 11.7. Integrating into PROFINET and PROFIsafe on page 28 and the control system manual).</p> <p>In the download area, you will find application examples in which integration into different control system environments is described.</p>

You must perform the following steps to integrate the system into PROFINET:

1. Configure the system with the configuration software for the control system and set the parameters.

The following PROFINET parameters must be set in the bus module parameters:

- Device name (factory setting from GSD file): [EUCHNER-MBM].
- IP address: optionally fixed or dynamic
- Update time:  
 recommendation [automatic]

The following PROFIsafe parameters must be set in the bus module parameters:

- F\_dest\_adr (PROFIsafe address)
- F\_WD\_Time (time during which the control system expects a response from the PROFIsafe device): [xxx ms]. Default value from GSD file: [600 ms].

2. Set the PROFIsafe address (F\_dest\_adr) on the bus module MBM using the DIP switches.

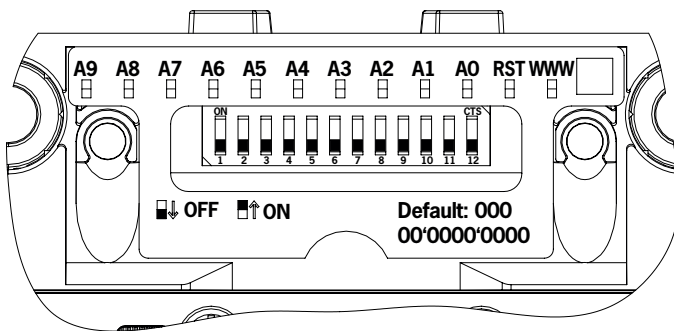

**Important:** Identical addresses must be set in the control system and on the device.

3. If necessary, set additional parameters for the individual modules. You will find an overview of the possible parameters in chapter 11.8.2. List of the parameters that can be set per module/submodule on page 33.
4. Save the configuration and transfer it to the system.

## 11.8. Configuring and setting parameters for modules and submodules

To be able to use the individual modules and submodules, these must be configured and the parameters set correspondingly in the configuration software for your control system. The following chapters describe these steps based on the example of the configuration software TIA-Portal from SIEMENS.

### 11.8.1. Combining modules and submodules

To be able to perform the following steps, first the bus module MBM must be dragged from the hardware catalog to the network overview.

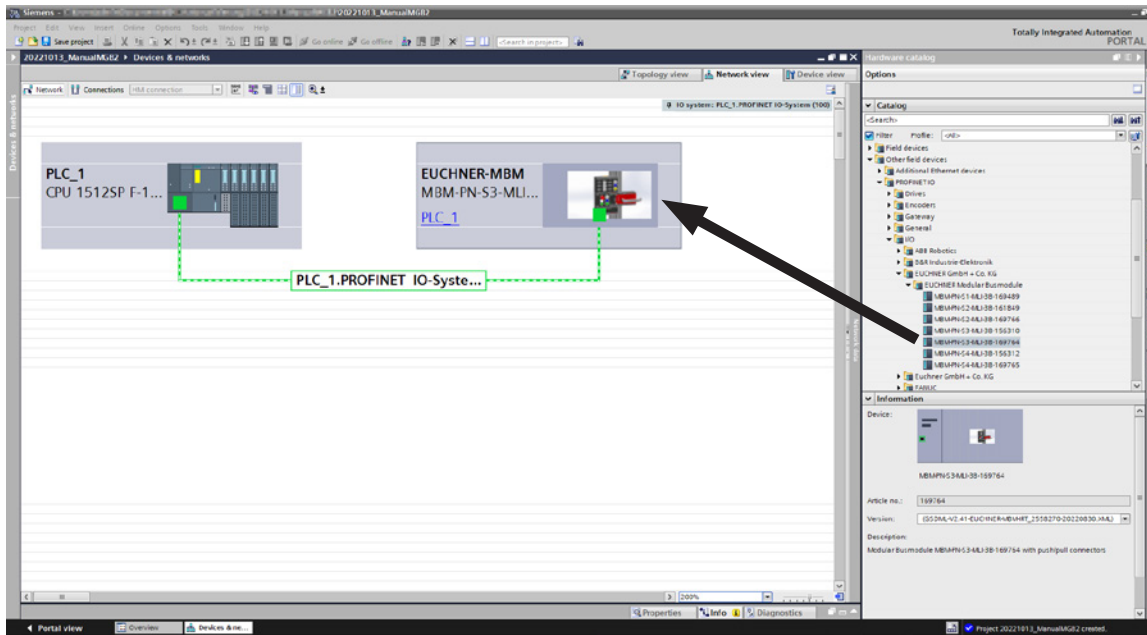

Here the MBM forms the head module.

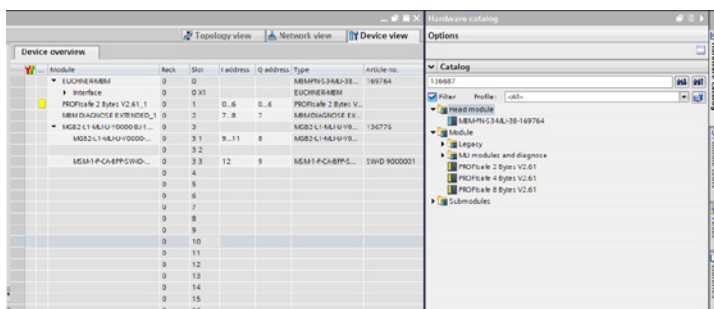

Drag a corresponding PROFIsafe data module to SLOT1. It must be large enough that there is space for the individual safe data bits for the modules/submodules in your system. On this topic, see also chapter 11.4. *System layout and layout of the data areas in the control system on page 25.*

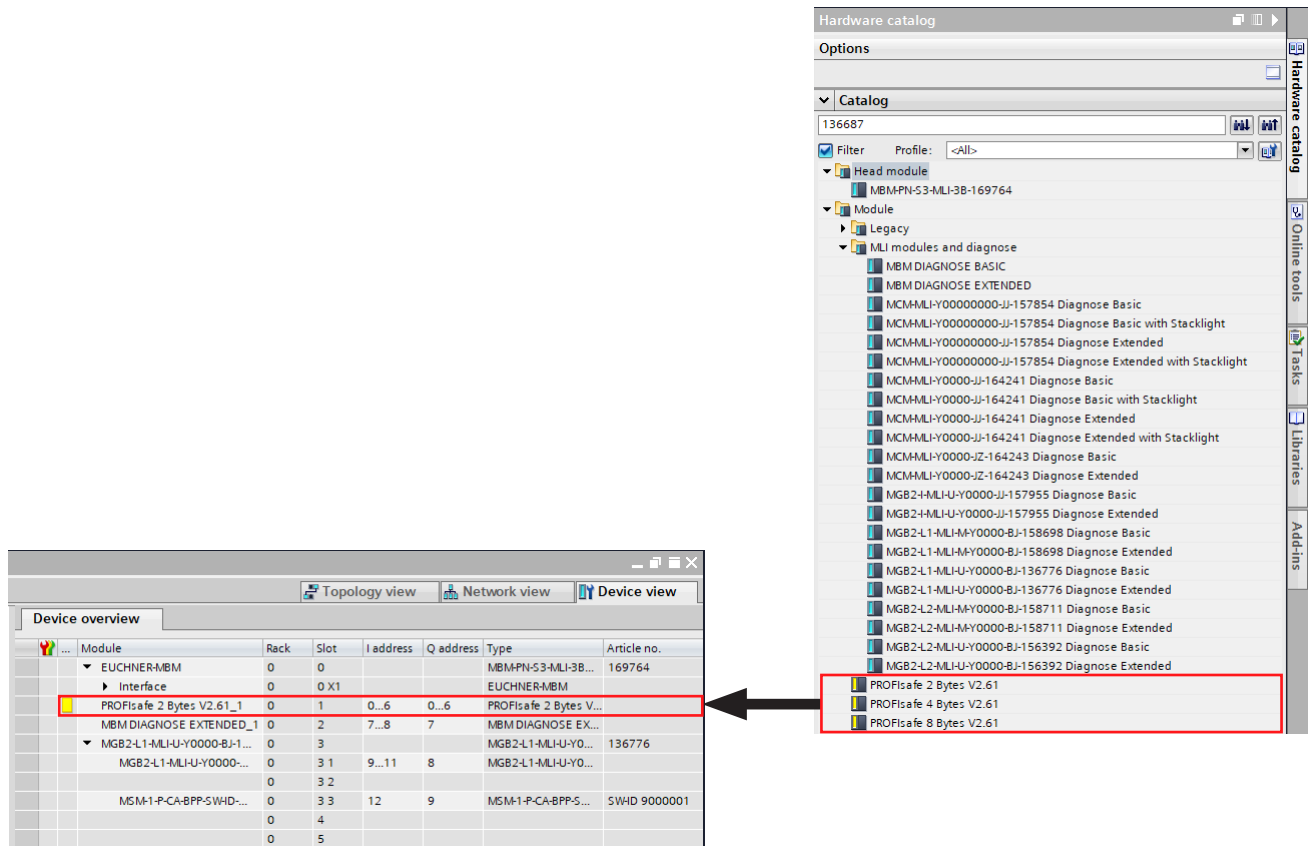

All other modules and submodules must be combined from the hardware catalog such that all devices can be seen in the correct sequence in the device overview. First create an exact representation of your system.

The individual modules are listed in the hardware catalog with order number and item designation. The submodules are listed with the software ID (SW-ID).

You will find this information on the type labels on the modules/submodules (see also chapter 11.4 on page 25).

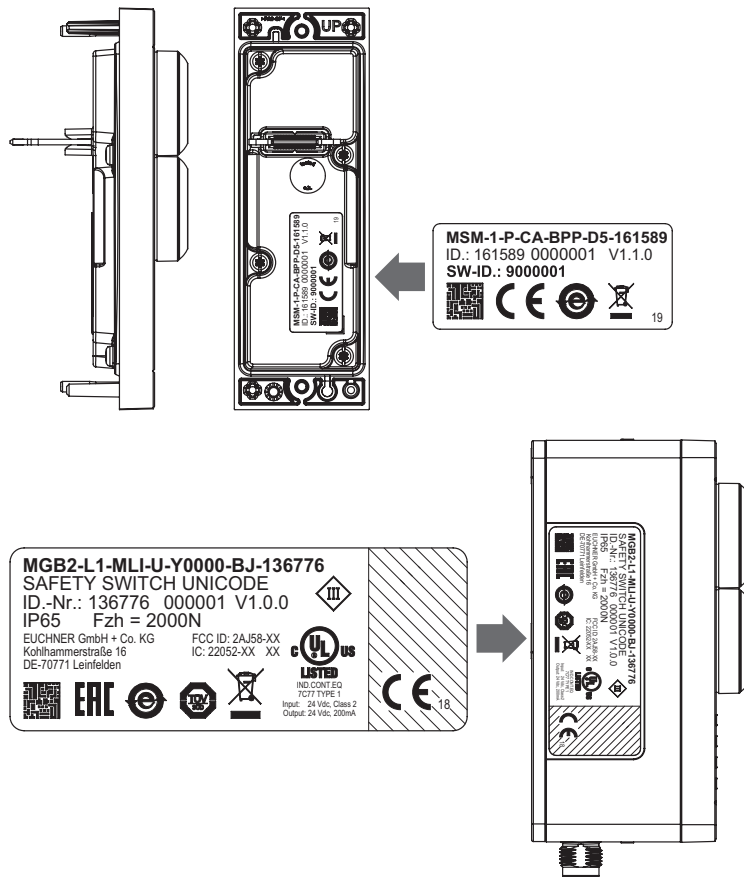

Fig. 4: Type labels on the modules/submodules (using MSM and MGB2 as examples)

Factory-equipped devices include an additional type label on the module. This label contains the SW IDs of the submodules in the module.

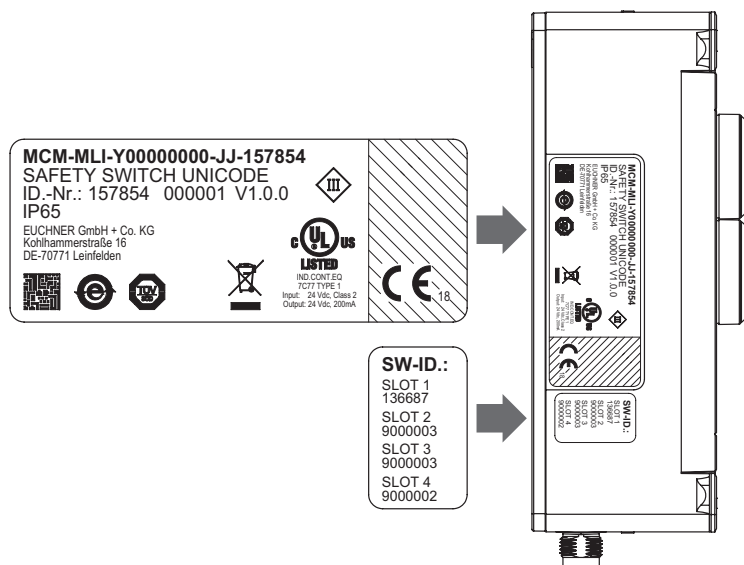

Fig. 5: Type labels on devices factory-equipped with submodules (using MCM as an example)

The figure below shows an example system layout.

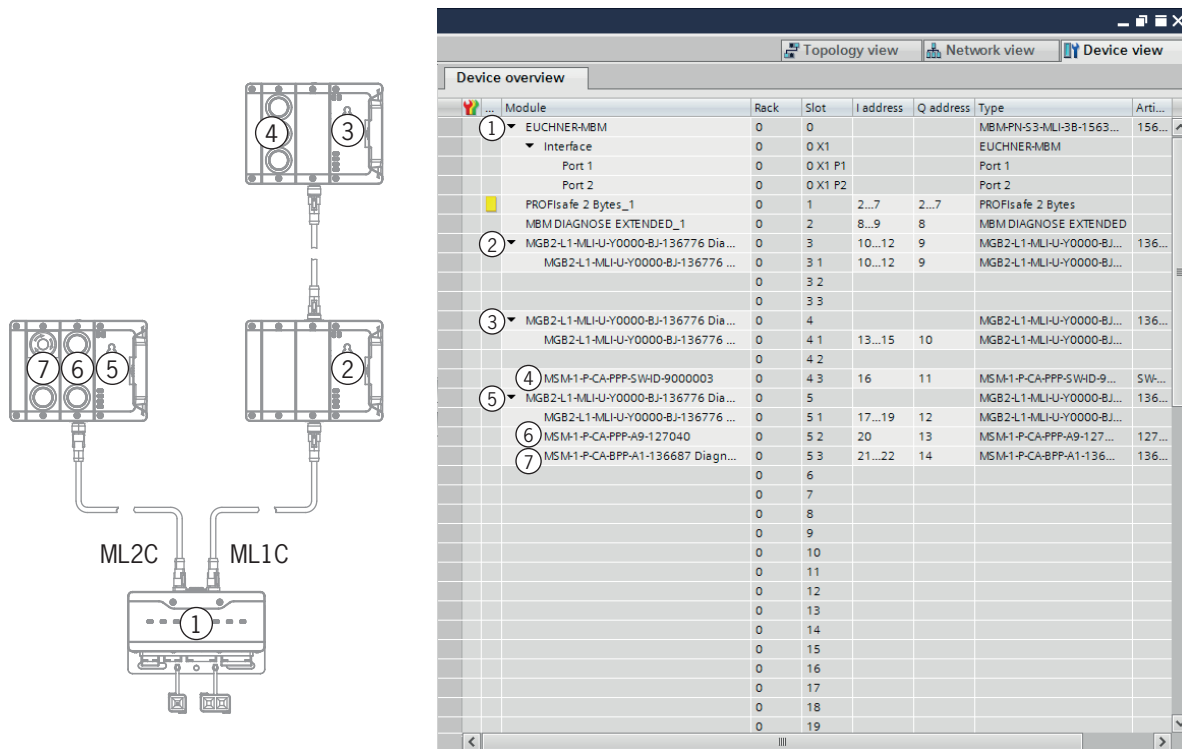

Fig. 6: Example system layout



### 11.8.2. List of the parameters that can be set per module/submodule

Module/submodule	PROFINET, PROFIsafe	Parameter	Setting range / [default value]	Description
Bus module MBM	PROFINET	Device name	Arbitrary designation	The device name can be assigned as required. Important: It must match the name in the configuration software. Tip: On replacing a faulty device, it is recommended to delete the name in the device (factory setting). If there is no name in the device, the existing name in the system for the previous device is entered automatically on starting. Prerequisite: Your PROFINET topology must be correctly configured.
		IP address		If a dynamic IP address is not assigned by your control system, a static IP address can be entered here.
		Update time	250 µs ... 512 ms [automatic]	Interval until the inputs/outputs are updated.
	PROFIsafe	F_dest_adr	1 ... 1022	Address of the PROFIsafe device. This address must match the DIP switch setting on the device.
		F_source_adr	1 ... 65534	Address of the control system connected to the device.
		F_WD_Time	150 ... 65535 ms [600]	Time within which the device must react to a control system request. Error if time exceeded.
Locking module MGB2	PROFIsafe	Solenoid control from the safety program <b>Important:</b> The setting has an effect on the safety function (see the operating instructions of your locking module for details)	Yes/No [Yes]	Parameter can be changed only for MGB2-L2 devices.
	PROFINET	Solenoid control from the standard program <b>Important:</b> The setting has an effect on the safety function (see the operating instructions of your locking module for details)	Yes/No [No]	<b>For MGB2-L1:</b> Here you can set whether the guard locking solenoid is also to be controlled using a non-safe bit. <b>For MGB2-L2:</b> Here you can set whether <b>a)</b> The guard locking solenoid is also to be controlled using a non-safe bit. For this purpose, "Yes" is set. <b>b)</b> The guard locking solenoid is to be controlled using only a non-safe bit. For this purpose, "Yes" is set. The "Solenoid control from the safety program" parameter must be set to "No" for this purpose. <b>c)</b> Guard locking is not to be used at all. For this purpose, "No" is set. The "Solenoid control from the safety program" parameter must also be set to "No" for this purpose.
		Escape release alarm	Yes/No [No]	Here you can set whether the actuation of the escape release is to cause an error message.
Submodules	PROFINET	Submodule alignment	Do not check/top/bottom [Do not check]	For submodules on which installation rotated by 180° cannot result in incorrect operation or functional problems, the alignment check can be disabled here. With "top" or "bottom" it is checked whether the position marking for S1 is at the "top" or "bottom" of the submodule (for marking, see data sheet for the submodule).
Submodules with illuminated control elements or submodules with indicators or stacklight for expansion module MCM	PROFINET	Flashing frequency H1	1 ... 255 (corresponds to 0.1 ... 25.5 Hz)	Here you can set the frequency at which the indicator is to flash.  Prerequisite: corresponding output bit for the flashing function must be set.
		Flashing frequency H2	1 ... 255 (corresponds to 0.1 ... 25.5 Hz)	
		Flashing frequency H3	1 ... 255 (corresponds to 0.1 ... 25.5 Hz)	
		Flashing frequency H4 (only for stacklight)	1 ... 255 (corresponds to 0.1 ... 25.5 Hz)	

## 11.9. Line swap

During the first starting process, the current MLI topology will be saved if the control system configuration matches the MLI topology.

When the system is restarted, the bus module detects if the position of an MLI device has changed or the device is being operated on a different MLI line.

The bus module additionally reports an error if devices were removed or added.

This is intended to prevent devices that were incorrectly connected after servicing from entering safe mode, for example.

If the system reports a line swap error, the MLI topology must be checked and corrected. Once the MLI topology matches the stored topology again, the system enters normal operation again after the restart.

Replacement devices are not recognized as errors if there are no major changes in the safe data of the MLI devices. In this case, the user is responsible for testing the safe function.

An intentional change of the MLI topology must be reset via factory reset using the DIP switches (see chapter 13.3. *Resetting system to factory settings (factory reset) on page 40*). The MLI topology will be saved the next time the system is started.

## 11.10. Replacing submodules



### CAUTION

Risk of damage to equipment or malfunction as a result of uncontrolled machine stop.

- The communication within the system is interrupted by the replacement of a submodule, and the safe bits are reset. If a process is running, this situation can result in an uncontrolled stop and damage to the installation or the product. Before replacement, make sure the installation is in a suitable operating status.



### NOTICE

Pay attention to the information on the replacement of a submodule in the operating instructions for the related module. On submodules with a safety function, the correct function must be tested after replacement before the system enters normal operation again.

The replacement of submodules MSM while in operation is also possible (pay attention to safety note above). As soon as the system detects a correct submodule, the submodule is ready for operation. The system reacts as follows on a replacement:

1. If the submodule MSM is removed, the SLOT LED illuminates red, interrupted by 1x green flash. In addition, the SF LED on the bus module MBM illuminates red.
2. If the submodule MSM contains a safety function, the related bit on the bus is cleared as soon as the submodule has been removed.
3. If an identical submodule is inserted with the same alignment, the fault display goes out and the bit is transmitted on the bus again to suit the actual situation.

## 11.11. Replacing modules



### CAUTION

Risk of damage to equipment or malfunction as a result of uncontrolled machine stop.

- The communication within the system is interrupted by the replacement of a module, and the safe bits are reset. If a process is running, this situation can result in an uncontrolled stop and damage to the installation or the product. Before replacement, make sure the installation is in a suitable operating status.

Modules (e.g. locking module or expansion module) can be replaced only in combination with a restart of the overall system. On the disconnection of the module connection, the system enters into a fault state. The related module and all downstream modules remain inactive until the overall system is restarted (fault state).

## 11.12. Changing the configuration

Changes to the configuration of the overall system must always be made in the configuration software for your control system (see chapter 11.7. *Integrating into PROFINET and PROFIsafe on page 28*). Depending on the change, a factory reset might also be necessary.

## 12. Overview of data blocks for modules and submodules



### Important!

- › You will find the exact data structure for your device on the supplementary data sheet.
- › With some modules and submodules, you have the choice between a **standard configuration (basic)** that has basic status, signaling and control functions or an **extended configuration** that also contains an additional byte with exact error codes for diagnostic purposes.
- › The output data (OUT) evaluated internally in the bus module MBM are set to 0x00 (cleared) on:
  1. Power on (application of the power supply)
  2. PROFINET connection interruption (e.g. disconnection of terminal plug)
  3. PLC STOP (IOPS=BAD)

### 12.1. Data blocks for bus module MBM

#### 12.1.1. Safe bits

Bus modules do not have any dedicated safe bits.

#### 12.1.2. Non-safe bits

Standard configuration (basic)	Extended configuration with additional diagnostics byte																																																																				
<table border="1" style="width: 100%;"> <tr> <td style="width: 25%;">BM_</td> <td style="width: 25%;">-</td> <td style="width: 25%;">BM_</td> <td style="width: 25%;">-</td> <td style="width: 25%;">-</td> <td style="width: 25%;">BM_</td> <td style="width: 25%;">BM_</td> <td style="width: 25%;">BM_</td> <td rowspan="2" style="text-align: center; vertical-align: middle;">IN</td> </tr> <tr> <td>E_G</td> <td></td> <td>E_SYS</td> <td></td> <td></td> <td>E_ML2</td> <td>E_ML1</td> <td>D_RUN</td> </tr> </table> <table border="1" style="width: 100%;"> <tr> <td style="width: 25%;">BM_</td> <td style="width: 25%;">-</td> <td style="width: 25%;">-</td> <td style="width: 25%;">-</td> <td style="width: 25%;">-</td> <td style="width: 25%;">-</td> <td style="width: 25%;">-</td> <td style="width: 25%;">-</td> <td rowspan="2" style="text-align: center; vertical-align: middle;">OUT</td> </tr> <tr> <td>ACK_G</td> <td></td> <td></td> <td></td> <td></td> <td></td> <td></td> <td></td> </tr> </table>	BM_	-	BM_	-	-	BM_	BM_	BM_	IN	E_G		E_SYS			E_ML2	E_ML1	D_RUN	BM_	-	-	-	-	-	-	-	OUT	ACK_G								<table border="1" style="width: 100%;"> <tr> <td style="width: 25%;">BM_</td> <td style="width: 25%;">-</td> <td style="width: 25%;">BM_</td> <td style="width: 25%;">-</td> <td style="width: 25%;">-</td> <td style="width: 25%;">BM_</td> <td style="width: 25%;">BM_</td> <td style="width: 25%;">BM_</td> <td rowspan="2" style="text-align: center; vertical-align: middle;">IN</td> </tr> <tr> <td>E_G</td> <td></td> <td>E_SYS</td> <td></td> <td></td> <td>E_ML2</td> <td>E_ML1</td> <td>D_RUN</td> </tr> </table> <p style="text-align: center; color: gray; font-size: small;">Diagnosebyte mit Fehlercodes optional steckbar          Diagnostic byte with error codes (optional pluggable)</p> <table border="1" style="width: 100%;"> <tr> <td style="width: 25%;">BM_</td> <td style="width: 25%;">-</td> <td style="width: 25%;">-</td> <td style="width: 25%;">-</td> <td style="width: 25%;">-</td> <td style="width: 25%;">-</td> <td style="width: 25%;">-</td> <td style="width: 25%;">-</td> <td rowspan="2" style="text-align: center; vertical-align: middle;">OUT</td> </tr> <tr> <td>ACK_G</td> <td></td> <td></td> <td></td> <td></td> <td></td> <td></td> <td></td> </tr> </table>	BM_	-	BM_	-	-	BM_	BM_	BM_	IN	E_G		E_SYS			E_ML2	E_ML1	D_RUN	BM_	-	-	-	-	-	-	-	OUT	ACK_G							
BM_	-	BM_	-	-	BM_	BM_	BM_	IN																																																													
E_G		E_SYS			E_ML2	E_ML1	D_RUN																																																														
BM_	-	-	-	-	-	-	-	OUT																																																													
ACK_G																																																																					
BM_	-	BM_	-	-	BM_	BM_	BM_	IN																																																													
E_G		E_SYS			E_ML2	E_ML1	D_RUN																																																														
BM_	-	-	-	-	-	-	-	OUT																																																													
ACK_G																																																																					

Input/output	Bit identifier	Meaning	Condition for setting	Condition for resetting
Input	BM_D_RUN	Diagnostics run mode	Device in operation	Device is not supplying any data
	BM_E_ML1	Error status bit Line 1	Fault on a module OR submodule OR EMC problem OR max. cable length exceeded	Automatic if error rectified OR acknowledgment bit BM_ACK_G is set for 500 ms (min. 350 ms and max. 750 ms)
	BM_E_ML2	Error status bit Line 2	Fault on a module OR submodule OR EMC problem OR max. cable length exceeded	Automatic if error rectified OR acknowledgment bit BM_ACK_G is set for 500 ms (min. 350 ms and max. 750 ms)
	BM_E_SYS	Error status bit Overall system	Any error in the overall system	Automatic if error rectified OR acknowledgment bit BM_ACK_G is set for 500 ms (min. 350 ms and max. 750 ms)
	BM_E_G	Error status bit General module error	Error in the module	Automatic if error rectified OR acknowledgment bit BM_ACK_G is set for 500 ms (min. 350 ms and max. 750 ms)
Output	BM_ACK_G	Acknowledgment bit for general errors	Control via PLC Resets error bit BM_E_G. Acknowledgment bit must be set for 500 ms (min. 350 ms and max. 750 ms).	

## 12.2. Data blocks for interlocking/locking module MGB2-I / MGB2-L

### 12.2.1. Safe bits

Input/output	Bit identifier	Meaning	Condition for setting	Condition for resetting
Input	LM_FI_SK	Safe input Door position	Door closed and bolt tongue inserted into interlocking/locking module	Door open OR error in transponder
	LM_FI_UK	Safe input Guard lock monitoring (only for MGB2-L)	Door closed AND locked	Guard locking open OR error in guard locking
Output	LM_FO_CL	Safe control of guard locking (only for MGB2-L)	Control via PLC Set = guard locking released Not set = guard locking active	

### 12.2.2. Non-safe bits

Standard configuration (basic)	Extended configuration with additional diagnostics byte																																																								
<table border="1"> <tr> <td>LM_E_G</td><td>LM_E_ER</td><td>LM_E_SM2</td><td>LM_E_SM1</td><td>-</td><td>LM_I_UK</td><td>LM_I_SK</td><td>LM_D_RUN</td> </tr> <tr> <td>-</td><td>-</td><td>-</td><td>-</td><td>-</td><td>LM_I_OL</td><td>LM_I_OT</td><td>LM_I_OD</td> </tr> <tr> <td>LM_ACK_ER</td><td>LM_ACK_G</td><td>-</td><td>-</td><td>-</td><td>-</td><td>-</td><td>LM_O_CL</td> </tr> </table>	LM_E_G	LM_E_ER	LM_E_SM2	LM_E_SM1	-	LM_I_UK	LM_I_SK	LM_D_RUN	-	-	-	-	-	LM_I_OL	LM_I_OT	LM_I_OD	LM_ACK_ER	LM_ACK_G	-	-	-	-	-	LM_O_CL	<table border="1"> <tr> <td>LM_E_G</td><td>LM_E_ER</td><td>LM_E_SM2</td><td>LM_E_SM1</td><td>-</td><td>LM_I_UK</td><td>LM_I_SK</td><td>LM_D_RUN</td> </tr> <tr> <td>-</td><td>-</td><td>-</td><td>-</td><td>-</td><td>LM_I_OL</td><td>LM_I_OT</td><td>LM_I_OD</td> </tr> <tr> <td colspan="8">Diagnosebyte mit Fehlercodes optional steckbar Diagnostic byte with error codes (optional pluggable)</td> </tr> <tr> <td>LM_ACK_ER</td><td>LM_ACK_G</td><td>-</td><td>-</td><td>-</td><td>-</td><td>-</td><td>LM_O_CL</td> </tr> </table>	LM_E_G	LM_E_ER	LM_E_SM2	LM_E_SM1	-	LM_I_UK	LM_I_SK	LM_D_RUN	-	-	-	-	-	LM_I_OL	LM_I_OT	LM_I_OD	Diagnosebyte mit Fehlercodes optional steckbar Diagnostic byte with error codes (optional pluggable)								LM_ACK_ER	LM_ACK_G	-	-	-	-	-	LM_O_CL
LM_E_G	LM_E_ER	LM_E_SM2	LM_E_SM1	-	LM_I_UK	LM_I_SK	LM_D_RUN																																																		
-	-	-	-	-	LM_I_OL	LM_I_OT	LM_I_OD																																																		
LM_ACK_ER	LM_ACK_G	-	-	-	-	-	LM_O_CL																																																		
LM_E_G	LM_E_ER	LM_E_SM2	LM_E_SM1	-	LM_I_UK	LM_I_SK	LM_D_RUN																																																		
-	-	-	-	-	LM_I_OL	LM_I_OT	LM_I_OD																																																		
Diagnosebyte mit Fehlercodes optional steckbar Diagnostic byte with error codes (optional pluggable)																																																									
LM_ACK_ER	LM_ACK_G	-	-	-	-	-	LM_O_CL																																																		

Input/output	Bit identifier	Meaning	Condition for setting	Condition for resetting
Input	LM_D_RUN	Diagnostics run mode	Device in operation	Device is not supplying any data
	LM_I_SK	Non-safe input Door and bolt position	Door closed and bolt tongue inserted into interlocking/locking module	Door open OR error in transponder
	LM_I_UK	Non-safe input Guard lock monitoring	Door closed AND locked	Guard locking open OR error in guard locking
	LM_E_SM1	Error status bit for submodule 1	Error in submodule	Automatic if error rectified
	LM_E_SM2	Error status bit for submodule 2	Error in submodule	Automatic if error rectified
	LM_E_ER	Error status bit for escape release	Actuation of the escape release This behavior must be set in the parameters.	Acknowledgment bit LM_ACK_ER is set for min. 50 ms
	LM_E_G	Error status bit General module error	Error in module OR a submodule installed	Automatic if error rectified OR acknowledgment bit LM_ACK_G is set for min. 50 ms
	LM_I_OD	Non-safe input Door position	Door closed	Door open
	LM_I_OT	Non-safe input Bolt tongue	Bolt tongue inserted into interlocking/locking module	Bolt tongue not inserted into interlocking/locking module
	LM_I_OL	Non-safe input Guard locking	Guard locking active	Guard locking released
Output	LM_O_CL	Non-safe control of guard locking	Can be used as additional, non-safe control bit for guard locking. This behavior must be set in the parameters. Control via PLC Bits LM_FO_CL AND LM_O_CL set = guard locking released Bit LM_FO_CL OR LM_O_CL not set = guard locking active	
	LM_ACK_ER	Acknowledgment bit for escape release error	Control via PLC Resets error bit LM_E_ER. Acknowledgment bit must be set for 500 ms (min. 350 ms and max. 750 ms).	
	LM_ACK_G	Acknowledgment bit for general errors	Control via PLC Resets error bit LM_E_G. Acknowledgment bit must be set for 500 ms (min. 350 ms and max. 750 ms).	

### 12.3. Data blocks for expansion module MCM

Expansion modules can contain up to four submodules and evaluate them. They do not have any further dedicated function.

#### 12.3.1. Safe bits

Expansion modules do not have any dedicated safe bits.

#### 12.3.2. Non-safe bits

Standard configuration (basic)		Extended configuration with additional diagnostics byte						
EM_ E_G	EM_ E_SM4	EM_ E_SM3	EM_ E_SM2	EM_ E_SM1	-	-	EM_ D_RUN	IN
EM_ ACK_G	-	-	-	-	-	-	-	OUT
Diagnosebyte mit Fehlercodes optional steckbar Diagnostic byte with error codes (optional pluggable)								IN
EM_ ACK_G	-	-	-	-	-	-	-	OUT

Standard configuration with stacklight (basic)		Extended configuration with stack light and additional diagnostics byte						
EM_ E_G	EM_ E_SM4	EM_ E_SM3	EM_ E_SM2	EM_ E_SM1	-	-	EM_ D_RUN	IN
EM_ ACK_G	-	-	-	-	-	-	-	OUT
EM_ O_H4_B	EM_ O_H4_B	EM_ O_H4_B	EM_ O_H4_B	EM_ O_H4	EM_ O_H3	EM_ O_H2	EM_ O_H1	OUT
Diagnosebyte mit Fehlercodes optional steckbar Diagnostic byte with error codes (optional pluggable)								IN
EM_ ACK_G	-	-	-	-	-	-	-	OUT
EM_ O_H4_B	EM_ O_H4_B	EM_ O_H4_B	EM_ O_H4_B	EM_ O_H4	EM_ O_H3	EM_ O_H2	EM_ O_H1	OUT

Input/output	Bit identifier	Meaning	Condition for setting	Condition for resetting
Input	EM_D_RUN	Diagnostics run mode	Device in operation	Device is not supplying any data
	EM_E_SM1	Error status bit for submodule 1	Error in submodule	Automatic if error rectified
	EM_E_SM2	Error status bit for submodule 2	Error in submodule	Automatic if error rectified
	EM_E_SM3	Error status bit for submodule 3	Error in submodule	Automatic if error rectified
	EM_E_SM4	Error status bit for submodule 4	Error in submodule	Automatic if error rectified
	EM_E_G	Error status bit General module error	Error in module OR a submodule installed	Automatic if error rectified OR acknowledgment bit BM.ACK_G is set for 500 ms (min. 350 ms and max. 750 ms)
Output	EM_ACK_G	Acknowledgment bit for general errors	Control via PLC Resets error bit EM_E_G. Acknowledgment bit must be set for 500 ms (min. 350 ms and max. 750 ms).	
	EM_O_H1	Lamp H1	Only for configurations with stacklight. Control bit for lamp H1...H4. Control via PLC (HIGH = illuminated).	
	EM_O_H2	Lamp H2		
	EM_O_H3	Lamp H3		
	EM_O_H4	Lamp H4		
	EM_O_H1_B	Lamp H1 flashing function	Only for configurations with stacklight. Control bit for lamp H1...H4 flashing function. Control via PLC must be used in combination with the corresponding control bit for the lamp (EM_O_H.). Switching logic based on the example of H1: EM_O_H1 AND EM_O_H1_B = H1 flashes To set the flashing frequency, see chapter 11.8.2. List of the parameters that can be set per module/submodule on page 33.	
	EM_O_H2_B	Lamp H2 flashing function		
	EM_O_H3_B	Lamp H3 flashing function		
EM_O_H4_B	Lamp H4 flashing function			

## 12.4. Data blocks for submodules

For the data blocks your submodule contains, refer to the associated data sheet. See also chapter 11.3. *Information on the related data sheets.*

## 12.5. Replacing a bus module MBM without programming device

If servicing is required, the bus module MBM is easy to replace with a new module. For this purpose, the following prerequisites must be met:

- The DIP switch settings (PROFIsafe address) on the new device must match those on the old device.
- Your PROFINET master must support the automatic replacement of PROFINET devices.
- Your PROFINET topology must be correctly configured.
- The replacement device must be connected to the same port as its predecessor.
- There must be no device name in the bus module.  
This field is empty in the delivery state. MBMs that already contain a name must first be reset to the factory settings.

Once these conditions are met, simply replace the old MBM with the new MBM.

## 12.6. Handle module teach-in operation (only for systems with locking module MGB2 uni-code)

The handle module must be assigned to the locking module using a teach-in function before the system comprising locking module and handle module forms a functional unit.

You will find a detailed description of the teach-in operation in the operating instructions for your locking/interlocking module.

## 13. Diagnostics, troubleshooting and aids

All error codes are listed in the following. If you use the data blocks with **extended configuration** in the configuration software for your control system, the error code is output in the corresponding byte. In the **standard configuration**, only a corresponding error status bit is set and the system indicates the error via the diagnostics LEDs.



### Important!

The error code given in the tables below is sequential and starts with 0x01. You must add any upstream error codes from PROFINET or the control system to the error codes stated. For PROFINET, the offset to be taken into account is 0x100.

Most messages are also displayed on the devices.

<b>Key to symbols</b>	○		LED not illuminated
			LED illuminated
	3 x		LED flashes three times
	1 Hz		LED flashes at 1 Hz
	long on		LED flashes with a long turn-on time

### 13.1. Reset and restart

To acknowledge general errors and restart the system, disconnect the bus module MBM from the power supply for a few seconds.

### 13.2. Acknowledging errors

To acknowledge errors, set the respective acknowledgment bit for 500 ms (min. 350 ms and max. 750 ms). You will find an overview of the error messages and reset conditions from chapter 13.5. *General errors*.

### 13.3. Resetting system to factory settings (factory reset)

You can reset the device using one of the following methods:

- › With the aid of the configuration software for your control system (this resets only the PROFINET portion).  
Example for Siemens TIA-Portal: in the “Online & Diagnostics” dialog box
- › With the aid of the DIP switches in the bus module MBM (this resets the overall system including the MLI topology).  
Procedure: Switch off system, set “RST” DIP switch to “ON” position and restart system. If DIA and MAINT flash alternately, switch the system off, set the “RST” DIP switch to “OFF” position and restart the system.  
See also chapter 9.1. *DIP switches on page 16*.
- › Check the safe function of the safeguard and, if necessary, other safety functions after every factory reset.



## 13.4. Diagnostics with the aid of the device web interface

The device has an internal device web interface. The device web interface can be used at any time in operation if the function is activated. It is not possible to make any settings on the device.

The following diagnostics information is provided:

- Overview of all modules and submodules installed
- Status and version of all modules and submodules installed
- IP address and device name of the bus module MBM
- PROFIsafe address
- Error list for each module and submodule
- Error list for the overall system

The error numbers indicated correspond to those in the error tables below from chapter 13.5 on page 43.

### 13.4.1. Using device web interface

Proceed as follows:

1. Set “WWW” DIP switch to “on” position. See also chapter 9.1 on page 16.  
Notice: The change is effective only after a restart.
  2. Connect device to a PC or other suitable input/output device using a network cable.
  3. Open the device web interface in the browser (IP address: XXX.XXX.XXX.XXX).
- ➔ The HOME page appears.

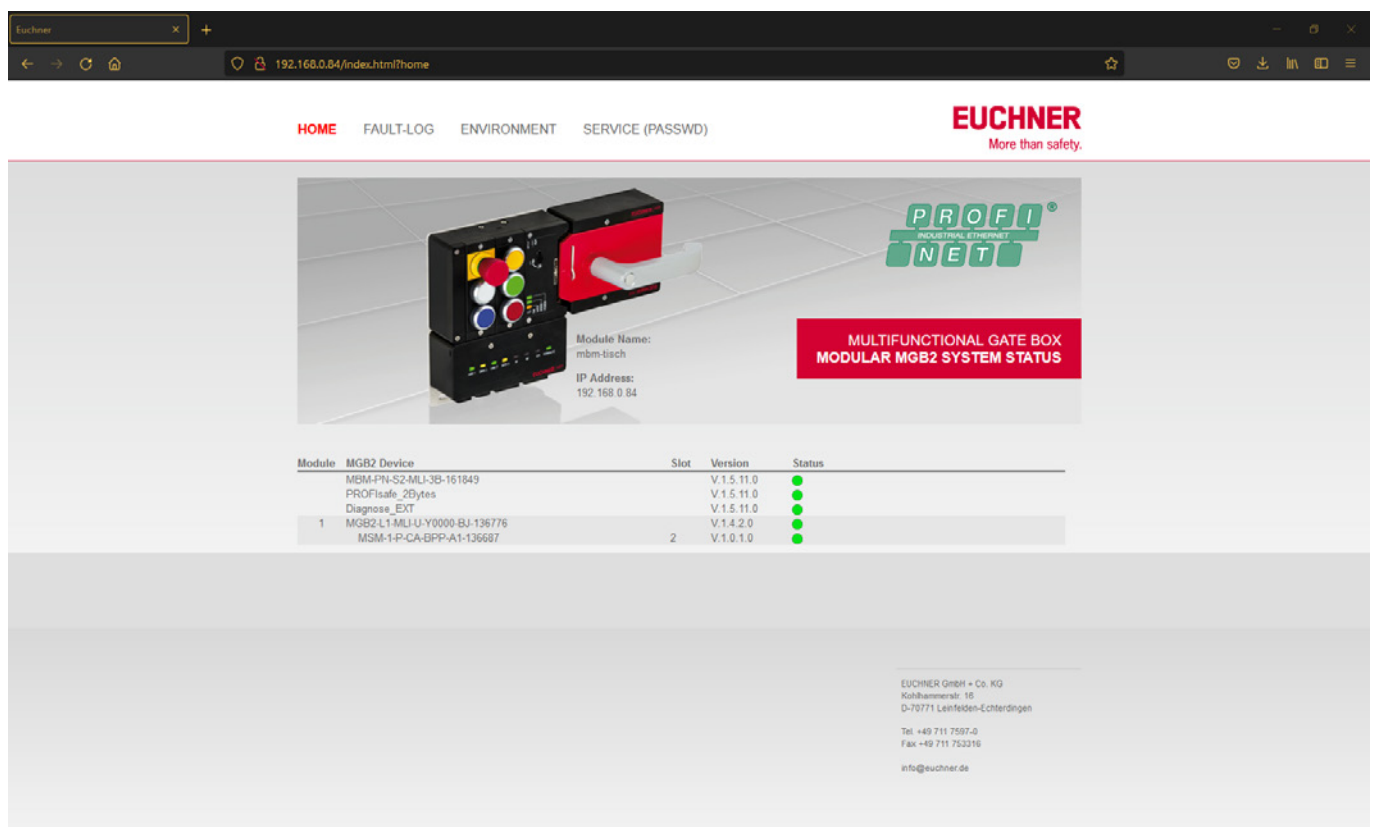

Fig. 7: HOME page on the device web interface in the bus module MBM

There you can see information on the bus module MBM and on the modules and submodules connected. Devices with errors have a red status.

On the HOME page, you can do the following:

- Click the name of a module to open the diagnostics page for the module.
- Click FAULT-LOG to display a fault log for the overall system. All current and previous errors since setup are listed there. The error list can also be downloaded from the device. With this file, our support team will be able to provide specific assistance if you have problems. The download link is at the end of the error list. Click ENVIRONMENT to display available environment parameters.
- Click Settings to download the HTTPS certificate. The administrator area with firmware update option can also be found here. This can be protected by a user-assigned password.

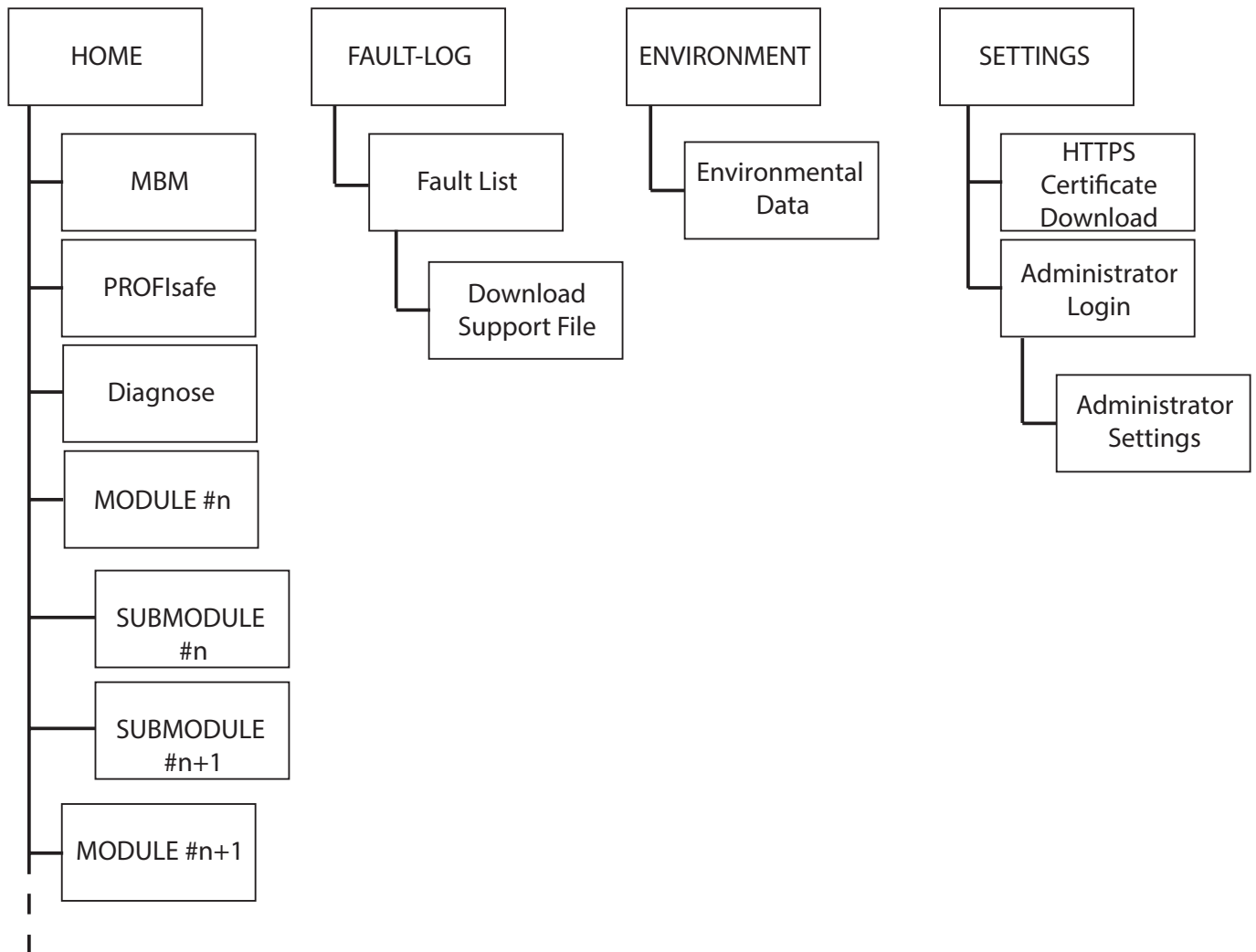

Fig. 8: Site map for the device web interface in the bus module MBM

### 13.4.2. Using password



**Important!**

- EUCHNER recommends assigning an individual password for each device.
- If a default password is used for different devices instead of individual passwords, it is essential to observe the following points:
  - The use of default passwords might facilitate unauthorized access to the network and the devices.
  - If a network error occurs during the firmware update process, devices not intended for a firmware update might be updated.

## 13.5. General errors

### MBM

Error code	Error designation	Meaning	Error category	Error behavior	Troubleshooting	Corresponding error/status bit	LED displays							
							Bus module							
							LINK 1 / LINK 2	ACT 1 / ACT 2	SF	BF	DIA	US1	MAINT	PS
0x01 ... 0x06	Internal fault	Internal device fault. Device is no longer functional.	Internal fault	Latching	Restart system. If the error persists, contact our support team.	BM_E_G	○	○	○	○	☀	☀	○	○

### Interlocking/locking module

Error code	Error designation	Meaning	Error category	Error behavior	Troubleshooting	Corresponding error/status bit	LED displays					
							Interlocking/locking module					
							POWER	STATE	LOCK	DIA	SLOT 1	SLOT 2
0x01 ... 0x06	Internal fault	Internal device fault. Device is no longer functional.	Internal fault	Latching	Restart system. If the error persists, contact our support team.	LM_E_G	☀	○	○	☀	○	○

### MCM

Error code	Error designation	Meaning	Error category	Error behavior	Troubleshooting	Corresponding error/status bit	LED displays				
							Interlocking/locking module				
							POWER/FC	STATE	DIA	SLOT RED	SLOT GREEN
0x01 ... 0x06	Internal fault	Internal device fault. Device is no longer functional.	Internal fault	Latching	Restart system. If the error persists, contact our support team.	EM_E_SM	☀	○	☀	○	○

### 13.6. Teach-in errors and configuration errors

#### MBM

Error code	Error designation	Meaning	Error category	Error behavior	Troubleshooting	Corresponding error/status bit	LED displays							
							Bus module							
							LINK 1 / LINK 2	ACT 1 / ACT 2	SF	BF	DIA	US1	MAINT	PS
OxAE	Configuration error	Configuration in the control system does not match the actual configuration. Modules might be swapped or in the wrong location.	Configuration error	Latching	Restore the correct configuration and restart the system. A factory reset may be necessary.	BM_E_G								
OxEA	Topology error	Saved topology does not match the actual topology. Modules might be swapped or in the wrong location.	Topology error	Latching	Restore the correct topology and restart the system. An intentional change of the MLI topology must be reset via factory reset.	BM_E_G								
OxEB	Topology error	Saved topology does not match the actual topology. Modules might have been added or removed.	Topology error	Latching	Restore the correct topology and restart the system. An intentional change of the MLI topology must be reset via factory reset.									

#### Interlocking/locking module

Error code	Error designation	Meaning	Error category	Error behavior	Troubleshooting	Corresponding error/status bit	LED displays					
							Interlocking/locking module					
							POWER	STATE	LOCK	DIA	SLOT 1	SLOT 2
Ox1F	Actuator/handle module could not be taught-in	Actuator/handle module not detected often enough during teach-in operation or removed during teach-in operation	Teach-in error	Latching	Restart teach-in operation. Make sure the handle module is not removed during the teach-in operation. (Door closed, bolt tongue inserted.)	LM_E_G						
Ox22	Solenoid configuration error	Single-channel solenoid control	Configuration error	Latching	Set solenoid monitoring in the settings							

## 13.7. Transponder errors





Error code	Error designation	Meaning	Error category	Error behavior	Troubleshooting	Corresponding error/status bit	LED displays Interlocking/ locking module					
							POWER	STATE	LOCK	DIA	SLOT 1	SLOT 2
0x42	Invalid handle module detected	Handle module is not valid or handle module is faulty.	Transponder error	Latching	Restart teach-in operation. If the error persists, contact our support team.	LM_E_G		3x				
0x25	Disabled actuator detected	Already taught-in but disabled actuator has been detected.	Transponder error	Latching	Repeat teach-in operation with a new handle module or use taught-in handle module if a teach-in operation was not intended.	LM_E_G		3x				

## 13.8. Environment errors



### MBM

Error code	Error designation	Meaning	Error category	Error behavior	Troubleshooting	Corresponding error/status bit	LED displays Bus module								
							LINK 1 / LINK 2	ACT 1 / ACT 2	SF	BF	DIA	US1	MAINT	PS	
0x60	Supply voltage too high	Overvoltage	Environment error	Resettable/latching	Decrease supply voltage. Pay attention to technical data.	BM_E_G									
0x61	Supply voltage too low	Low voltage	Environment error	Resettable	Increase supply voltage or check system topology. Pay attention to technical data and max. number of modules/submodules. Possibly excessively long cables.						long on		5x rd		

**Interlocking/locking module**

Error code	Error designation	Meaning	Error category	Error behavior	Troubleshooting	Corresponding error/status bit	LED displays Interlocking/ locking module						
							POWER	STATE	LOCK	DIA	SLOT 1	SLOT 2	
<b>0x60</b>	Supply voltage too high	Overvoltage	Environment error	Resettable	Decrease supply voltage. Pay attention to technical data.	LM_E_G			5x				
<b>0x61</b>	Supply voltage too low	Low voltage	Environment error	Resettable	Increase supply voltage or check system topology. Pay attention to technical data and max. number of modules/submodules. Possibly excessively long cables.								
<b>0x62</b>	Temperature too high	Temperature in the housing too high	Environment error	Latching	Check whether the system is operating in the temperature range specified. Pay attention to technical data.								
<b>0x63</b>	Temperature too low	Temperature in the housing too low	Environment error	Latching	Check whether the system is operating in the temperature range specified. Pay attention to technical data.								

**MCM**

Error code	Error designation	Meaning	Error category	Error behavior	Troubleshooting	Corresponding error/status bit	LED displays Interlocking/ locking module						
							POWER/FC	STATE	DIA	SLOT RED	SLOT GREEN		
<b>0x60</b>	Supply voltage too high	Overvoltage	Environment error	Resettable	Decrease supply voltage. Pay attention to technical data.	EM_E_SM			5x				
<b>0x61</b>	Supply voltage too low	Low voltage	Environment error	Resettable	Increase supply voltage or check system topology. Pay attention to technical data and max. number of modules/submodules. Possibly excessively long cables.								
<b>0x62</b>	Temperature too high	Temperature in the housing too high	Environment error	Latching	Check whether the system is operating in the temperature range specified. Pay attention to technical data.								
<b>0x63</b>	Temperature too low	Temperature in the housing too low	Environment error	Latching	Check whether the system is operating in the temperature range specified. Pay attention to technical data.								

## 13.9. Communication errors



### MBM

Error code	Error designation	Meaning	Error category	Error behavior	Troubleshooting	Corresponding error/status bit	LED displays							
							Bus module							
							LINK 1 / LINK 2	ACT 1 / ACT 2	SF	BF	DIA	US1	MAINT	PS
0x74	MLI1 disrupted	Communication disrupted	Communication error	Resettable	Check cables and plug connectors for correct seating and damage.	BM_E_G								
0x75	MLI2 disrupted	Communication disrupted	Communication error	Resettable	Check cables and plug connectors for correct seating and damage.									
0x78	Safety communication with devices lost	Communication disrupted	Communication error	Resettable	Check cables and plug connectors for correct seating and damage.									
0x79	Non-safety communication with devices lost	Communication disrupted	Communication error	Resettable	Check cables and plug connectors for correct seating and damage.									4x rd
0x7A	Maximum number of modules/submodules exceeded		Communication error	Latching	Reduce the number of modules/submodules in your system. Max. 18 devices									
0x7B	Bus open circuit error	No Link signal; Ethernet cable is not connected	Communication error	Resettable	Check PROFINET connection	BM_E_G								



### Interlocking/locking module

Error code	Error designation	Meaning	Error category	Error behavior	Troubleshooting	Corresponding error/status bit	LED displays						
							Interlocking/locking module						
							POWER	STATE	LOCK	DIA	SLOT 1	SLOT 2	
0x74	MLI1 disrupted	Communication disrupted	Communication error	Resettable	Check cables and plug connectors for correct seating and damage.	LM_E_G							

**MCM**

Error code	Error designation	Meaning	Error category	Error behavior	Troubleshooting	Corresponding error/status bit	LED displays Interlocking/ locking module				
							POWER/FC	STATE	DIA	SLOT RED	SLOT GREEN
0x74	MLI1 disrupted	Communication disrupted	Communication error	Resettable	Check cables and plug connectors for correct seating and damage.	EM_E_SM	 1x	○			

**13.10. Plausibility errors**

Error code	Error designation	Meaning	Error category	Error behavior	Troubleshooting	Corresponding error/status bit	LED displays Interlocking/ locking module			
							POWER	STATE	DIA	LOCK
0x88	Plausibility error: bolt fracture	Transponder for the bolt has been detected without the door closed.	Plausibility error	Resettable	Check function of the handle module. Pay attention to damage. Replace handle module if necessary. Acknowledge error with LM_ACK_G.	LM_E_G				
0x8A	Plausibility error: signal sequence	Transponder was detected or removed without the bolt handle having been moved. Door may have been slammed too fast.	Plausibility error	Resettable	Open door, acknowledge fault with LM_ACK_G. Close door more slowly. On repeated occurrence, contact our support team.			○		 1x
	Escape release	Message that the escape release has been actuated (only if set in the parameters)	Plausibility error	Resettable	Rectify error via general acknowledgment bit LM_ACK_G or via acknowledgment bit LM_ACK_ER for escape release error.	LM_E_G/ LM_E_ER				



## 13.11. Submodule errors





Error code	Error designation	Meaning	Error category	Error behavior	Troubleshooting/ acknowledgment	LED displays	
						Submodule	
						SLOT RED	SLOT GREEN
	Incorrect submodule	Submodule type detected does not correspond to the submodule type saved	Incorrect submodule	Submodule will be ignored; no effect on overall system	Replace submodule, modify system topology or restart system		 3x
	Submodule missing	Submodule missing, even though a submodule has been taught-in for the slot	Submodule missing	Missing submodule will be ignored; no effect on overall system	Install submodule or modify system topology		 1x
	Submodule rotated by 180°	Submodule is installed rotated by 180°	Submodule rotated by 180°	Submodule will be ignored; no effect on overall system	Rotate submodule by 180°		 2x
	Internal submodule fault	Internal device fault. Submodule is no longer functional.	Internal submodule fault	Submodule will be ignored; no effect on overall system	Replace submodule		○
<b>OxA0</b>	Error in the safety equipment (can be reset automatically)	E.g.: discrepancy error (emergency stop, enabling switch, key-operated rotary switch, acknowledgment pushbutton)	Safety error in submodule	Latching	For submodules to which an external device is connected (e.g. enabling switch): check correct function of the external device. For errors in the submodule: replace faulty submodule and send to the manufacturer.	 1 Hz	○

## 13.12. PROFINET errors

Error code	Error designation	Meaning	Error category	Error behavior	Troubleshooting	Corresponding error/status bit	LED displays							
							Bus module							
							LINK 1 / LINK 2	ACT 1 / ACT 2	SF	BF	DIA	US1	MAINT	PS
<b>Ox10C</b>	Parameter setting error	The assembly has detected a parameter setting error. Parameter setting errors can be: - The assembly cannot evaluate any parameters (examples of possible causes: unknown parameters, invalid parameter combination). - No parameters have been assigned yet to the assembly.	Application error	Latching	Check parameters and correct these. Then load the parameters into the assembly again.								 2x rd	

### 13.13. PROFI-safe errors

Error code	Error designation	Meaning	Error category	Error behavior	Troubleshooting	Corresponding error/status bit	LED displays									
							Bus module									
							LINK 1 / LINK 2	ACT 1 / ACT 2	SF	BF	DIA	US1	MAINT	PS		
<b>0x0150</b>	F_DEST_ADDR	Erroneous safety destination address	Parameter setting error	Latching	The PROFI-safe address set on the device does not match the address set in the configuration tool for your control system. Either modify the DIP switch setting or change the information in the parameter F_dest_adr.											
<b>0x0151</b>	F_DEST_ADDR	Safety destination address invalid	Parameter setting error	Latching	The PROFI-safe address set in the configuration tool for your control system has an impermissible value. Check the parameter setting.											
<b>0x0152</b>	F_SOURCE_ADDR	Safety source address invalid	Parameter setting error	Latching	The PROFI-safe source address set in the configuration tool for your control system has an impermissible value. Check the parameter setting.											
<b>0x0153</b>	F_WD_TIME	Watchdog timer value is 0 ms	Parameter setting error	Resettable	The value for the watchdog timer set in the configuration tool for your control system has an impermissible value. Check the parameter setting.											
<b>0x0154</b>	F_SIL	Parameter F_SIL exceeds SIL for the specific device application	Parameter setting error	Resettable	The value for F_SIL set in the configuration tool for your control system has an incorrect value. Check the parameter setting.	BM_E_G	☀	○	○	☀	☀	○	☀ 1x			
<b>0x0155</b>	F_CRC_Length	Parameter F_CRC_LENGTH does not correspond to the values generated			The value for the length of the CRC set in the configuration tool for your control system has an incorrect value. Check the parameter setting.											
<b>0x0156</b>	F_Version	Version for F parameter set incorrectly	Parameter setting error	Resettable	An incorrect version or an invalid F_Version has been detected. Check the parameter setting.											
<b>0x0157</b>	F_CRC1	CRC1 error	Parameter setting error	Resettable	The CRC value calculated does not match the value in the GSDML file. There may be an incorrect value in the GSDML file or incorrect transmission due to interference (e.g. EMC problems).											
<b>0x0158</b>	Device specific diagnosis information	Device-specific error			Information that a device-specific error has occurred. See error codes from chapter 13.5. General errors on page 39ff.											
<b>0x0159</b>		Watchdog Time iParameter saving exceeded														

Error code	Error designation	Meaning	Error category	Error behavior	Troubleshooting	Corresponding error/status bit	LED displays									
							Bus module									
							LINK 1 / LINK 2	ACT 1 / ACT 2	SF	BF	DIA	US1	MAINT	PS		
<b>0x0162</b>		F_Block_ID not supported	Parameter setting error	Resettable	Check the parameters and correct them. Then load the parameters into the assembly again.											
<b>0x0163</b>	CRC2 error		Communication error	Resettable	Read the CRC2 error memory. Restart communication.	BM_E_G			○	○			○		1x	
<b>0x0164</b>	F_WD_Time or F_WD_Timer_2 elapsed	Transfer error: timeout	Communication error	Resettable	Restart communication.											

## 14. Updating firmware

The device's firmware can be updated using the EUCHNER Device Update tool. You will find further information in the software manual.



### WARNING

Loss of the safety function

A firmware update can change or expand functions.

Observe the following points to ensure the safety function:

- › Carefully observe the release notes for the respective firmware version prior to the update process. Ensure that the changes the firmware update triggers in the device continue to comply with the requirements of the overall system.
  - Perform a risk assessment on the overall system before the update if necessary, because the update could change functions or processes in the EUCHNER device.
  - Observe and follow the instructions in the software manual when updating the firmware.

### 14.1. Running EUCHNER Device Update



### NOTICE

Damage to the device

The device can be damaged when the firmware is updated.

- › Make sure to use only one instance of the EUCHNER Device Update tool. Sending several broadcasts simultaneously from different instances to search for devices can damage the device.
- › Ensure that a possible network connection loss does not result in losing data and damaging the device. While scanning the network, an overload might occur.
- › Ensure a stable power supply for the device.
- › Ensure that the automatic restart of the device after a successful update is not interrupted.



### Important!

- › After the update, check the update report to determine whether and on which devices the update process was successful.
- › Ensure that the firmware update is recorded in the machine documentation using the automatically generated update report.
- › Ensure that the device documentation corresponding to the update is available and is observed after the device update.

### 15. Technical data



#### NOTICE

If a data sheet is included with the product, the information on the data sheet applies.

Parameter	Value
Housing material	Fiber glass reinforced plastic Die-cast zinc, nickel-plated, stainless steel
Dimensions	See dimension drawing
Weight, bus module	0.8 kg
Ambient temperature	-25 ... +55 °C at UB = 24 V
Degree of protection	IP65
Safety class	III
Degree of contamination	3
Installation position	Any
Connection options, power supply <sup>1)</sup>	2 x push-pull power or 2 x plug connectors 7/8" acc. to ANSI/B93.55M-1981 or 2 x M12 plugs (L-coded), 5-pin, acc. to IEC 61076-2-101 or 2 x M12 plugs (L-coded), 4-pin, acc. to IEC 61076-2-101
Connection, bus <sup>1)</sup>	2 x RJ 45, push-pull, acc. to IEC 61076-3-117, variant 14, screened or 2 x M12 (D-coded) according to IEC 61076-2-101
Connecting cable, bus	PROFINET I/O cable, at least cat. 5e
Operating voltage U <sub>B</sub>	DC 24 V +20%/-15% (PELV – see chapter 10. Electrical connection)
Current consumption, max. (only bus module)	200 mA
Current consumption, max. (bus module and all connected modules/submodules)	
- Push-pull plug connector/plug connector 7/8" according to ANSI/B93.55M-1981	4 A
- Plug connector M12 (L-coded) <sup>2)</sup>	3.2 A
Maximum feed-in current in the connection block	
- Push-pull plug connector	16 A
- Plug connector M12 (L-coded) <sup>2)</sup>	12 A
- Plug connector 7/8" acc. to ANSI/B93.55M-1981	6 A
Fuse protection for power supply, external	Min. 4 A slow-blow
Safety outputs	PROFIsafe acc. to IEC 61784-3-3
Rated insulation voltage U <sub>i</sub>	75 V
Rated impulse withstand voltage U <sub>imp</sub>	0.5 kV
Resilience to vibration and shock	Acc. to EN 60947-5-3
EMC protection requirements	Acc. to EN 61000-4 and DIN EN 61000-6-7
Risk times, max. (turn-off times) <sup>3)</sup>	
Overall system:	200 ms
Fixed value for the processing of safety functions such as	
- Evaluation of submodules with emergency stop, safe pushbuttons or switches, enabling switches, etc.	
- Monitoring of the position of the guard.	
- Monitoring of guard locking.	
<b>Characteristics acc. to EN ISO 13849-1 / EN IEC 62061</b>	
Category	4
Safety Integrity Level	SIL 3
Performance Level	PL e
DC	99%
Mission time	20 years
PFH <sup>4)</sup>	5.38 x 10 <sup>-9</sup>

1) The document *PROFINET Cabling and Interconnection Technology* from the PNO aids in the correct selection of cables.

2) At temperatures < 40 °C, the max. current consumption (bus module including all connected modules/submodules) can be increased to 4 A and the max. feed-in current in the connection block to 16 A.

3) The risk time is the maximum time between the change in an input status and the clearing of the corresponding bit in the bus protocol. See chapter *Calculation example for determining the risk time for safe functions* on page 54.

4) Information regarding wearing parts without consideration of fixed failure rates in electronic components.

## Calculation example for determining the risk time for safe functions



### Important!

The values in this calculation are only examples. Please refer to the operating instructions of the respective device for the values.

Only modules and submodules that contain a safety function flow into the calculation of the risk time. Safe modules and submodules are apparent because they transmit safe bits (PROFIsafe bits) via the bus module to the control system.

Modules with safety functions are, for example:

- › Interlocking and locking modules MGB2-I.../MGB2-L...
- › Submodules MSM with emergency stop, safe acknowledgment pushbutton, safe selector switch, enabling switch, etc.

The following formula applies to the calculation of the risk time for your system:

$$T_{\text{Risk}} = T_{\text{RiskSystem}} + T_{\text{RiskFunction}}$$

$$T_{\text{RiskSystem}} = T_{\text{P}} + n \times t_{\text{L}}$$

- $T_{\text{Risk}}$  = Total risk time of a safety function  
 $T_{\text{P}}$  = Processing time for safety function (general figure 200 ms)  
 $t_{\text{L}}$  = Latency time for a safe module/submodule (general figure 27 ms)  
 $n$  = Number of safe modules/submodules installed in the system  
 $T_{\text{RiskFunctionSK}}$  = 90 ms  
 $T_{\text{RiskFunctionUK}}$  = 70 ms  
 $T_{\text{RiskFunctionElements}}$  = 35 ms (valid for all safe functions except SK and UK)

The following example shows a system with three locking modules. In two of the locking modules, there is one submodule with a safety function installed. There is therefore a total of 5 safe modules/submodules.

System layout	Position	Module/submodule	Safety function?	Processing time $T_{\text{P}}$	Latency time $t_{\text{L}}$
	1	Bus module MBM	-	200 ms	-
	2	Locking module MGB2-L	Yes	-	27 ms
	3	Locking module MGB2-L	Yes	-	27 ms
	4	Submodule MSM with emergency stop safety function	Yes	-	27 ms
	5	Interlocking module MGB2-I	Yes	-	27 ms
	6	Submodule MSM	No	-	-
	7	Submodule MSM with emergency stop safety function	Yes	-	27 ms

These data yield the following calculation:

$$T_{\text{RiskSystem}} = 200 \text{ ms} + 5 \times 27 \text{ ms} = 335 \text{ ms}$$

$$T_{\text{RiskSK}} = 335 \text{ ms} + 90 \text{ ms} = 425 \text{ ms}$$

$$T_{\text{RiskUK}} = 335 \text{ ms} + 70 \text{ ms} = 405 \text{ ms}$$

$$T_{\text{RiskElements}} = 335 \text{ ms} + 35 \text{ ms} = 370 \text{ ms}$$

## 16. Service

If servicing is required, please contact:

EUCHNER GmbH + Co. KG  
Kohlhammerstraße 16  
70771 Leinfelden-Echterdingen  
Germany

**Service telephone:**

+49 711 7597-500

**E-mail:**

support@euchner.de

**Internet:**

www.euchner.com

## 17. Inspection and service



**WARNING**

Loss of the safety function because of damage to the device.  
In case of damage, the affected module must be replaced completely. Only accessories or spare parts that can be ordered from EUCHNER may be replaced.

Regular inspection of the following is necessary to ensure trouble-free long-term operation:

- › Check the secure mounting of the devices and the connections

Further inspection measures may be necessary for the modules connected and submodules installed. Refer to the related operating instructions.

No servicing is required. Repairs to the device are only allowed to be made by the manufacturer.



**NOTICE**

The year of manufacture can be seen in the lower right corner of the type label.

## 18. Declaration of conformity

The product complies with the requirements according to Machinery Directive 2006/42/EC.

The EU declaration of conformity can be found at [www.euchner.com](http://www.euchner.com). Enter the order number of your device in the search box. The document is available under *Downloads*.

EUCHNER GmbH + Co. KG  
Kohlhammerstraße 16  
70771 Leinfelden-Echterdingen  
Germany  
info@euchner.de  
www.euchner.com

Edition:  
MAN20001743-01-07/24  
Title:  
Operating Instructions Bus Module  
MBM-PN-.-MLF... (PROFINET)  
(translation of the original operating instructions)  
Copyright:  
© EUCHNER GmbH + Co. KG, 07/2024

Subject to technical modifications;  
no responsibility is accepted for the accuracy of this information.