

## Scope

These operating instructions are valid for all evaluation units CMS-E-ER... These operating instructions, the operating instructions for read heads CMS-R... and actuator CMS-M, the document *Safety information* and any available data sheet form the complete user information for your device.

### Important!

Make sure to use the operating instructions valid for your product version. The version numbers can be found on the type label of your product. Please contact the EUCHNER service team if you have any questions.

## Evaluation unit type label

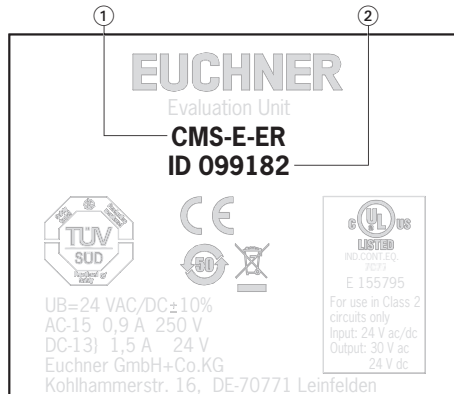

- ① Item designation
- ② Item number

## Supplementary documents

The overall documentation for this device consists of the following documents:

Document title (document number)	Contents	
Safety information (2525460)	Basic safety information	
Operating instructions (2102344)	(this document)	
Operating instructions (2085673)	Read heads/actuators for evaluation units CMS	
Operating instructions (2102384)	Read heads/actuators for evaluation units CMS	
Operating instructions (2113226)	Read heads/actuators with Hall sensors for evaluation units CMS	
Declaration of conformity	Declaration of conformity	
Any additions to the operating instructions	Take any associated additions to the operating instructions or data sheets into account.	

### Important!

Always read all documents to gain a complete overview of safe installation, setup and use of the device. The documents can be downloaded from [www.euchner.com](http://www.euchner.com). For this purpose, enter the doc. no. or the order number for the device in the search box.

## Correct use

Evaluation units series **CMS** are technical safety devices for monitoring movable guards. Special read heads are connected for this purpose.

The system consists of evaluation unit, read head and actuator. It forms a non-contact, magnetically coded interlocking device with low coding level (type 4).

In combination with a guard, this system prevents dangerous machine functions from being performed for as long as the guard is opened. A stop command is triggered if the guard is opened during the dangerous machine function.

This means:

- ▶ Starting commands that cause a dangerous machine function must become active only when the guard is closed.

- ▶ Opening the guard triggers a stop command.
- ▶ Closing the guard must not cause automatic starting of a dangerous machine function. A separate start command must be issued. For exceptions, refer to EN ISO 12100 or relevant C-standards.

Before safety components are used, a risk assessment must be performed on the machine, e.g. in accordance with the following standards:

- ▶ EN ISO 13849-1
- ▶ EN ISO 12100
- ▶ EN IEC 62061

Correct use includes observing the relevant requirements for installation and operation, e.g. according to the following standards:

- ▶ EN ISO 13849-1
- ▶ EN ISO 14119
- ▶ EN IEC 60204-1

### Important!

- ▶ The evaluation unit must be used only in conjunction with the designated read heads and actuators from EUCHNER. On the use of different read heads or actuators, EUCHNER provides no warranty for safe function.
- ▶ The devices permit a safety-related stop function, initiated by a guard according to Table 8 – EN ISO 13849-1: 2023.
- ▶ The safety-related function of the safety system is the opening of the output contacts when the actuator is absent.
- ▶ The user is responsible for safe integration of the device into a safe overall system. For this purpose, the overall system must be validated, e.g. in accordance with EN ISO 13849-1.
- ▶ Correct use requires observing the permissible operating parameters (see technical data).
- ▶ If a data sheet is included with the product, the information on the data sheet applies in case of discrepancies with the operating instructions.
- ▶ Only components that are permissible in accordance with the following combination options table may be used. Refer to the operating instructions of the corresponding component for further information.

## Exclusion of liability and warranty

In case of failure to comply with the conditions for correct use stated above, or if the safety regulations are not followed, or if any servicing is not performed as required, liability will be excluded and the warranty void.

## General safety precautions

Safety components fulfill personnel protection functions. Incorrect installation or tampering can lead to severe injuries to personnel.

Check the safe function of the guard particularly

- ▶ after any setup work
- ▶ each time after replacement of a CMS component
- ▶ after an extended period without use
- ▶ after every fault

Independent of these checks, the safe function of the safeguard should be checked at suitable intervals as part of the maintenance schedule.

**Warning!** Danger of fatal injury in the event of incorrect connection or incorrect use.

Safety components must not be bypassed (bridging of contacts), turned away, removed or otherwise rendered ineffective. Pay particular attention to EN ISO 14119: 2025, section 8, regarding the possibilities for bypassing an interlocking device.

The device may be installed and put into operation only by authorized personnel

- ▶ who are familiar with the correct handling of safety components

- ▶ who are familiar with the applicable EMC regulations
- ▶ who are familiar with the applicable regulations on operational safety and accident prevention
- ▶ who have read and understood the operating instructions.

## Function

**The safety system CMS consists of evaluation unit, read head and actuator and is functional only in particular combinations (see combination options).**

Depending on the type of the connected read heads, the evaluation unit CMS-E-ER is used for monitoring one to 30 safety doors or up to 10 safety doors.

The read heads CMS-R... have electrically isolated reed contacts with NC contacts and NO contacts.

The read heads CMS-RH... are based on Hall sensors with electrically isolated outputs with NC contacts and NO contacts.

If the actuator is in the actuating range, the contacts in the read head are switched by the magnetic field. The switching status of the contacts is displayed on the evaluation unit's LEDs (see section LED displays). Due to the NC/NO contact combination in the read head, the evaluation unit expects to receive antivalent signal changes. The evaluation unit converts this information and transfers the guard state to the control system via a safety contact.

If the actuators for all the read heads connected are in the actuating range, safety contacts 13/14 and 23/24 are closed. The additional auxiliary contact 31/32 is opened.

When the safety door is opened or closed, the evaluation unit is checked to ensure that it is functional. In this way, internal errors from the read head to the controlgear output can be detected.

If an error is detected, the evaluation unit changes to a blocked state. The safety contacts remain in the open state.

The auxiliary contact is electrically isolated from the safety contacts.

If contactors are used, the switching contacts can be monitored for a possible malfunction by the evaluation unit via a feedback loop. A start button can also be connected to the evaluation unit. Four connection variants are possible here:

- ▶ Manual start using start button with falling edge and connected feedback loop
- ▶ Manual start using start button with rising edge and connected feedback loop
- ▶ Automatic start with connected feedback loop
- ▶ Automatic start without feedback loop

### Manual start using start button with falling edge and connected feedback loop

In the case of a monitored feedback loop, safety outputs 13/14 and 23/24 are activated only if all connected read heads are in the actuating range, feedback loop Y1/Y2 is closed and the start button is released after actuation.

The safety contacts are closed only when the start button is released. The start pulse is monitored by the system.

### Manual start using start button with rising edge and connected feedback loop

In the case of a monitored feedback loop, safety contacts 13/14 and 23/24 are activated only if all connected read heads are in the actuating range, feedback loop Y1/Y3 is closed and the start button is pressed.

The safety contacts are closed when the start button is pressed. The start pulse is monitored by the system.

## Automatic start with connected feedback loop

If a start button is not to be included in the feedback loop, the feedback loop must be connected to terminals Y1 and Y3. Here too, safety contacts 13/14 and 23/24 are activated only when all connected read heads are in the actuating range and feedback loop Y1/Y3 is closed.

## Automatic start without feedback loop

In case of automatic start without a feedback loop, a 2-pin jumper must be connected to Y1 and Y3.

## Fault detection by the unit

The CMS-E-ER is a self-monitoring system unit. Faults and short circuits in the read head or internal errors in the evaluation unit will be detected and the safety circuit will be safely switched off. Internal linking of the relays in the evaluation unit prevents the machine from starting up in the event of a fault.

## Connection of electromechanical safety switchgear (safety switches, emergency stop, ...)

Unlike evaluation unit CMS-E-BR, evaluation unit CMS-E-ER does not enter the fault state if the contacts do not switch simultaneously when the door is closed. This also permits mechanical safety switches with NC/NO contact combination (e.g. emergency stop switch) to be connected to the evaluation unit CMS-E-ER.

## Connection of CMS read heads

- ▶ Up to 30 read heads with reed contacts or 10 read heads with Hall sensors can be connected to the evaluation unit.
- ▶ If the actuator is moved slowly toward the read head in lateral approach direction **Z**, the evaluation unit changes to the blocked state. To cancel the blocked state, the actuator must again be moved beyond the release distance.

## Mounting

**Caution!** The evaluation unit must be installed in a control cabinet with a minimum degree of protection of IP54. A snap-in element on the rear of the device is used for fastening to a mounting rail. If several evaluation units are mounted side by side in a control cabinet without air circulation (e.g. fan), a minimum distance of 10 mm must be maintained between the evaluation units. This distance enables the heat from the evaluation unit to dissipate.

**Caution!** Risk of damage to equipment as a result of incorrect installation. Read heads or actuators must not be used as a mechanical end stop. Fit an additional end stop for the movable part of the guard.

**Important!** From the assured release distance  $S_{ar}$ , the safety outputs are safely shut down. If the actuator is installed flush, the operating distances change as a function of the installation depth and the guard material.

If the actuator is moved out of the actuating range, it is ensured that safety contacts 13/14 and 23/24 and auxiliary contact 31/32 switch only when the actuator is moved back into operating distance  $s_{a0}$  after having exceeded the release distance (see combination options table).

Note the following points:

Read head and actuator must be easily accessible for inspection and replacement.

The switching operation must be triggered only by the specific actuator designated for this purpose.

Read head and actuator must be fitted so that:

- ▶ when the guard is open up to the distance  $S_{ar}$  (assured release distance), a hazard is excluded.
- ▶ the actuator is positively mounted on the guard, e.g. by using the safety screws included. Tighten the screws with a torque of max. 0.5 Nm.

▶ they cannot be removed or tampered with using simple means. Pay particular attention to EN ISO 14119: 2025, section 8, regarding the possibilities for bypassing an interlocking device.

## Electrical connection

**Warning!** In the event of a fault, loss of the safety function due to incorrect connection.

Lay the connecting cables with protection to prevent the risk of short circuits.

Fusing of the power supply and the safety contacts: Provide external contact fuse (4 A gG) for relay outputs.

**Caution!** Risk of damage to equipment or malfunctions as a result of incorrect connection.

All the electrical connections must either be isolated from the mains supply by a safety transformer according to EN IEC 61558-2-6 with limited output voltage in the event of a fault, or by other equivalent isolation measures.

This device is intended to be used with a Class 2 power source in accordance with UL1310.

As an alternative an LV/C (Limited Voltage/Current) power source with the following properties can be used:

This device shall be used with a suitable isolating source in conjunction with a fuse in accordance with UL248. The fuse shall be either rated max. 4 A and be installed in the max. 24 V DC power supply or it shall be rated 3.3 A and be installed in the max. 30 V DC power supply to the device in order to limit the available current to comply with the UL requirements. Please note possibly lower connection ratings for your device (refer to the technical data).

The devices are tested in accordance with UL508 and CSA/C22.2 no. 14 (protection against electric shock and fire) and are intended for rail mounting in the control cabinet.

They are not tested as safety components in the context of the UL definition (e.g. for potentially explosive atmospheres).

All electrical outputs must have an adequate protective circuit for inductive loads. The outputs must be protected with a free-wheeling diode for this purpose.

The tightening torque for the screws on the connection terminals must be 0.6 ... 0.8 Nm.

If no read heads or other electromagnetic safety switchgear is connected to the plug-in terminals provided in the evaluation units, the jumpers supplied must be inserted in accordance with the connection diagram.

## Safety in case of faults

Terminals A1 and A2 for connection of the power supply and all outputs (safety and auxiliary contacts) are reverse polarity protected.

## Setup

If the evaluation unit does not appear to function when operating voltage is applied (green Power LED does not illuminate), the unit must be returned unopened to the manufacturer.

Check whether the safety contacts are being switched (see LED displays) by opening and closing the safety door.

## LED displays

The LEDs K1 and K2 indicate whether actuator and read head are correctly aligned in relation to each other. The status of the safety contacts cannot be seen from the LEDs.

Function	LED	Color	State
Operating voltage on	Power	green	ON
Operating voltage off			OFF
Contacts 13/14, 23/24 open and 31/32 closed	K1 K2	green green	OFF
Contacts 13/14, 23/24 closed and 31/32 open			ON

## Service and inspection

No servicing is required. **Regular inspection** of the following is necessary to ensure trouble-free long-term operation:

- ▶ Correct switching function
- ▶ Secure mounting of components
- ▶ Loose connections

In the event of damage or wear, the damaged system component must be replaced.

If the safety door is not frequently used, the system must be subjected to a regular function test as part of the inspection schedule.

## Declaration of conformity

The product complies with the requirements according to

- ▶ Machinery Directive 2006/42/EC (until January 19, 2027)
- ▶ Machinery Regulation (EU) 2023/1230 (from January 20, 2027)

The EU declaration of conformity can be found at [www.euchner.com](http://www.euchner.com). Enter the order number of your device in the search box. The document is available under *Downloads*.

## Service

If servicing is required, please contact:

EUCHNER GmbH + Co. KG  
Kohlhammerstraße 16  
70771 Leinfelden-Echterdingen

**Service telephone:**  
+49 711 7597-500

**E-mail:**  
[support@euchner.de](mailto:support@euchner.de)

**Internet:**  
[www.euchner.com](http://www.euchner.com)

**Technical data**

Parameter	Value	Unit
Housing material	Polyamide PA6.6	
Dimensions	114 x 99 x 22.5	mm
Weight	0.22	kg
Ambient temperature	0 ... +55	°C
Storage temperature	-25 ... +70	°C
Degree of protection	Terminals IP20/housing IP40	
Degree of contamination	2	
Mounting	Mounting rail 35 mm acc. to EN IEC 60715 TH35	
Number of read heads	1 ... 30 read heads with reed contacts, 1 ... 10 read heads with Hall sensors	
Connection	Connection terminals	
Operating voltage $U_b$	24 ±10%	V AC/DC
Internal fuse (operating voltage $U_b$ )	750 (automatically resetting fuse PTC)	mA
Safety contacts	2 NO contacts	
Auxiliary contact	1 NC contact	
Switching voltage $U_{max}$	240	V AC
Current consumption at DC 24 V	10 ... 110	mA
Switching current $I_{max}$ at 24 V	3	A
Switching current $I_{min}$ at 24 V	10	mA
Breaking capacity $P_{max}$	720	VA
External contact fuses	4	A gG
Switching current $I_{max}$ at DC 24 V	1.5	A
Utilization category	$I_b$ <sup>1)</sup>	$U_b$ <sup>1)</sup>
	AC-1	3 A
	AC-1	3 A
	AC-15	0.9 A
	AC-15	0.9 A
	DC-13	1.5 A
Switching load acc. to UL Class 2	Input: 24 V AC/DC Output: 30 V AC 24 V DC	
Rated insulation voltage $U_i$	250	V
Shock and vibration resistance	Acc. to EN IEC 60947-5-3	
Mechanical operating cycles, relay	10 <sup>7</sup>	
EMC compliance	Acc. to EN IEC 60947-5-3	
Approval	TÜV, UL	
LED displays	See drawing	
Risk time	20	ms
<b>Characteristics acc. to EN ISO 13849-1</b>		
as a function of the switching current at 24 V DC	≤ 0.1	≤ 1
Number of switching cycles/year	< 166,000	< 70,000
Mission time	20	years
Category		
	1 read head	4
	>1 read head	3
Performance Level (PL)		
	1 read head	e
	>1 read head	d <sup>2)</sup>
PFH		
	1 read head	2.5 x 10 <sup>-8</sup>
	>1 read head	1.0 x 10 <sup>-7 2)</sup>

1)  $I_b$  = max. switching current per contact,  $U_b$  = switching voltage  
 2) This value applies to cables laid with protection.  
 The following applies if cables are laid without protection and more than one door must be opened frequently or if cables are laid without protection and more than 5 doors are connected in series:  
 Performance Level = PL c, PFH = 1.1<sup>6</sup>.  
 More information about this is available in EN ISO 14119:2025, section 9.4.  
 Evaluation of the diagnostic coverage according to EN ISO 14119:2025, section 9.4, must result in at least the value low in order to achieve PL d.

**Combination options for evaluation unit CMS-E-ER**

Design	Read head	Circuit diagram, not actuated <sup>3)</sup>	Actuator	Assured operating distance $S_{ao}$ [mm] <sup>4)</sup>	Assured release distance $S_{ar}$ [mm]
Evaluation unit CMS-E-ER			CMS-MAC	6	31
			CMS-MBD	3	12
			CMS-MCA	6	14
			CMS-MEF	6	17
			CMS-MH-AA	10	20
			CMS-MH-BB	6	13

3) Old conductor coloring in brackets.  
 4) There must be no ferromagnetic material in the vicinity of the read head or the actuator. All data refer to the frontal approach direction and a center offset of  $m = 0$ .  
 5) The minimum operating distances  $S_{a\min}$  between read head and actuator are 1 mm. If the distances are less than this, the evaluation unit can change to the fault state.

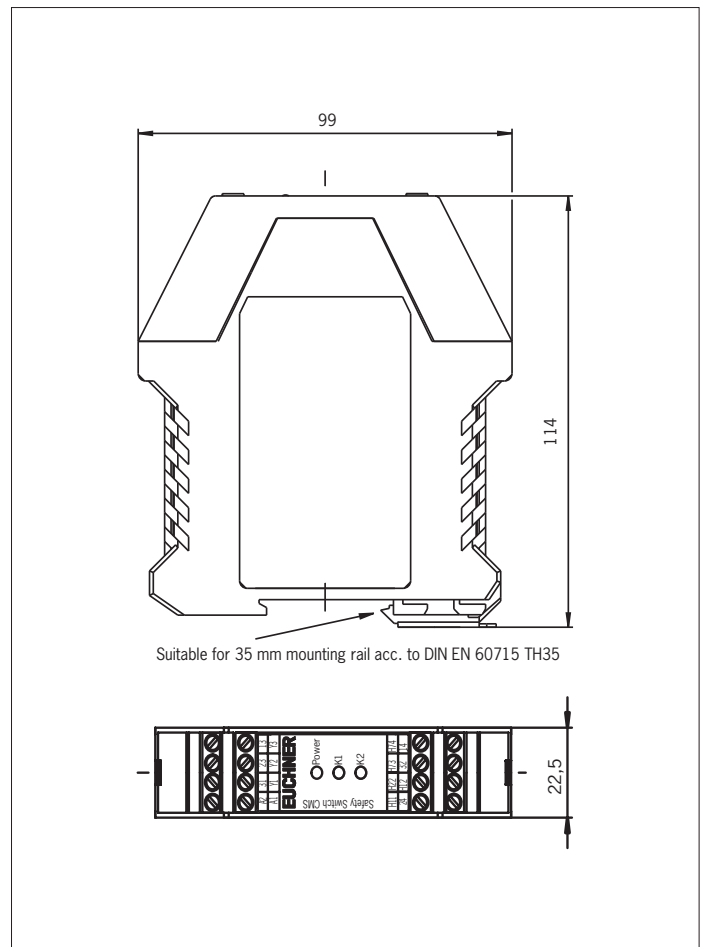
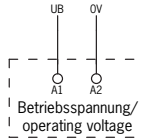
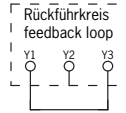

Fig. 1: Dimension drawing for evaluation unit CMS-E-ER

Operating voltage connection



Connection for automatic start without feedback loop



Connection for automatic start with feedback loop

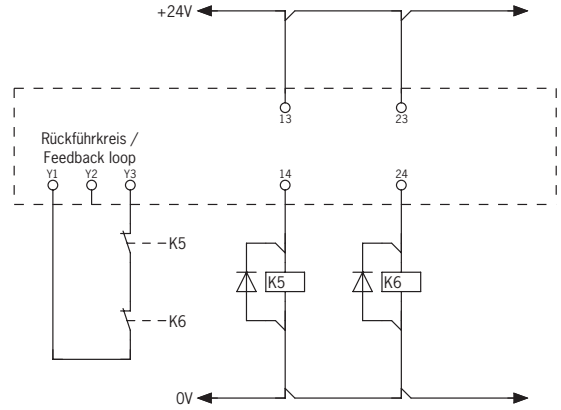

Manual start using start button with falling edge and connected feedback loop

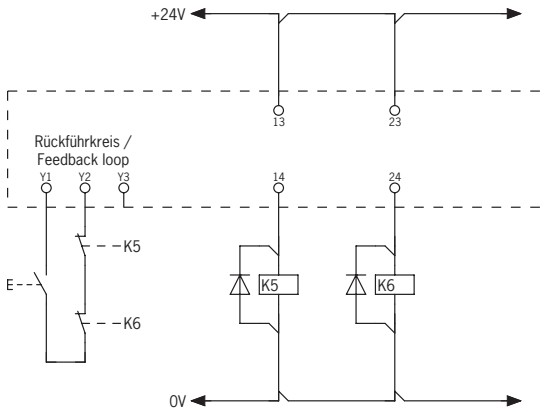

Manual start using start button with rising edge and connected feedback loop

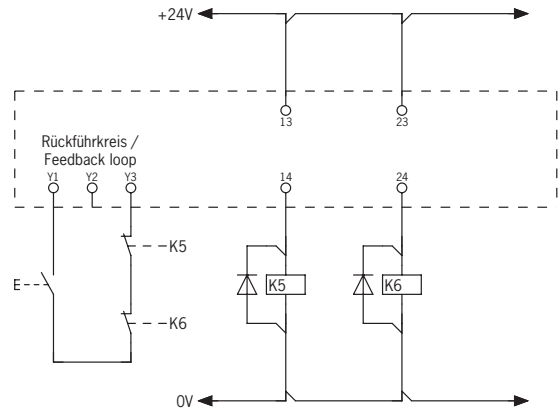

Wiring diagram for one read head CMS-R...

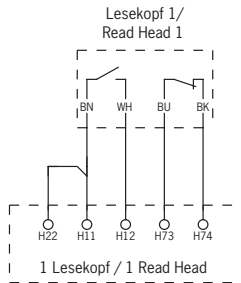

Wiring diagram for one read head CMS-RH...

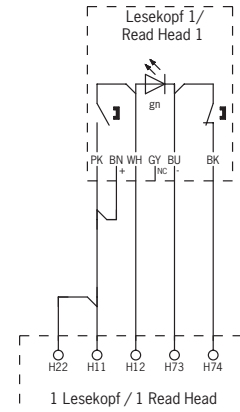

Wiring diagram for 2 read heads CMS-R...

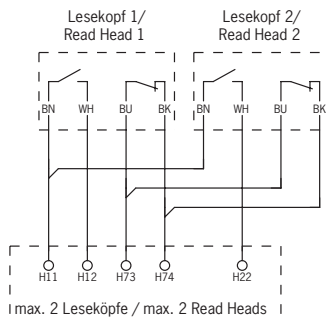

Wiring diagram for 2 read heads CMS-RH...

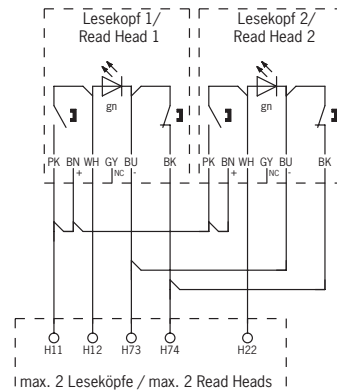

The following applies to all the illustrations:  
 ▶ Evaluation unit electrically isolated  
 ▶ Actuator not in the actuating range

Fig. 2: Wiring diagram for CMS-E-ER, part 1 (continued on next page)

Subject to technical modifications; no responsibility is accepted for the accuracy of this information. © EUCHNER GmbH + Co. KG 2102344-13-11/25 (translation of the original operating instructions)

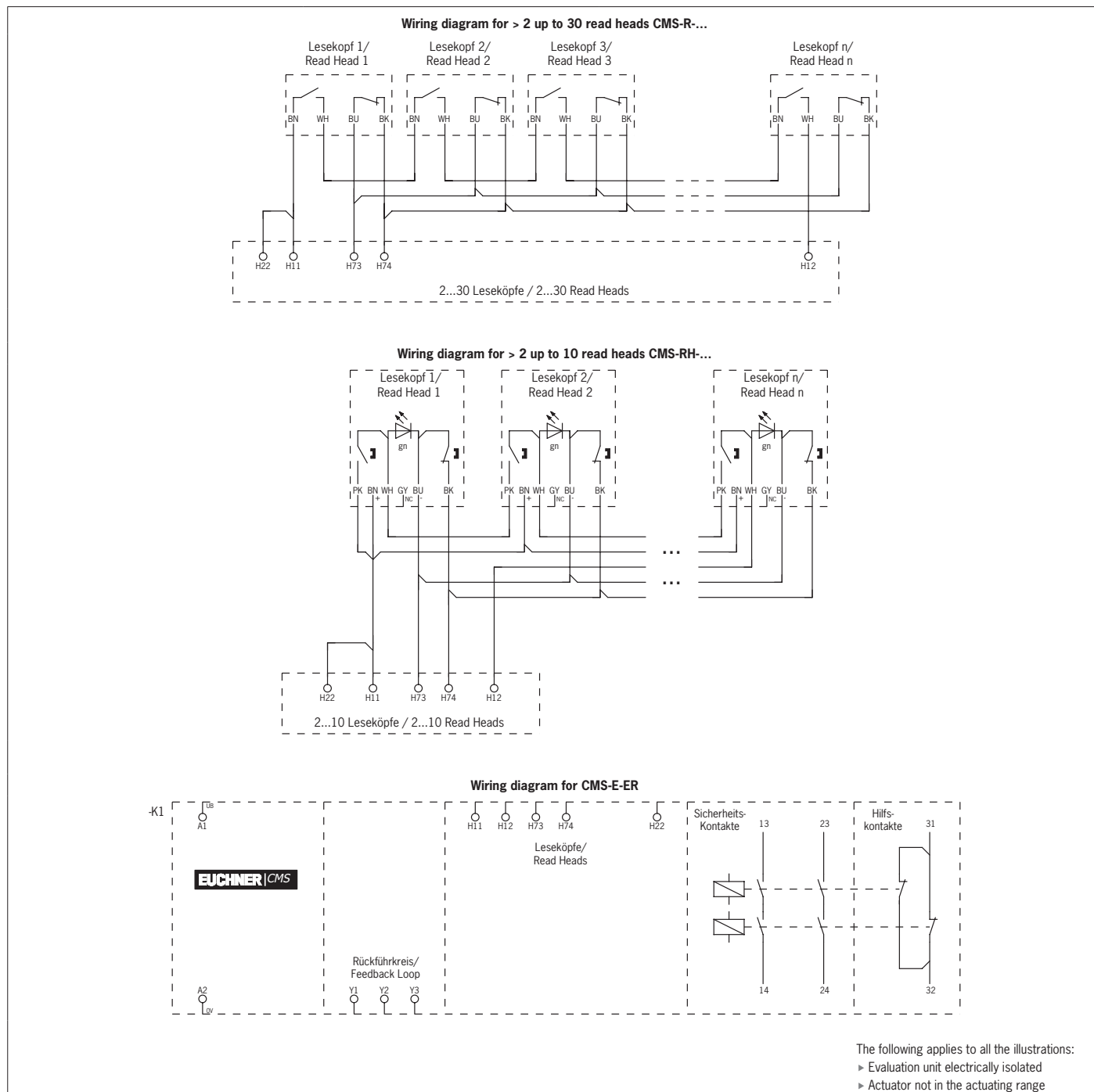

Fig. 3: Wiring diagram for CMS-E-ER, part 2