

EUCHNER

Operating Instructions

Non-Contact Safety Switch
CES-I-BP-.-C07-... (Unicode/Multicode)

EN

Contents

1.	About this document	4
1.1.	Scope.....	4
1.2.	Target group	4
1.3.	Key to symbols.....	4
1.4.	Supplementary documents	4
2.	Correct use	5
3.	Description of the safety function	6
4.	Exclusion of liability and warranty	6
5.	General safety precautions	6
6.	Function	7
6.1.	Diagnostic output OD/C	7
6.1.1.	Door monitoring output OD	7
6.1.2.	Communication output OC	7
6.2.	Limit-range monitoring	7
6.3.	Switching states	8
7.	Mounting	9
8.	Electrical connection	10
8.1.	Notes about $c(U_L)_{US}$	11
8.2.	Safety in case of faults.....	11
8.3.	Fuse protection for power supply	11
8.4.	Requirements for connecting cables.....	11
8.5.	Connector assignment of safety switch CES-I-BP-.-SB	12
8.6.	Connector assignment of safety switch CES-I-BP-.-SI	12
8.7.	Connection.....	13
8.8.	Connection to a BR evaluation unit	14
8.8.1.	Overview of the communication data	14
8.8.2.	Cyclical data (process data).....	14
8.9.	Notes on operation with safe control systems.....	14
9.	Setup	15
9.1.	LED displays	15
9.2.	Teach-in function for actuator (only for unicode evaluation)	15
9.2.1.	Preparing device for the teach-in operation and teaching in actuator	15
9.3.	Functional check.....	16
9.3.1.	Electrical function test.....	16
10.	System status table CES-I-BP-.-	17

11.	Technical data	18
11.1.	Technical data for safety switch CES-I-BP-C07-.....	18
11.1.1.	Radio frequency approvals.....	19
11.1.2.	Typical system times.....	20
11.1.3.	Dimension drawing for safety switch CES-I-BP-C07-... ..	20
11.2.	Technical data for actuator CES-A-BTN-C07-... ..	21
11.2.1.	Dimension drawing.....	21
11.2.2.	Operating distances and installation orientations	22
11.3.	Technical data for actuator CES-A-BDN-06-158210.....	24
11.3.1.	Dimension drawing.....	24
11.3.2.	Switching distances*	25
12.	Ordering information and accessories	26
13.	Inspection and service	26
14.	Service	26
15.	Declaration of conformity	27

1. About this document





1.1. Scope

These operating instructions apply to all CES-I-BP-.-C07-... from version 1.0.0. These operating instructions, the document "Safety information and maintenance" and any enclosed data sheet form the complete user information for your device.

1.2. Target group



Design engineers and installation planners for safety devices on machines, as well as setup and servicing staff possessing special expertise in handling safety components.

1.3. Key to symbols

Symbol/depiction	Meaning
	Printed document
	Document is available for download at www.euchner.com
	Document on CD
 DANGER WARNING CAUTION	Safety precautions Danger of death or severe injuries Warning about possible injuries Caution slight injuries possible
 NOTICE Important!	Notice about possible device damage Important information
Tip	Useful information

1.4. Supplementary documents

The overall documentation for this device consists of the following documents:

Document title (document number)	Contents	
Safety Information and Maintenance Safety Switch CES-AP/ CES-AR/CES-BP/CES-BR (2514431)	Basic information for safe setup and service	
Operating Instructions (2528734)	(this document)	
Possibly enclosed data sheet	Item-specific information about deviations or additions	

	Important! Always read all documents to gain a complete overview of safe installation, setup and use of the device. The documents can be downloaded from www.euchner.com . For this purpose enter the doc. no. or the order number for the device in the search box.
---	---

2. Correct use

Safety switches series CES-I-BP are interlocking devices without guard locking (type 4). The device meets the requirements according to EN IEC 60947-5-3. Devices with unicode evaluation possess a high coding level, devices with multicode evaluation possess a low coding level.

In combination with a movable guard and the machine control, this safety component prevents dangerous machine functions from occurring while the guard is open. A stop command is triggered if the guard is opened during the dangerous machine function.

This means:

- Starting commands that cause a dangerous machine function must become active only when the guard is closed.
- Opening the guard triggers a stop command.
- Closing a guard must not cause automatic starting of a dangerous machine function. A separate start command must be issued. For exceptions, refer to EN ISO 12100 or relevant C-standards.

Before the device is used, a risk assessment must be performed on the machine, e.g. in accordance with the following standards:

- EN ISO 13849-1
- EN ISO 12100
- IEC 62061

Correct use includes observing the relevant requirements for installation and operation, particularly based on the following standards:

- EN ISO 13849-1
- EN ISO 14119
- EN 60204-1

The safety switch is only allowed to be operated in conjunction with the intended EUCHNER CES actuators and the related connection components from EUCHNER. On the use of different actuators or other connection components, EUCHNER provides no warranty for safe function.



Important!

- The user is responsible for the proper integration of the device into a safe overall system. For this purpose, the overall system must be validated, e.g. in accordance with EN ISO 13849-2.
- It is only allowed to use components that are permissible in accordance with the table below.

Table 1: Possible combinations for CES components

Safety switch	Actuator	
	CES-A-BTN-C07-...	CES-A-BDN-C06-...
CES-I-BP-.-C07-...	●	●
Key to symbols	●	Combination possible

3. Description of the safety function

Devices from this series feature the following safety functions:

Monitoring of the guard position (interlocking device according to EN ISO 14119)

- Safety function:
 - The safety outputs are switched off when the guard is open (see chapter 6.3. *Switching states on page 8*).
- Safety characteristics: category, Performance Level, PFH_D (see chapter 11. *Technical data on page 18*).

4. Exclusion of liability and warranty

In case of failure to comply with the conditions for correct use stated above, or if the safety regulations are not followed, or if any servicing is not performed as required, liability will be excluded and the warranty void.

5. General safety precautions

Safety switches fulfill personnel protection functions. Incorrect installation or tampering can lead to fatal injuries to personnel.

Check the safe function of the guard particularly

- after any setup work
- after the replacement of a system component
- after an extended period without use
- after every fault

Independent of these checks, the safe function of the guard should be checked at suitable intervals as part of the maintenance schedule.



WARNING

Danger to life due to improper installation or due to bypassing (tampering). Safety components fulfill a personnel protection function.

- Safety components must not be bypassed, turned away, removed or otherwise rendered ineffective. On this topic pay attention in particular to the measures for reducing the possibility of bypassing according to EN ISO 14119:2013, section 7.
- The switching operation must be triggered only by actuators designated for this purpose.
- Prevent bypassing by means of replacement actuators (only for multicode evaluation). For this purpose, restrict access to actuators and to keys for releases, for example.
- Mounting, electrical connection and setup only by authorized personnel possessing the following knowledge:
 - specialist knowledge in handling safety components
 - knowledge about the applicable EMC regulations
 - knowledge about the applicable regulations on operational safety and accident prevention.



Important!

Prior to use, read the operating instructions and keep these in a safe place. Ensure the operating instructions are always available during mounting, setup and servicing. For this reason you should archive a printed copy of the operating instructions. You can download the operating instructions from www.euchner.com.

6. Function

The safety switch monitors the position of movable guards. The safety outputs are switched on/off when the actuator is moved into/out of the operating distance.

The system consists of the following components: coded actuator (transponder) and switch.

Whether the device learns the complete actuator code (unicode) or not (multicode) depends on the respective version.

- › **Devices with unicode evaluation:** The actuator must be assigned to the safety switch by a teach-in operation so that it is detected by the system. This unambiguous assignment ensures a particularly high level of protection against tampering. The system thus possesses a high coding level.
- › **Devices with multicode evaluation:** Unlike systems with unique code detection, on multicode devices a specific code is not requested but instead it is only checked whether the actuator is of a type that can be detected by the system (multicode detection). There is no exact comparison of the actuator code with the taught-in code in the safety switch (unique code detection). The system possesses a low coding level.

When the guard is closed, the actuator is moved towards the safety switch. When the switch-on distance is reached, power is supplied to the actuator by the switch and data are transferred.

If a permissible code is detected, the safety outputs are switched on.

The safety outputs are switched off when the guard is opened.

In the event of a fault in the safety switch, the safety outputs are switched off and the DIA LED illuminates red. The occurrence of faults is detected at the latest on the next demand to close the safety outputs (e.g. on starting).

6.1. Diagnostic output OD/C

The device has a diagnostic output that can be used either as a door monitoring output or as a communication output to a BR evaluation unit (e.g. ESM-CB). During starting, the device automatically detects whether it is connected to an input on a BR evaluation unit. In this case the diagnostic output OD/C operates as a communication output OC.

6.1.1. Door monitoring output OD

The door monitoring output is switched on as soon as a valid actuator is detected in the operating distance.

6.1.2. Communication output OC

The communication output is used to exchange data with an evaluation unit for BR series connections. The switch delivers process data determined cyclically. Acyclical data can also be sent by means of specifically polling by the evaluation unit. You will find an overview of the communication data in chapter 8.8. *Connection to a BR evaluation unit.*

6.2. Limit-range monitoring

If the safety door with the actuator should settle over time, the actuator can drift out of the read head operating distance. The device recognizes this situation and indicates that the actuator is in the limit range by flashing the STATE LED. This allows the safety door to be readjusted in time. Also see chapter 10. *System status table CES-I-BP-... on page 17.*

6.3. Switching states

The detailed switching states for your switch can be found in the system status table (see chapter 10). All safety outputs, monitoring outputs and display LEDs are described there.

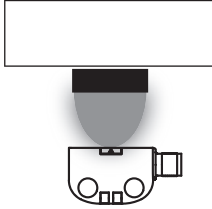
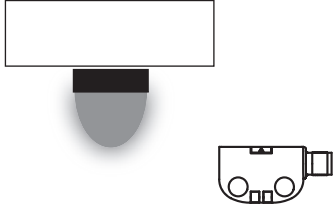
	Guard closed (actuator in the operating distance and permissible code detected)	Guard open (actuator not in the operating distance)
		
Safety outputs FO1A and FO1B	on	off
Door monitoring output OD	on	off

7. Mounting



CAUTION

Safety switches must not be bypassed (bridging of contacts), turned away, removed or otherwise rendered ineffective.

- › Observe EN ISO 14119:2013, section 7, for information about reducing the possibilities for bypassing an interlocking device.



NOTICE

Risk of damage to equipment and malfunctions as a result of incorrect installation.

- › Safety switches and actuators must not be used as an end stop.
- › Observe EN ISO 14119:2013, sections 5.2 and 5.3, for information about mounting the safety switch and the actuator.
- › From the assured switch-off distance S_{ar} , the safety outputs are safely shut down.
- › When mounting several safety switches, observe the stipulated minimum distance to avoid mutual interference.

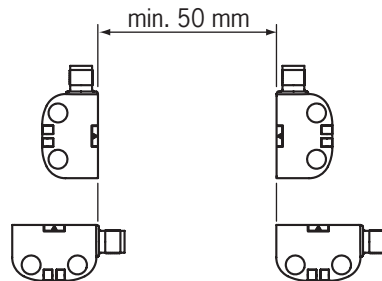

- › The switching distance changes during the mounting of the actuator as a function of the material used for the guard.
- › Observe direction of arrow on the device (see figure below).

Permissible installation orientations

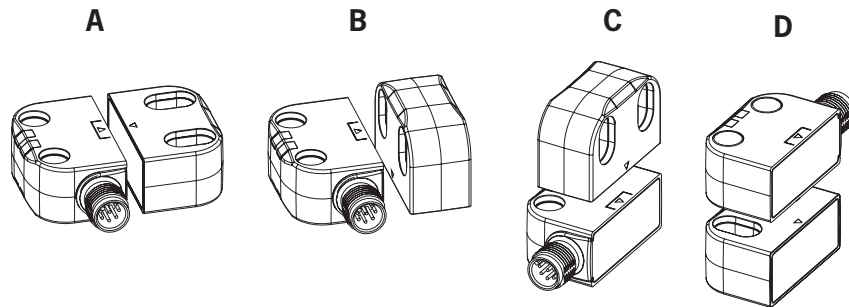

Note the following points:

- › Actuator and safety switch must be easily accessible for inspection and replacement.
- › Actuator and safety switch must be fitted so that
 - a minimum distance is maintained with a side approach direction to avoid entering the area of possible side lobes. See chapter 11. *Technical data*, section *Typical operating distance* for the related actuator.
 - when the guard is open up to the distance S_{ar} (assured switch-off distance), a hazard is excluded.
 - the actuator is positively mounted on the guard, e.g. by using the safety screws included.
 - the safety screws cannot be removed or tampered with using simple means.
- › Pay attention to the maximum tightening torque for the read head or safety switch and actuator fastenings of 0.8 Nm.
- › Seal the mounting holes after mounting using the caps provided to prevent the accumulation of dirt.
- › In order to avoid damage, the connecting cable must be laid with protection in areas in which high-pressure cleaners are used.

8. Electrical connection



WARNING

- If there is a mistake, loss of the safety function due to incorrect connection.
- › To ensure safety, both safety outputs must always be evaluated.
 - › Monitoring outputs must not be used as safety outputs.
 - › Lay the connecting cables with protection to prevent the risk of short circuits.



CAUTION

- Risk of damage to equipment or malfunctions as a result of incorrect connection.
- › Do not use a control system with pulsing or switch off the pulsing function in your control system. The device generates its own test pulses on the safety outputs. A downstream control system must tolerate these test pulses, which may have a length of up to 300 μ s. The test pulses are output only with the safety outputs switched off during device start. Depending on the inertia of the downstream device (control system, relay, etc.), this can lead to short switching processes.
 - › The inputs on a connected evaluation unit must be positive-switching, as the two outputs on the safety switch deliver a level of +24 V in the switched-on state.
 - › All the electrical connections must either be isolated from the mains supply by a safety transformer according to IEC 61558-2-6 with limited output voltage in the event of a fault, or by other equivalent isolation measures (PELV).
 - › All electrical outputs must have an adequate protective circuit for inductive loads. The outputs must be protected with a free-wheeling diode for this purpose. RC interference suppression units must not be used.
 - › Power devices which are a powerful source of interference must be installed in a separate location away from the input and output circuits for signal processing. The cable routing for safety circuits should be as far away as possible from the cables of the power circuits.
 - › To avoid EMC interference, the physical environmental and operating conditions at the installation site of the device must comply with the requirements according to the standard EN 60204-1:2006, section 4.4.2 (EMC).
 - › Pay attention to any interference fields from devices such as frequency converters or induction heating systems. Observe the EMC instructions in the manuals from the respective manufacturer.





Important!

If the device does not appear to function when operating voltage is applied (e.g. green STATE LED does not flash), the safety switch must be returned unopened to the manufacturer.

8.1. Notes about



Important!

- › For use and operation as per the  requirements ¹⁾, a power supply with the feature "for use in Class 2 circuits" must be used.
Alternative solutions must comply with the following requirements:
 - Electrically isolated power supply unit with a max. open-circuit voltage of 30 V DC and a limited current of max. 8 A.
- › For use and applications as per the requirements of  ¹⁾, a connecting cable listed under the UL category code CYJV2 or CYJV must be used.

1) Note on the scope of the UL approval: the devices have been tested as per the requirements of UL508 and CSA/ C22.2 no. 14 (protection against electric shock and fire). Only for applications as per NFPA 79 (Industrial Machinery).

8.2. Safety in case of faults

- › The operating voltage U_B is reverse polarity protected.
- › The safety outputs are short circuit-proof.
- › A short circuit between the safety outputs is detected by the switch.
- › A short circuit in the cable can be excluded by laying the cable with protection.

8.3. Fuse protection for power supply

The power supply must be provided with fuse protection depending on the number of switches and current required for the outputs. The following rules apply:

Max. current consumption of an individual switch I_{max}

$$I_{max} = I_{UB} + I_{OD} + I_{F01A+F01B}$$

$$I_{UB} = \text{Switch operating current (40 mA)}$$

$$I_{OD} = \text{Load current of monitoring outputs (max. 50 mA)}$$

$$I_{F01A+F01B} = \text{Load current of safety outputs F01A + F01B (2 x max. 150 mA)}$$

8.4. Requirements for connecting cables



CAUTION

- Risk of damage to equipment or malfunctions as a result of incorrect connecting cables.
- › Use connection components and connecting cables from EUCHNER.
 - › On the use of other connection components, the requirements in the following table apply.
EUCHNER provides no warranty for safe function in case of failure to comply with these requirements.
 - › Observe the maximum cable length of 200 m.

Observe the following requirements with respect to the connecting cables:

Parameter	Value	Unit
Conductor cross-section, min.	0.25... 0.34	mm ²
R max.	80	Ω/km
C max.	120	nF/km
L max.	0.65	mH/km
Recommended cable type	LIYY 8 x 0.34 mm ²	

8.5. Connector assignment of safety switch CES-I-BP-...-SB

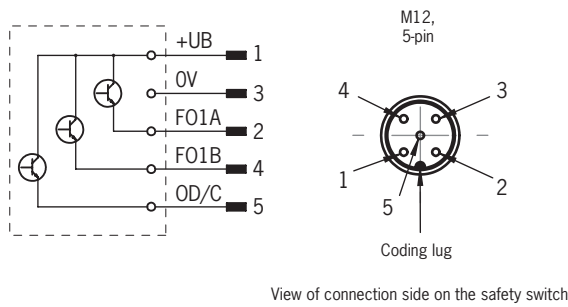

Figure 1: Connector assignment of safety switch CES-I-BP-...-SB

Pin	Designation	Description
1	UB	Power supply, DC 24 V
2	FO1A	Safety output, channel 1
3	OV	Ground, DC 0 V
4	FO1B	Safety output, channel 2
5	OD/C	Door monitoring output/communication output

8.6. Connector assignment of safety switch CES-I-BP-...-SI

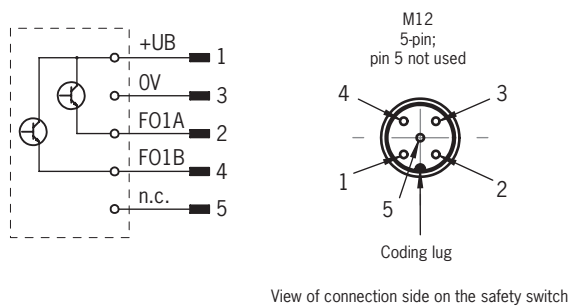

Figure 2: Connector assignment of safety switch CES-I-BP-...-SI

Pin	Designation	Description
1	UB	Power supply, DC 24 V
2	FO1A	Safety output, channel 1
3	OV	Ground, DC 0 V
4	FO1B	Safety output, channel 2
5	-	n.c.

8.7. Connection



WARNING

If there is a mistake, loss of the safety function due to incorrect connection.
 ▶ To ensure safety, both safety outputs (FO1A and FO1B) must always be evaluated.



Important!

The example shows only an excerpt that is relevant for connection of the CES system. The example illustrated here does not show complete system planning. The user is responsible for safe integration into the overall system. Detailed application examples can be found at www.euchner.com. Simply enter the order number of your switch in the search box. All available connection examples for the device can be found in "Downloads."

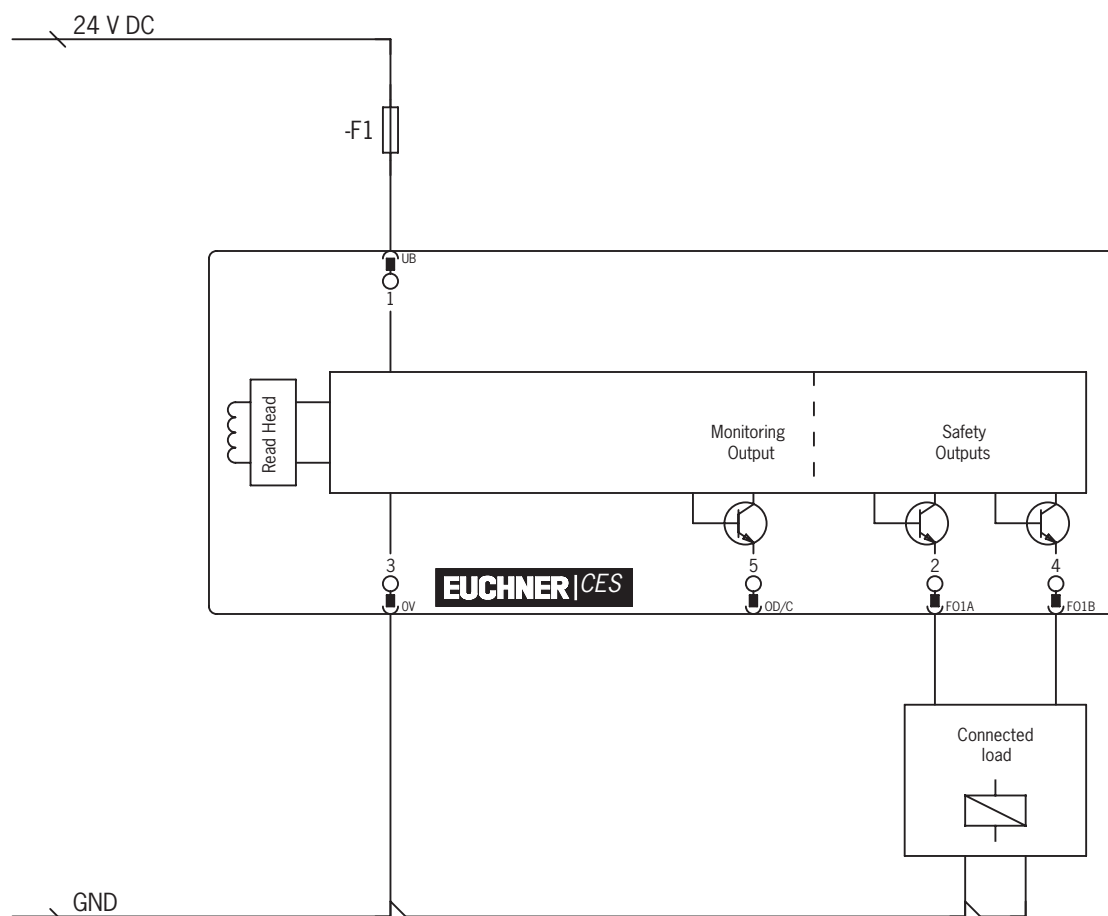

Figure 3: Connection example CES-I-BP-...

8.8. Connection to a BR evaluation unit



Important!

- The example shows only an excerpt that is relevant for connection of the CES system. The example illustrated here does not show complete system planning. The user is responsible for safe integration into the overall system. Detailed application examples can be found at www.euchner.com. Simply enter the order number of your switch in the search box. You will find all available connection examples for the device in Downloads.

To poll the communication data from the connected switch, diagnostic output OD/C is routed to the BR evaluation unit.

On the use of the BR evaluation unit ESM-CB, the following applies:

The safety outputs for the switch are routed to the corresponding inputs on the BR evaluation unit ESM-CB. If a safety door is opened or if a fault occurs on the switch, the BR evaluation unit ESM-CB shuts down the machine.

8.8.1. Overview of the communication data

The switch transmits both process data that are continuously transmitted to the evaluation unit (cyclical data) and data that can be polled specifically as needed (acyclical data). For further information on connection and on the communication data, please refer to the operating instructions for your BR evaluation unit.

8.8.2. Cyclical data (process data)

Table 2: Cyclical data (process data)

Data		Meaning
Guard position	OD	This signal indicates whether the guard is open or closed.
Weak-range indication	OW	This signal provides timely information about whether an actuator is in the limit range of the transponder field. This situation usually occurs when safety doors settle over time, causing the actuator to drift out of the operating distance. The weak-range indication signals this state early enough for you to readjust the safety door.
Safety outputs switched	OM	This signal indicates whether the safety outputs are switched on. The guard must be closed and all other conditions must be met for this purpose. The safety outputs of all preceding devices in the series connection are switched on, for example.
Message pending	OI	This signal indicates a pending message. You can retrieve it via the acyclical data.
State of the device preceding the switch	OR	Indicates whether the preceding switch in the series connection has switched on the safety outputs.

8.9. Notes on operation with safe control systems

Please observe the following requirements for connection to safe control systems:

- Use a common power supply for the control system and the connected safety switches.
- The device tolerates voltage interruptions at UB up to 5 ms in duration, provided that the time between two voltage interruptions is at least 500 ms. Tap the supply voltage directly from the power supply unit. If the supply voltage is connected to a terminal of a safe control system, this output must provide sufficient electrical current.
- The safety outputs (FO1A and FO1B) can be connected to the safe inputs of a control system. Prerequisite: the input must be suitable for pulsed safety signals (OSSD signals, e.g. from light grids). The control system must tolerate test pulses on the input signals. This normally can be set up by parameter assignment in the control system. Observe the notes of the control system manufacturer. For the test-pulse duration of your safety switch, please refer to chapter 11. *Technical data on page 18.*

A detailed example of connection and setting the parameters of the control system is available for many devices at www.euchner.com in the area Download » Applications » CES. The features of the respective device are dealt with there in greater detail.

9. Setup

9.1. LED displays

You will find a detailed description of the signal functions in chapter 10. *System status table CES-I-BP-... on page 17.*

LED	Color
STATE	green
DIA	red

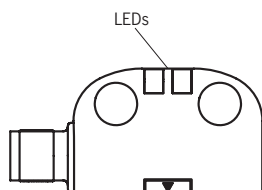

9.2. Teach-in function for actuator (only for unicode evaluation)

The actuator must be allocated to the safety switch using a teach-in function before the system forms a functional unit.

During a teach-in operation, the safety outputs and the monitoring output OD/C are switched off, i.e. the system is in the safe state.



Tip!

It is recommended to perform the teach-in operation prior to mounting. Mark switches and actuators that belong together in order to avoid confusion.



Important!

- › The teach-in operation may be performed only if the device functions flawlessly. The red DIA LED must not be illuminated.
- › The safety switch disables the code of the preceding device if teach-in is carried out for a new actuator. Teach-in is not possible again immediately for this device if a new teach-in operation is carried out. The disabled code is released again in the safety switch only after a third code has been taught in.
- › The safety switch can be operated only with the last actuator taught in.
- › The number of teach-in operations is unlimited.
- › If the switch detects the actuator that was most recently taught in when in the teach-in standby state, this state is ended immediately and the switch changes to normal operation.
- › If the actuator to be taught in is within the operating distance for less than 30 s, it will not be activated and the most recently taught in actuator will remain saved.

9.2.1. Preparing device for the teach-in operation and teaching in actuator

1. Apply operating voltage to the safety switch.
 - ➔ The green LED flashes quickly (approx. 5 Hz)
A self-test is performed during this time (approx. 5 s). After this, the LED flashes cyclically three times and signals that it is in standby state for teach-in.
Standby state for teach-in remains active for approx. 3 minutes. On switches that have not been taught in, teach-in standby is unlimited.
2. Move new actuator to the read head (observe distance $< S_{a0}$).
 - ➔ Teach-in operation starts, green LED flashes (approx. 1 Hz). During the teach-in operation, the safety switch checks whether the actuator is a disabled actuator. After successful teach-in, the STATE and DIA LEDs flash alternately. The new code has now been stored, and the old code is disabled. The teach-in operation takes approx. 30 s.
3. Disconnect safety switch from the operating voltage for 3 seconds.
 - ➔ The switch is in normal operation after the self-test.

9.3. Functional check



WARNING

Danger of fatal injury as a result of faults in installation and functional check.

- › Before carrying out the functional check, make sure that there are no persons in the danger zone.
- › Observe the valid accident prevention regulations.

9.3.1. Electrical function test

After installation and any fault, the safety function must be fully checked. Proceed as follows:

1. Switch on operating voltage.
 - ➔ The machine must not start automatically.
 - ➔ The safety switch carries out a self-test. The green STATE LED flashes for 5 s at 5 Hz. The green STATE LED then flashes at regular intervals.
2. Close all guards.
 - ➔ The machine must not start automatically.
 - ➔ The green STATE LED illuminates continuously.
3. Enable operation in the control system.
4. Open the guard.
 - ➔ The machine must switch off and it must not be possible to start it as long as the guard is open.
 - ➔ The green STATE LED flashes at regular intervals.

Repeat steps 2 - 4 for each guard.

10. System status table CES-I-BP-...

Operating mode	Actuator/door position	Safety outputs FO1A and FO1B	Monitoring output OD/C	LED indicator Output		State
				STATE (green)	D/A (red)	
Self-test	X	off	off	5 Hz (1.3 s)	○	Self-test after power-up
Normal operation	closed	on	on		○	Normal operation, door closed
	open	off	off	1 x	○	Normal operation, door open
	closed	on	on	flashes quickly 2 Hz	○	Normal operation, door closed, actuator in the limit range → Re-adjust door
Teach-in operation (unicode only)	open	off	off	3 x	○	Door open, device is ready for teach-in for another actuator (only short time after power-up). Switches that have not been taught in remain in teach-in standby until the teach-in operation starts.
	closed	off	on	1 Hz	○	Teach-in operation
	X	off	X	← →		Positive acknowledgment after completion of teach-in operation
Fault display	X	off	X	1 x		Fault in the teach-in operation (only unicode), actuator removed from the operating distance prior to the end of the teach-in operation or faulty actuator detected.
	X	off	off	3 x		Defective or incompatible actuator (e.g. fault in code or code not readable)
	X	off	off	4 x		Output fault (e.g. short circuits, loss of switching ability)
	X	off	X	5 x		Environment error (e.g. temperature or operating voltage in the limit range)
	X	off	off	X	X or	Internal error (e.g. overtemperature, overvoltage/low voltage, output error during power-up or component fault)

Key to symbols	○	LED not illuminated
		LED illuminated
	5 Hz (1.3 s)	LED flashes for 1.3 seconds at 5 Hz
	3 x	LED flashes three times, and this is then repeated
	← →	LEDs flash alternately
	X	Any state

After the cause has been remedied, faults can generally be reset by opening and closing the guard. If the fault is still displayed afterward, briefly interrupt the power supply. Please contact the manufacturer if the fault could not be reset after restarting.



Important!

If you do not find the displayed device status in the system status table, this indicates an internal device fault. In this case, you should contact the manufacturer.

11. Technical data



NOTICE

If a data sheet is included with the product, the information on the data sheet applies.

11.1. Technical data for safety switch CES-I-BP-C07-...

Parameter	Value			Unit
	min.	typ.	max.	
Housing material	PBT-PC-GF30 plastic			
Dimensions	40 x 26.5 x 18			mm
Weight (device without connecting cable)	0.08			kg
Ambient temperature at $U_B = DC\ 24\ V$	- 25	-	+ 55	°C
Storage temperature	- 40	-	+ 70	
Degree of protection	IP65/IP67/IP69/IP69K			
Safety class	III			
Degree of contamination	3			
Installation orientation	Any			
Mounting method	Non-flush			
Connection	Plug connector M12, 5-pin			
Operating voltage U_B (regulated, residual ripple < 5%)	24 ± 15% (PELV)			V DC
Current consumption	40			mA
External fuse (operating voltage)	0.25	-	8	A
Safety outputs F01A/F01B	Semiconductor outputs, p-switching, short circuit-proof			
- Output voltage $U(F01A)/U(F01B)$ ¹⁾				
HIGH U(F01A)	$U_B-1.5$	-	U_B	V DC
HIGH U(F01B)		-	1	
LOW U(F01A)/U(F01B)		0	1	
Switching current per safety output	1	-	150	mA
Utilization category acc. to EN IEC 60947-5-2	DC-13 24 V 150 mA Caution: Outputs must be protected by a free-wheeling diode in the case of inductive loads.			
Off-state current I_r	≤ 0.25			mA
Monitoring output OD/C ¹⁾	p-switching, short circuit-proof			
- Output voltage				
HIGH	$U_B-1.5$	-	U_B	V DC
LOW	0	-	1	
- Switching current	1	-	50	mA
Rated insulation voltage U_i	-	-	300	V
Rated impulse withstand voltage U_{imp}	-	-	1.5	kV
Conditional short-circuit current	100			A
Resilience to vibration	Acc. to EN IEC 60947-5-2			
Switching frequency	-	-	1	Hz
Repeat accuracy R	≤ 10			%
EMC protection requirements	Acc. to EN IEC 60947-5-3			
Ready delay	-	1.3	-	s
Risk time	-	-	125	ms
Switch-on time	-	-	100	ms
Discrepancy time	-	-	10	ms
Test-pulse duration	0.3			ms
Test-pulse interval	Approx. 100			ms
Reliability values acc. to EN ISO 13849-1:2015				
Category	4			
Performance Level	PL e			
PFH_D	$6 \times 10^{-10} / h$			
Mission time	20			years

1) Values at a switching current of 50 mA without taking into account the cable length.

11.1.1. Radio frequency approvals

FCC ID: 2AJ58-12

IC: 22052-12

FCC/IC-Requirements

This device complies with part 15 of the FCC Rules and with Industry Canada's licence-exempt RSSs. Operation is subject to the following two conditions:

- 1) This device may not cause harmful interference, and
- 2) this device must accept any interference received, including interference that may cause undesired operation.

Changes or modifications not expressly approved by the party responsible for compliance could void the user's authority to operate the equipment.

NOTE: This equipment has been tested and found to comply with the limits for a Class A digital device, pursuant to part 15 of the FCC Rules. These limits are designed to provide reasonable protection against harmful interference when the equipment is operated in a commercial environment. This equipment generates, uses, and can radiate radio frequency energy and, if not installed and used in accordance with the instruction manual, may cause harmful interference to radio communications. Operation of this equipment in a residential area is likely to cause harmful interference in which case the user will be required to correct the interference at his own expense.

Le présent appareil est conforme aux CNR d'Industrie Canada applicables aux appareils radio exempts de licence. L'exploitation est autorisée aux deux conditions suivantes :

- (1) l'appareil ne doit pas produire de brouillage, et
- (2) l'utilisateur de l'appareil doit accepter tout brouillage radioélectrique subi, même si le brouillage est susceptible d'en compromettre le fonctionnement.

11.1.2. Typical system times

Please refer to the technical data for the exact values.

Ready delay: After switch-on, the device carries out a self-test. The system is ready for operation only after this time.

Switch-on time of safety outputs: The max. reaction time t_{on} is the time from the moment when the actuator is in the operating distance to the moment when the safety outputs switch on.

Risk time according to EN 60947-5-3: If an actuator moves outside the operating distance, the safety outputs (FO1A and FO1B) are switched off after the risk time at the latest.

Discrepancy time: The safety outputs (FO1A and FO1B) switch with a slight time offset. They have the same signal state no later than after the discrepancy time.

Test pulses at the safety outputs: The device generates its own test pulses on the safety outputs (FO1A and FO1B). A downstream control system must tolerate these test pulses.

This can usually be set up in the control systems by parameter assignment. If parameter assignment is not possible for your control system or if shorter test pulses are required, please contact our support organization.

11.1.3. Dimension drawing for safety switch CES-I-BP-C07-...

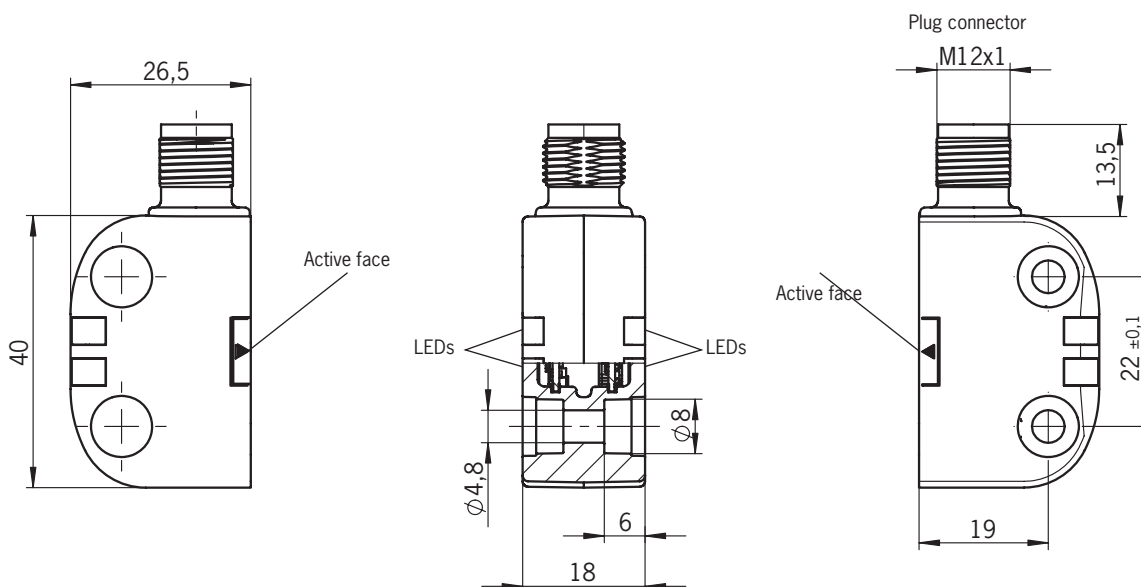

NOTICE

› Covers are included.

11.2. Technical data for actuator CES-A-BTN-C07-...

Parameter	Value			Unit
	min.	typ.	max.	
Housing material	PBT-PC-GF30 plastic			
Dimensions	42 x 25 x 18			mm
Weight	0.03			kg
Ambient temperature	- 40	-	+ 70	°C
Degree of protection	IP65/IP67/IP69/IP69K			
Installation orientation	Active face opposite read head			
Power supply	Inductive via read head			

11.2.1. Dimension drawing

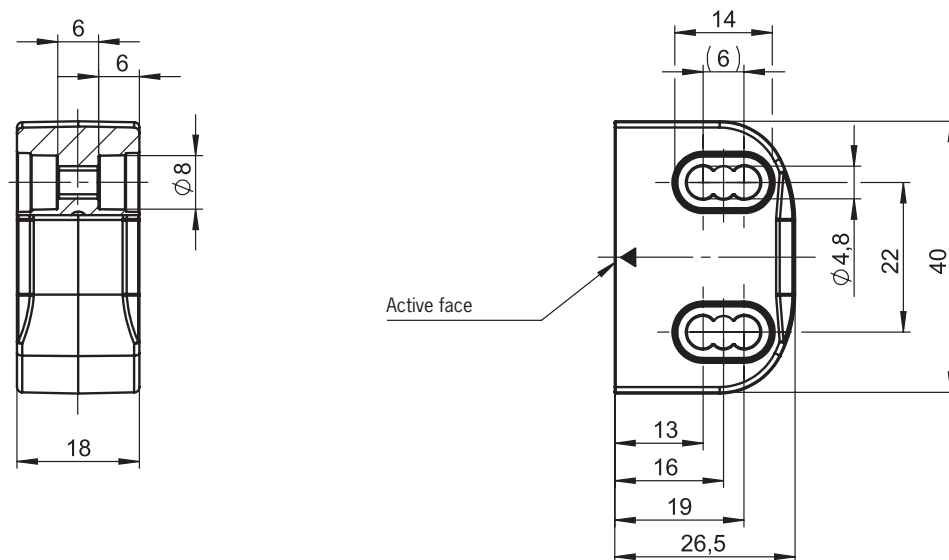

NOTICE

› Two safety screws M4x20 included.

11.2.2. Operating distances and installation orientations

(only in conjunction with actuator CES-A-BTN-C07)

Typical operating distance in installation orientation A

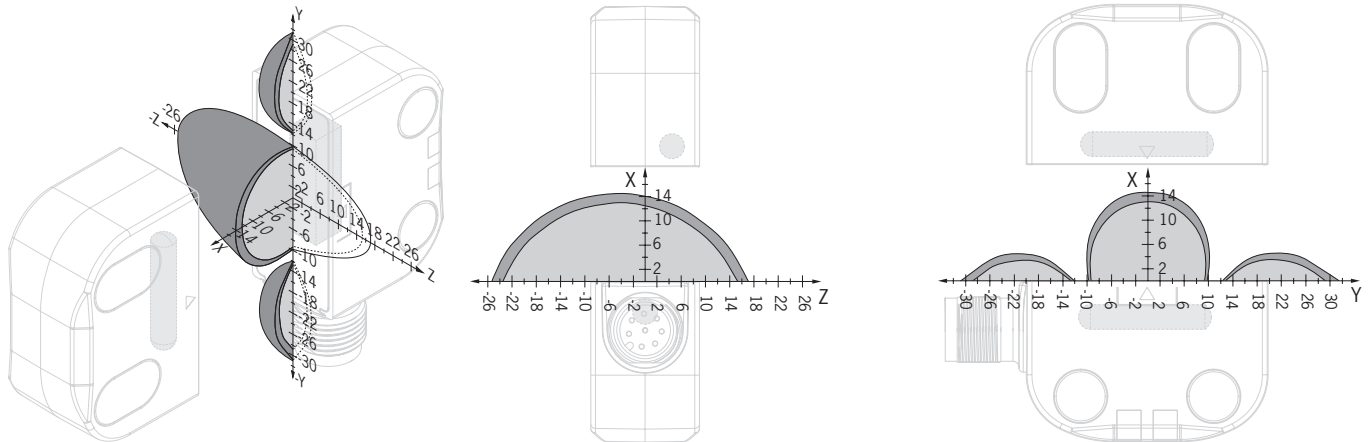

Switching distances for approach from x direction without center offset (z, y = 0)*

Parameter	Value			Unit
	min.	typ.	max.	
Switch-on distance	-	13	-	mm
Assured switch-on distance s_{a0}	10	-	-	
Switching hysteresis ¹⁾	1	2	-	
Assured switch-off distance s_{ar}	-	-	20	

* The data apply to mounting the actuator on a non-metallic substrate. Depending on the substrate material, the operating distance may change.

Typical operating distance in installation orientation B

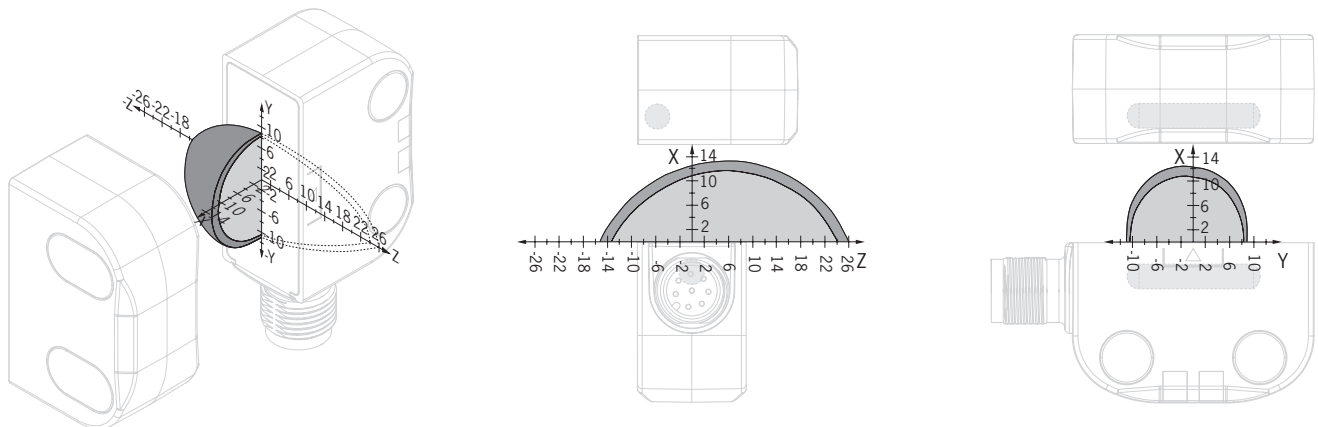

Switching distances for approach from x direction without center offset (z, y = 0)*

Parameter	Value			Unit
	min.	typ.	max.	
Switch-on distance	-	13	-	mm
Assured switch-on distance s_{a0}	9	-	-	
Switching hysteresis ¹⁾	1	2	-	
Assured switch-off distance s_{ar}	-	-	20	

* The data apply to mounting the actuator on a non-metallic substrate. Depending on the substrate material, the operating distance may change.

Typical operating distance in installation orientation C

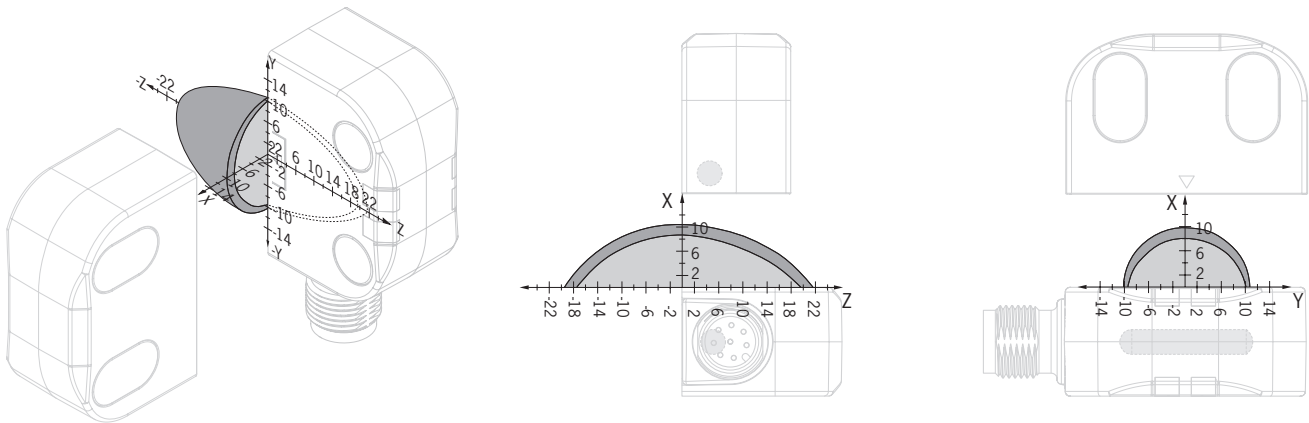

Switching distances for approach from x direction without center offset ($z, y = 0$)*

Parameter	Value			Unit
	min.	typ.	max.	
Switch-on distance	-	7	-	mm
Assured switch-on distance s_{a0}	3	-	-	
Switching hysteresis ¹⁾	1	2	-	
Assured switch-off distance s_{ar}	-	-	17	

* The data apply to mounting the actuator on a non-metallic substrate. Depending on the substrate material, the operating distance may change.

Typical operating distance in installation orientation D

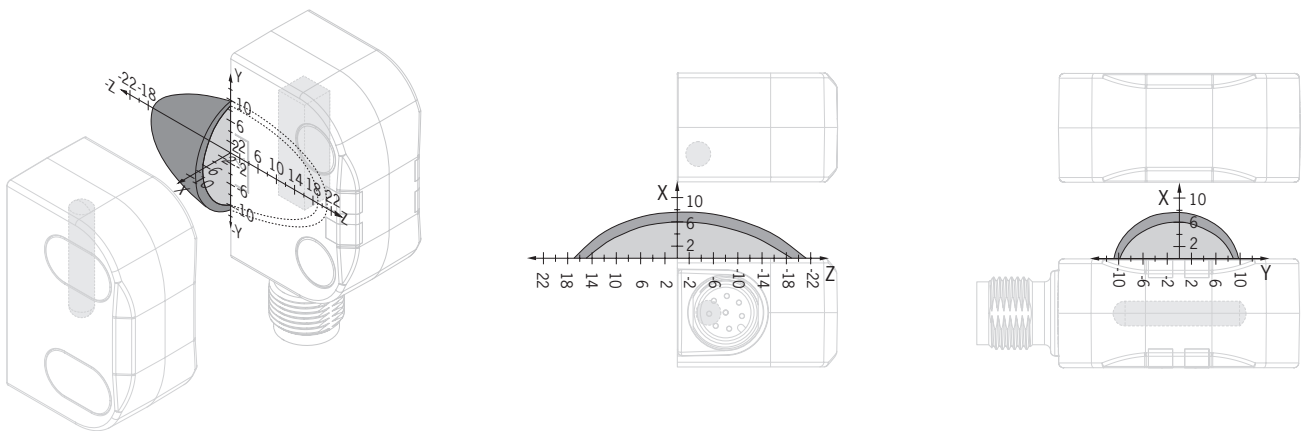

Switching distances for approach from x direction without center offset ($z, y = 0$)*

Parameter	Value			Unit
	min.	typ.	max.	
Switch-on distance	-	7	-	mm
Assured switch-on distance s_{a0}	2	-	-	
Switching hysteresis ¹⁾	1	2	-	
Assured switch-off distance s_{ar}	-	-	17	

* The data apply to mounting the actuator on a non-metallic substrate. Depending on the substrate material, the operating distance may change.

11.3. Technical data for actuator CES-A-BDN-06-158210

Parameter	Value			Unit
	min.	typ.	max.	
Housing material	Macromelt PA-based plastic			
Dimensions	26 x \varnothing 6			mm
Weight	0.005			kg
Ambient temperature	- 40	-	+ 70	°C
Degree of protection acc. to EN IEC 60529	IP65/IP67/IP69/IP69K 1)			
Installation orientation	Active face opposite read head			
Power supply	Inductive via read head			

1) With flush installation

11.3.1. Dimension drawing

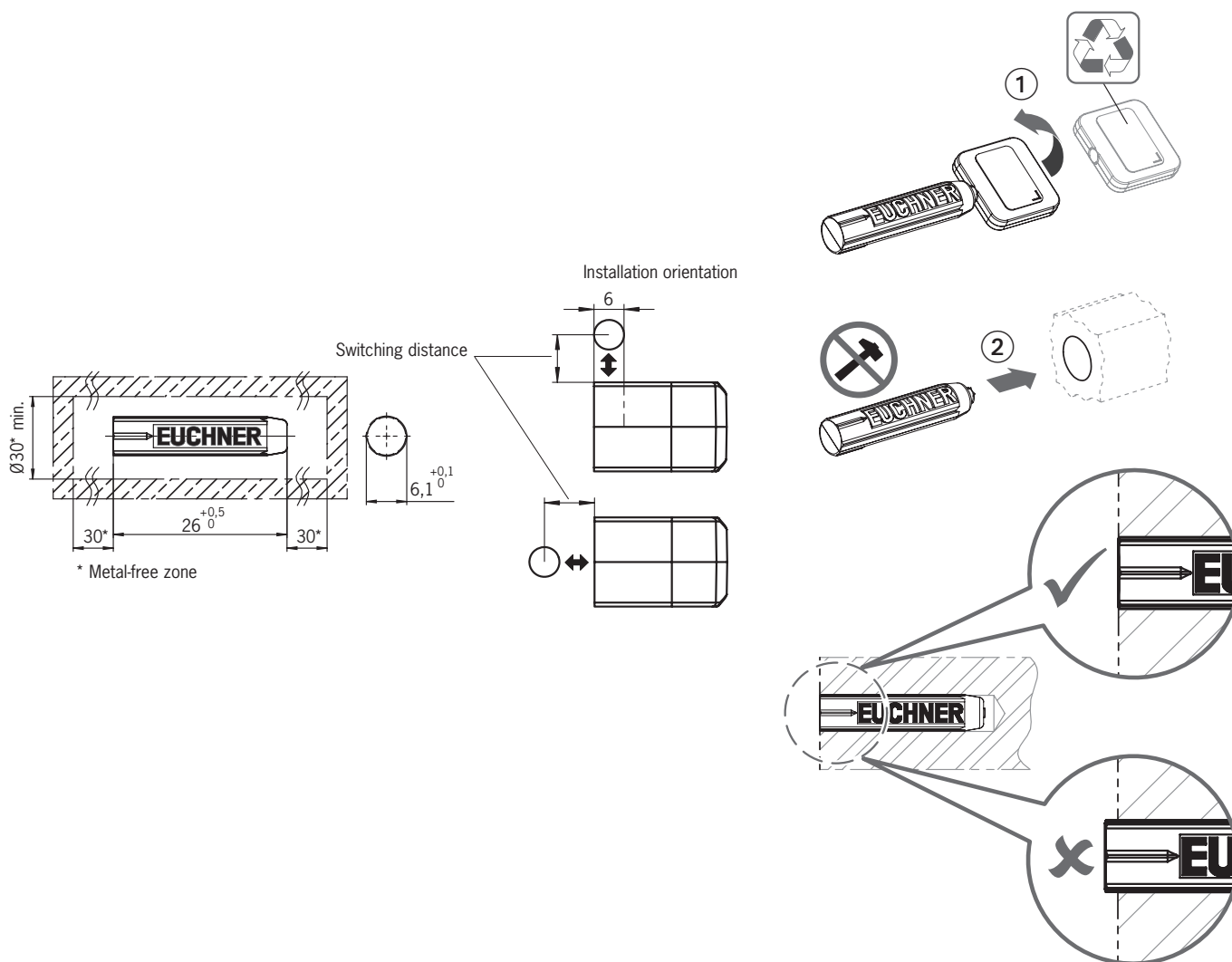

CAUTION

- › Do not mount at temperatures below 0 °C.
- › The actuator can be damaged during mounting.

11.3.2. Switching distances*

Operating distance for center offset $m = 0$

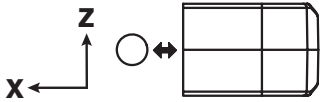
Installation orientation	Parameter	Value			Unit
		min.	typ.	max.	
A					
	Switch-on distance	-	16	-	mm
	Assured switch-on distance s_{a0}	13	-	-	
	Switching hysteresis	1	2	-	
	Assured switch-off distance s_{ar} - in x direction	-	-	24	

* The data apply to mounting the actuator in non-metallic surroundings. Depending on the surrounding material, the operating distance may change.

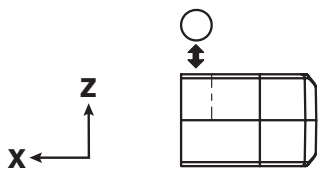
Installation orientation	Parameter	Value			Unit
		min.	typ.	max.	
C					
	Switch-on distance	-	11	-	mm
	Assured switch-on distance s_{a0}	6	-	-	
	Switching hysteresis	1	2	-	
	Assured switch-off distance s_{ar} - in x direction	-	-	21	

* The data apply to mounting the actuator in non-metallic surroundings. Depending on the surrounding material, the operating distance may change.

12. Ordering information and accessories



Tip!

Suitable accessories, e.g. cables or assembly material, can be found at www.euchner.com. To order, enter the order number of your item in the search box and open the item view. Accessories that can be combined with the item are listed in "Accessories."

13. Inspection and service



WARNING

Loss of the safety function because of damage to the device.

- › In case of damage, the entire device must be replaced.
- › Only accessories or spare parts that can be ordered from EUCHNER may be replaced.

Regular inspection of the following is necessary to ensure trouble-free long-term operation:

- › Check the switching function (see chapter 9.3. *Functional check on page 16*)
- › Check the secure mounting of the devices and the connections
- › Check for soiling

No servicing is required. Repairs to the device are only allowed to be made by the manufacturer.



NOTICE

The year of manufacture can be seen in the bottom right corner. The current version number in the format (VX.X.X) can also be found on the device.

14. Service

If service support is required, please contact:

EUCHNER GmbH + Co. KG
Kohlhammerstraße 16
70771 Leinfelden-Echterdingen

Service telephone:

+49 711 7597-500

E-mail:

support@euchner.de

Internet:

www.euchner.com

15. Declaration of conformity



EUCHNER

More than safety.

EU-Konformitätserklärung
EU declaration of conformity
Déclaration UE de conformité
Dichiarazione di conformità UE
Declaración UE de conformidad

Original DE
Translation EN
Traduction FR
Traduzione IT
Traducción ES

2510141 -02-07/19

Die nachfolgend aufgeführten Produkte sind konform mit den Anforderungen der folgenden Richtlinien (falls zutreffend):
The beneath listed products are in conformity with the requirements of the following directives (if applicable):
Les produits mentionnés ci-dessous sont conformes aux exigences imposées par les directives suivantes (si valable)
I prodotti sotto elencati sono conformi alle direttive sotto riportate (dove applicabili):
Los productos listados a continuación son conforme a los requisitos de las siguientes directivas (si fueran aplicables):

I:	Maschinenrichtlinie	2006/42/EG
	Machinery directive	2006/42/EC
	Directive Machines	2006/42/CE
	Direttiva Macchine	2006/42/CE
	Directiva de máquinas	2006/42/CE
II:	Funkanlagen-Richtlinie (RED)	2014/53/EU
	Radio equipment directive	2014/53/EU
	Directive équipement radioélectrique	2014/53/UE
	Direttiva apparecchiatura radio	2014/53/UE
	Directiva equipo radioeléctrico	2014/53/UE
III:	RoHS Richtlinie	2011/65/EU
	RoHS directive	2011/65/EU
	Directive de RoHS	2011/65/UE
	Direttiva RoHS	2011/65/UE
	Directiva RoHS	2011/65/UE

Die Schutzziele der Niederspannungsrichtlinie 2014/35/EU und EMV Richtlinie 2014/30/EU werden gemäß Artikel 3.1 der Funkanlagen-Richtlinie eingehalten.
The safety objectives of the Low-voltage directive 2014/35/EU and EMC Directive 2014/30/EU comply with article 3.1 of the Radio equipment directive.
Les objectifs de sécurité de la Directive basse tension 2014/35/UE et Directive de CEM 2014/30/UE sont conformes à l'article 3.1 de la Directive équipement radioélectrique.
Gli obiettivi di sicurezza della Direttiva bassa tensione 2014/35/UE e Direttiva CEM 2014/30/UE sono conformi a quanto riportato nell'articolo 3.1 della Direttiva apparecchiatura radio.
Los objetivos de seguridad de la Directiva de bajo voltaje 2014/35/UE y Directiva CEM 2014/30/UE cumplen con el artículo 3.1 de la Directiva equipo radioeléctrico.

Folgende Normen sind angewandt:
Following standards are used:
Les normes suivantes sont appliquées:
Vengono applicate le seguenti norme:
Se utilizan los siguientes estándares:

a: EN 60947-5-3:2013
b: EN ISO 14119:2013
c: EN ISO 13849-1:2015
d: EN 62061:2005 + Cor.:2010 + A1:2013 + A2:2015
e: EN 50364:2018
f: EN 300 330 V2.1.1
g: EN 50581:2012 (RoHS)

Bezeichnung der Bauteile Description of components Description des composants Descrizione dei componenti Descripción de componentes	Type Type Type Tipo Tipo	Richtlinie Directives Directive Direttiva Directivas	Normen Standards Normes Norme Estándares	Zertifikats-Nr. No. of certificate Número du certificat Número del certificado Número del certificado
Sicherheitsschalter Safety Switches Interrupteurs de sécurité Fincoorsa di sicurezza Interruptores de seguridad	CES-I-BR...C07...	I, II, III	a, b, c, d, e, f, g	Z10 18 04 40393 024
Betätiger Actuator Actionneur Azionatore Actuador	CES-A-B...	I, II, III	a, b, c, d, e, f, g	Z10 18 04 40393 024 Z10 040393 0031



EUCHNER

More than safety.

Die alleinige Verantwortung für die Ausstellung dieser Konformitätserklärung trägt der Hersteller:
This declaration of conformity is issued under the sole responsibility of the manufacturer:
La présente déclaration de conformité est établie sous la seule responsabilité du fabricant:
La presente dichiarazione di conformità è rilasciata sotto la responsabilità esclusiva del fabbricante:
La presente declaración de conformidad se expide bajo la exclusiva responsabilidad del fabricante:

EUCHNER GmbH + Co. KG
Kohlhammerstraße 16
70771 Leinfelden-Echterdingen
Germany

Leinfelden, Juli 2019

EUCHNER GmbH + Co. KG
Kohlhammerstraße 16
70771 Leinfelden-Echterdingen
Germany

i.A. Dipl.-Ing. Richard Holz
Leiter Elektronik-Entwicklung
Manager Electronic Development
Responsable Développement Electronique
Direttore Sviluppo Elettronica
Director de desarrollo electrónico

i.A. Dipl.-Ing. (FH) Duc Binh Nguyen
Dokumentationsbevollmächtigter
Documentation manager
Responsable documentation
Responsabilità della documentazione
Agente documenta

Euchner GmbH + Co. KG
Kohlhammerstraße 16
70771 Leinfelden-Echterdingen
info@euchner.de
www.euchner.com

Edition:
2528734-03-12/19
Title:
Operating Instructions Non-Contact Safety Switch
CES-IBP.-C07-...
(Translation of the original operating instructions)
Copyright:
© EUCHNER GmbH + Co. KG, 12/2019

Subject to technical modifications; no responsibility is accepted for the accuracy of this information.