

EUCHNER

Operating Instructions

Non-Contact Safety Switch
CES-A-.5 Unicode/Multicode

EN

Contents

1.	About this document	4
1.1.	Scope.....	4
1.2.	Target group	4
1.3.	Key to symbols.....	4
1.4.	Supplementary documents	4
2.	Correct use	5
3.	Description of the safety function	6
4.	Exclusion of liability and warranty	6
5.	General safety precautions	6
6.	Function	7
6.1.	Door monitoring output	7
6.2.	Switching states	7
6.3.	Block diagram	8
7.	Changing the approach direction	9
8.	Mounting	10
9.	Electrical connection	11
9.1.	Notes about c(UL)us.....	12
9.2.	Safety in case of faults.....	12
9.3.	Requirements for connecting cables.....	12
9.4.	Connector assignment of safety switch CES-A-5.....	13
9.5.	Correct connection	13
9.6.	Connection example	14
10.	Setup	15
10.1.	LED displays	15
10.2.	Teach-in function for actuator (only for unicode evaluation)	15
10.2.1.	Carrying out teach-in for first actuator (delivery state)	15
10.2.2.	Carrying out teach-in for a new actuator.....	16
10.3.	Functional check.....	16
11.	System status table	17

12.	Technical data	18
12.1.	Safety switch CES-A-.5	18
12.1.1.	Technical data for safety switch CES-A-.5	19
12.1.2.	Typical system times	20
12.2.	Actuator CES-A-BPA	21
12.2.1.	Technical data	21
12.2.2.	Typical actuating range	22
12.2.3.	Actuating range for center offset $m = 0$ ¹⁾	22
12.3.	Actuator CES-A-BBA/CES-A-BCA	23
12.3.1.	Technical data	23
12.3.2.	Typical actuating range	24
12.3.3.	Actuating range for center offset $m = 0$ ¹⁾	24
13.	Ordering information and accessories	25
14.	Inspection and service	25
15.	Service	25
16.	Declaration of conformity	25

1. About this document





1.1. Scope

These operating instructions apply to all CES-A-.5 of version V0.1.X. These operating instructions, the document *Safety information* and any available data sheet form the complete user information for your device.

1.2. Target group





Design engineers and installation planners for safety devices on machines, as well as setup and servicing staff possessing special expertise in handling safety components.

1.3. Key to symbols

Symbol/depiction	Meaning
	Printed document
	Document is available for download at www.euchner.com
 DANGER WARNING CAUTION	Safety precautions Danger of death or severe injuries Warning about possible injuries Caution slight injuries possible
 NOTICE Important!	Notice about possible device damage Important information
Tip	Useful information

1.4. Supplementary documents

The overall documentation for this device consists of the following documents:

Document title (document number)	Contents	
Safety information (2525460)	Basic safety information	
Operating instructions (2096580)	(this document)	
Declaration of conformity	Declaration of conformity	
Possibly available data sheet	Item-specific information about deviations or additions	
	Important! Always read all documents to gain a complete overview of safe installation, setup and use of the device. The documents can be downloaded from www.euchner.com . For this purpose, enter the document number or the order number for the device in the search box.	

2. Correct use

Safety switches series CES-A-.5 are interlocking devices without guard locking (type 4). The device meets the requirements according to EN IEC 60947-5-3. Devices with unicode evaluation possess a high coding level, devices with multicode evaluation possess a low coding level.

In combination with a movable guard and the machine control, this safety component prevents dangerous machine functions from occurring while the guard is open. A stop command is triggered if the guard is opened during the dangerous machine function.

This means:

- Starting commands that cause a dangerous machine function must become active only when the guard is closed.
- Opening the guard triggers a stop command.
- Closing a guard must not cause automatic starting of a dangerous machine function. A separate start command must be issued. For exceptions, refer to EN ISO 12100 or relevant C-standards.

Before the device is used, a risk assessment must be performed on the machine, e.g. in accordance with the following standards:

- EN ISO 13849-1
- EN ISO 12100
- IEC 62061

Correct use includes observing the relevant requirements for installation and operation, particularly based on the following standards:

- EN ISO 13849-1
- EN ISO 14119
- EN 60204-1

The safety switch is only allowed to be operated in conjunction with the intended EUCHNER CES actuators and the related connection components from EUCHNER. On the use of different actuators or other connection components, EUCHNER provides no warranty for safe function.



Important!

- The user is responsible for the proper integration of the device into a safe overall system. For this purpose, the overall system must be validated, e.g. in accordance with EN ISO 13849-2.
- It is only allowed to use components that are permissible in accordance with the table below.

Table 1: Possible combinations for CES components

Safety switch	Actuator			
	CES-A-BBA 071840	CES-A-BCA 088786	CES-A-BDA-20 084720	CES-A-BPA 098775
CES-A-C5E-01 077750	●	●	●	●
CES-A-C5H-01 091458	●	●	●	●
CES-A-W5H-01 097525	●	●	●	●

Key to symbols	●	Combination possible
		Combination not permissible

3. Description of the safety function

Devices from this series feature the following safety functions:

Monitoring of the guard position (interlocking device according to EN ISO 14119)

- › Safety function:
 - The safety outputs are switched off when the guard is open (see chapter 6.2. *Switching states on page 7*).
- › Safety characteristics: category, Performance Level, PFH_D (see chapter 12. *Technical data on page 18*).

4. Exclusion of liability and warranty

In case of failure to comply with the conditions for correct use stated above, or if the safety regulations are not followed, or if any servicing is not performed as required, liability will be excluded and the warranty void.

5. General safety precautions

Safety switches fulfill personnel protection functions. Incorrect installation or tampering can lead to fatal injuries to personnel.

Check the safe function of the safeguard particularly

- › after any setup work
- › after the replacement of a system component
- › after an extended period without use
- › after every fault

Independent of these checks, the safe function of the safeguard should be checked at suitable intervals as part of the maintenance schedule.



WARNING

Danger to life due to improper installation or due to bypassing (tampering). Safety components fulfill a personnel protection function.

- › Safety components must not be bypassed, turned away, removed or otherwise rendered ineffective. On this topic pay attention in particular to the measures for reducing the possibility of bypassing according to EN ISO 14119:2013, section 7.
- › The switching operation must be triggered only by actuators designated for this purpose.
- › Prevent bypassing by means of replacement actuators (only for multicode evaluation). For this purpose, restrict access to actuators and to keys for releases, for example.
- › Mounting, electrical connection and setup only by authorized personnel possessing the following knowledge:
 - specialist knowledge in handling safety components
 - knowledge about the applicable EMC regulations
 - knowledge about the applicable regulations on operational safety and accident prevention.



Important!

Prior to use, read the operating instructions and keep these in a safe place. Ensure the operating instructions are always available during mounting, setup and servicing. For this reason you should archive a printed copy of the operating instructions. You can download the operating instructions from www.euchner.com.

6. Function

The safety switch monitors the position of movable guards. The safety outputs are switched on/off when the actuator is moved to/removed from the actuating range.

The system consists of the following components: coded actuator (transponder with high coding level) and switch.

Whether the device learns the complete actuator code (unicode) or not (multicode) depends on the respective version.

- **Devices with unicode evaluation:** The actuator must be assigned to the safety switch by a teach-in operation so that it is detected by the system. This unambiguous assignment ensures a particularly high level of protection against tampering. The system thus possesses a high coding level.
- **Devices with multicode evaluation:** Unlike systems with unicode evaluation, on multicode devices a specific code is not requested but instead it is only checked whether the actuator is of a type that can be detected by the system (multicode detection). There is no exact comparison of the actuator code with the taught-in code in the safety switch (unicode evaluation). The system possesses a low coding level.

When the guard is closed, the actuator is moved towards the safety switch. When the operating distance is reached, power is supplied to the actuator by the switch and data are transferred.

If a permissible code is detected, the safety outputs are switched on.

The safety outputs are switched off when the guard is opened.

In the event of a fault in the safety switch, the safety outputs are switched off and the DIA LED illuminates red. The occurrence of faults is detected at the latest on the next demand to close the safety outputs (e.g. on starting).

6.1. Door monitoring output

The door monitoring output is switched on as soon as a valid actuator is detected in the actuating range.

6.2. Switching states

The detailed switching states for your switch can be found in the system status table. All safety outputs, monitoring outputs and display LEDs are described there.

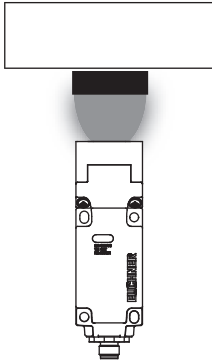
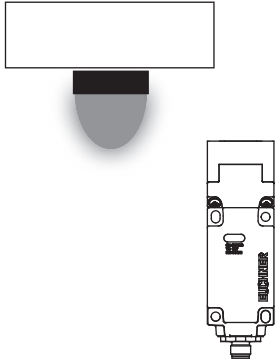
	Guard closed (actuator in the actuating range and permissible code detected)	Guard open (actuator not in the actuating range)
		
Safety outputs LA and LB	on	off
Monitoring output OUT	on	off

6.3. Block diagram

Coded actuator

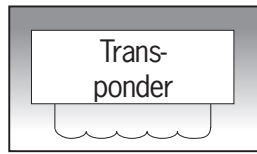

Read head with evaluation unit CES-A-.5

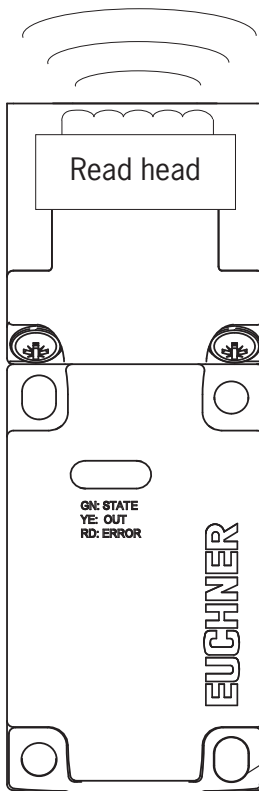

Housing:
118 x 40 x 40 mm

Connection:
M 12x1
8-pin, screened

Output circuit:

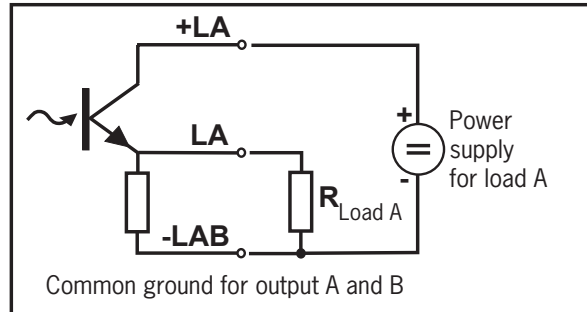

Pin assignment:

Pin	Core color	Function
1	WH/white	0V
2	BN/brown	+ U _B
3	GN/green	LA
4	YE/yellow	LB
5	GY/gray	OUT
6	PK/pink	+LA
7	BU/blue	-LAB
8	RD/red	+LB

Screen bonding clamp

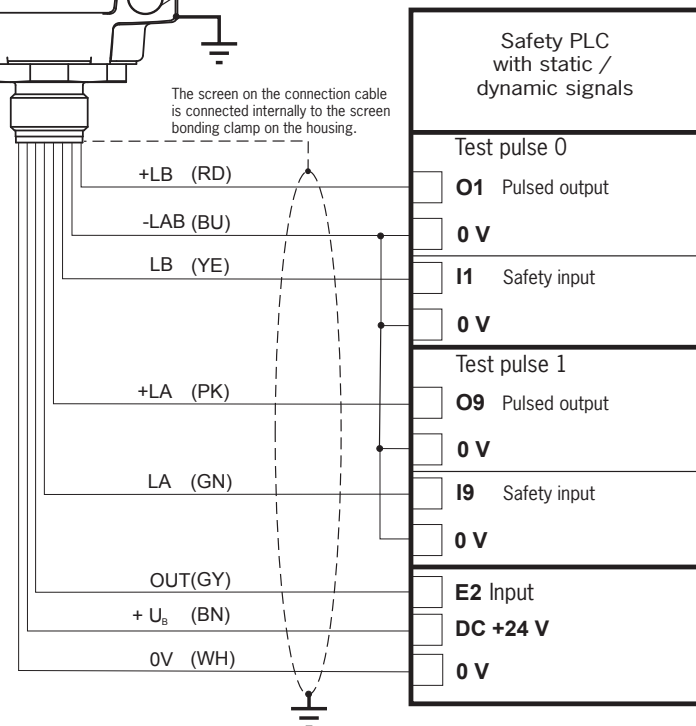

Connection example with safety PLC PSS 3056 (PILZ)

7. Changing the approach direction



NOTICE

Risk of damage to equipment as a result of trapped cables.

► Make sure that the cables are not trapped or torn off when the approach direction is changed.

The active face of the read head can be adjusted in 5 directions. It is marked by the red face.

1. Unscrew the screws on the fastening bracket.
2. Pull the read head off the fastening bracket and tilt the read head by 90° (arrow 2).
- The active face is now pointing downward.
3. Turn the read head by 180° (arrow 3).
4. Re-tighten the screws for the read head on the fastening bracket. Tightening torque 0.6 Nm.

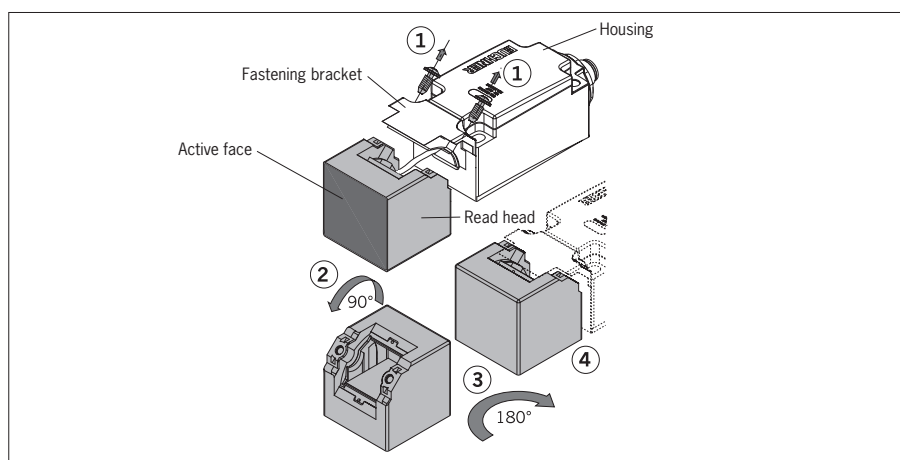

5. Remove the clip from the underside of the housing to change the lateral approach direction.
6. Pull the read head off the housing and turn it in 90° steps in the desired approach direction.
7. Fit the read head to the housing and re-fit the clip.

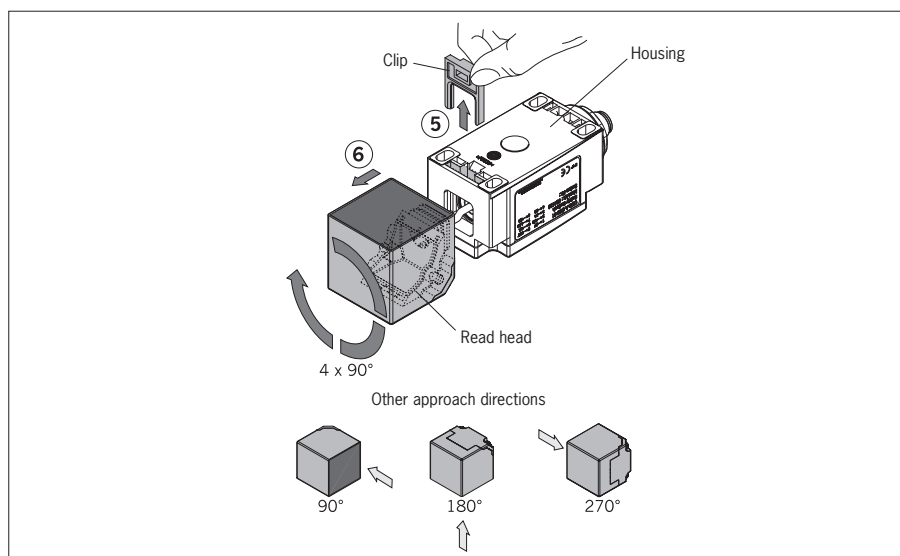

8. Mounting



CAUTION

Safety switches must not be bypassed (bridging of contacts), turned away, removed or otherwise rendered ineffective.

- › Observe EN ISO 14119:2013, section 7, for information about reducing the possibilities for bypassing an interlocking device.



NOTICE

Risk of damage to equipment and malfunctions as a result of incorrect installation.

- › Safety switches and actuators must not be used as an end stop.
- › Observe EN ISO 14119:2013, sections 5.2 and 5.3, for information about mounting the safety switch and the actuator.
- › From the assured release distance S_{ar} , the safety outputs are safely shut down.
- › When mounting several safety switches/actuators, observe the stipulated minimum distance to avoid mutual interference.

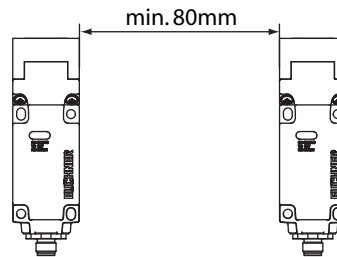

- › If the actuator is installed flush, the operating distances change as a function of the installation depth and the guard material.

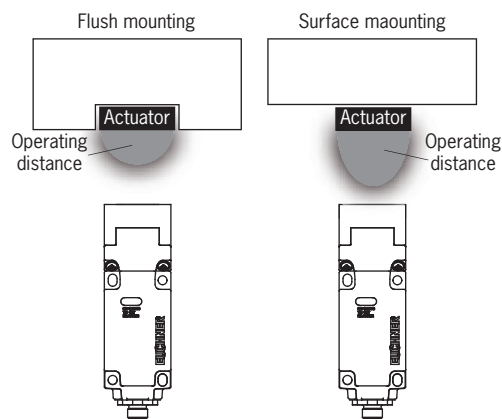

Note the following points:

- › Actuator and safety switch must be easily accessible for inspection and replacement.
- › Actuator and safety switch must be fitted so that
 - the front faces are at the minimum operating distances $0.8 \times S_{a0}$ or closer when the guard is closed. To avoid entering the area of possible side lobes, a minimum distance is to be maintained in case of a side approach direction. See chapter 12. *Technical data*, section *Typical actuating range* for the related actuator.
 - when the guard is open up to the distance S_{ar} (assured release distance), a hazard is excluded.
 - the actuator is positively mounted on the guard, e.g. by using the safety screws included.
 - they cannot be removed or tampered with using simple means.
- › Pay attention to the maximum tightening torque of 1 Nm for mounting the safety switch and actuator. For actuators made of PE-HD, the maximum tightening torque is only 0.5 Nm.

9. Electrical connection



WARNING

Loss of the safety function due to incorrect connection.

- › Not suitable for safety relays that implement short circuit monitoring with different potentials (0 V/24 V). The voltage at +LA/+LB must correspond to the information in the technical data.

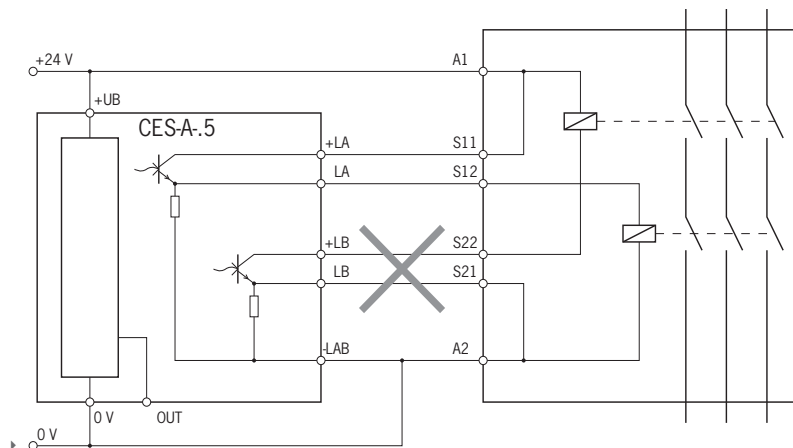

WARNING

In the event of a fault, loss of the safety function due to incorrect connection.

- › To ensure safety, both safety outputs must always be evaluated.
- › Monitoring outputs must not be used as safety outputs.
- › Lay the connecting cables with protection to prevent the risk of short circuits.



CAUTION

Risk of damage to equipment or malfunctions as a result of incorrect connection.

- › The inputs on a connected evaluation unit must be positive switching, as the two outputs on the safety switch deliver a level of +24 V in the switched-on state.
- › All the electrical connections must either be isolated from the mains supply by a safety transformer according to IEC 61558-2-6 with limited output voltage in the event of a fault, or by other equivalent insulation measures (PELV).
- › All electrical outputs must have an adequate protective circuit for inductive loads. The outputs must be protected with a free-wheeling diode for this purpose. RC interference suppression units must not be used.
- › Power devices which are a powerful source of interference must be installed in a separate location away from the input and output circuits for signal processing. The cable routing for safety circuits should be as far away as possible from the cables of the power circuits.
- › To avoid EMC interference, the physical environmental and operating conditions at the installation site of the device must comply with the requirements according to the standard EN 60204-1.
- › Please pay attention to any interference fields from devices such as frequency converters or induction heating systems. Observe the EMC instructions in the manuals from the respective manufacturer.





Important!

- › If the device does not appear to function when operating voltage is applied (e.g. green STATE LED does not illuminate or flash), the safety switch must be returned unopened to the manufacturer.
- › The device is fully encapsulated, it is therefore not possible to remove the lid from the housing.

9.1. Notes about



Important!

- › For use and application as per the requirements of  1) a power supply with the feature “for use in Class 2 circuits” must be used.
Alternative solutions must comply with the following requirements:
 - This device shall be used with a suitable isolating source in conjunction with a fuse in accordance with UL 248. This fuse should be designed for max. 3.3 A and should be integrated into the 30 V DC voltage section.
- › For use and application as per the requirements of  1) a connecting cable listed under the UL category code CYJV2 or CYJV must be used.

1) Note on the scope of the UL approval: the devices have been tested as per the requirements of UL508 and CSA/ C22.2 no. 14 (protection against electric shock and fire).

9.2. Safety in case of faults

- › The operating voltage U_B is reverse polarity protected.
- › The contacts LA/LB and -LA/-LB are short circuit-proof, but they are not reverse polarity protected.
- › A short circuit between LA and LB can be detected only by external pulsing.
- › A short circuit in the cable can be excluded by laying the cable with protection.
- › The device meets the necessary EMC regulations even with an unscreened connecting cable. For applications that are particularly sensitive to interference, a screened cable can be connected to the shield spring. This can be electrically connected to the machine ground via the fixing screws. The shield at the open end of the cable must also be connected electrically to the machine ground.

9.3. Requirements for connecting cables



CAUTION

- Risk of damage to equipment or malfunctions as a result of incorrect connecting cables.
- › Use connection components and connecting cables from EUCHNER.
 - › On the use of other connection components, the requirements in the following table apply. EUCHNER provides no warranty for safe function in case of failure to comply with these requirements.

Observe the following requirements with respect to the connecting cables:

Table 2: Voltage drop as a function of switching current and cable length (examples)

Switching current [mA]	Cable length "l" [m]	Voltage drop Output [V]	Max. voltage drop Cable [V]	Max. voltage drop Total [V]
6 (safety control system with pulsed signals)	1 - 100	1.4	0.1	1.5
	101 - 300	1.4	0.4	1.8
50 (safety relay)	1 - 15	1.5	0.2	1.7
	16 - 50	1.5	0.5	2.0
	51 - 100	1.5	1.0	2.5
	101 - 300	1.5	3.0	4.5
400 (e.g. small contactor)	1 - 15	1.7	1.2	2.9
	16 - 50	1.7	4.0	5.7
	51 - 100	1.7	8.0	9.7
	101 - 300	1.7	-	-

9.4. Connector assignment of safety switch CES-A-.5

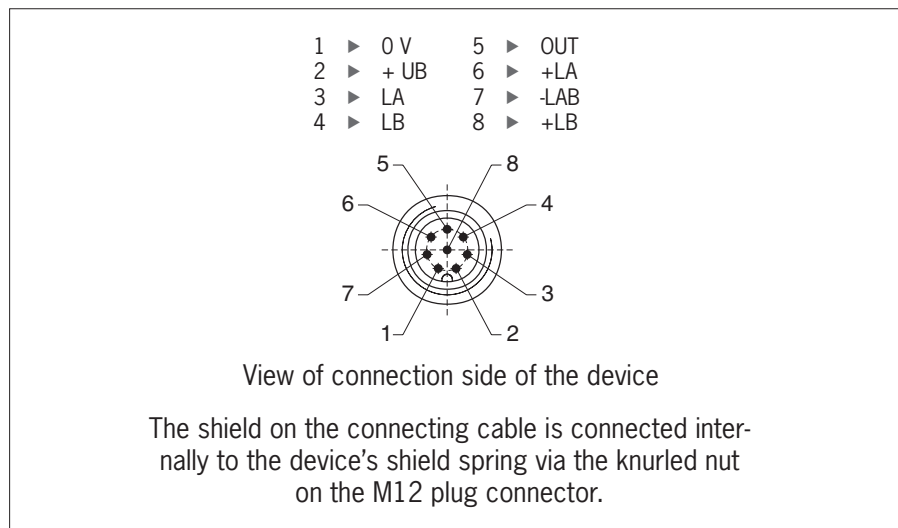

Fig. 1: Connector assignment of safety switch CES-A-.5

9.5. Correct connection



WARNING

In the event of a fault, loss of the safety function due to incorrect connection.

- ▶ To ensure safety, both safety outputs (LA and LB) must always be evaluated.
- ▶ To achieve category 3/4 according to EN ISO 13849-1, it is necessary to monitor the downstream contactors.

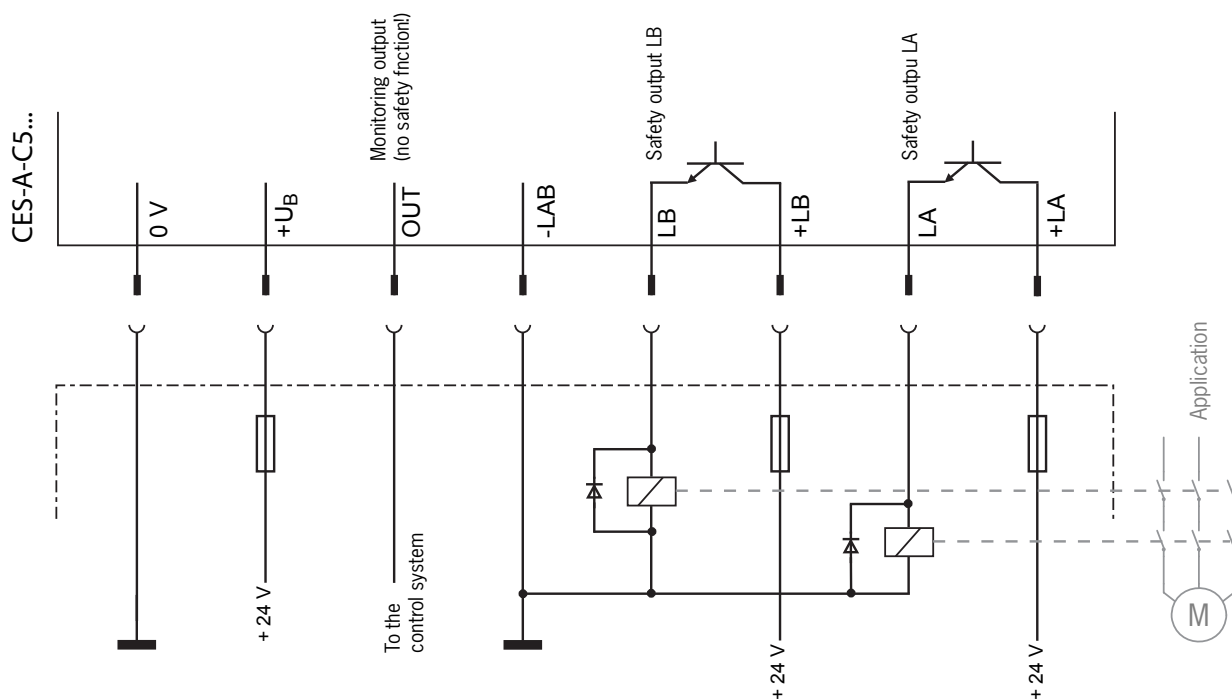

9.6. Connection example



Important!

- › To achieve category 4 according to EN ISO 13849-1, it is necessary to monitor the downstream contactors (not shown here).
- › The example shows only an excerpt that is relevant for the connection of the CES system. The example illustrated here does not show complete system planning. The user is responsible for safe integration into the overall system.

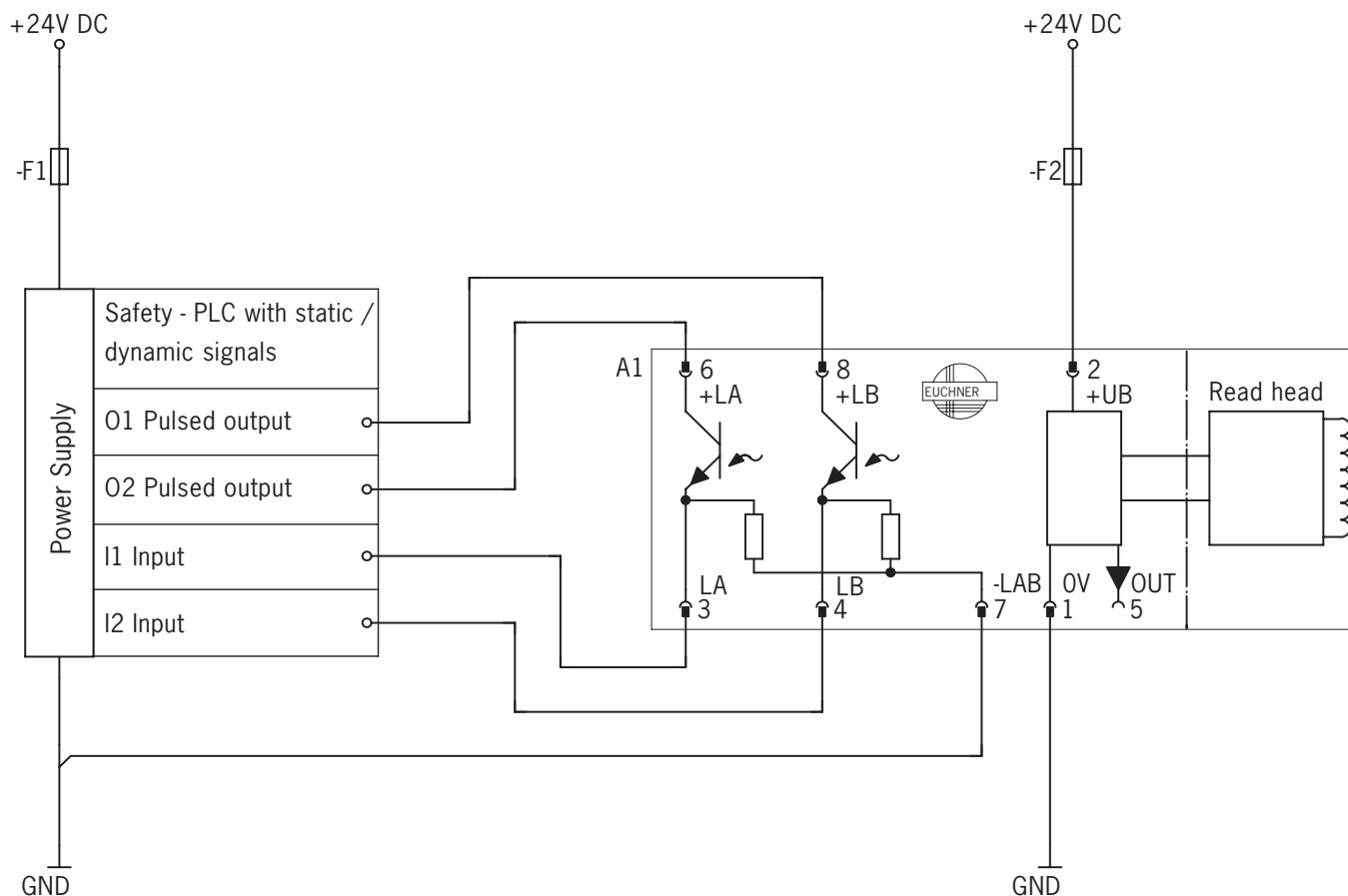





Fig. 2: Connection example CES-A-5

10. Setup

10.1. LED displays

LED	Color	State	Meaning
STATE	green	illuminated 	Normal operation
		flashing 	- Teach-in operation (for further signal function, see chapter 11. System status table on page 17)
OUT/ERROR	yellow	illuminated 	Valid actuator detected
	red	illuminated 	- Internal electronics fault - Invalid teach-in operation (for further signal function, see chapter 11. System status table on page 17)

10.2. Teach-in function for actuator (only for unicode evaluation)

The actuator must be assigned to the evaluation unit using a teach-in function before the system forms a functional unit.

During the teach-in operation the safety outputs are open and the door monitoring output is LOW. The system is in the safe state.



Important!

- › During the teach-in operation the following conditions must be met:
 - No state change, e.g. opening of a safety door.
 - The power supply must not be switched off.
- › If these conditions are not met, the evaluation unit switches to the safe fault state (ERROR LED illuminates) and signals this operating fault with the STATE LED.
- › The number of teach-in operations on one evaluation unit is limited to a maximum of 8.
- › The evaluation unit can be operated only with the last actuator taught-in.
- › An actuator that has not been subjected to teach-in will not be detected by the related read head.
- › When the evaluation unit is switched on (operating voltage is applied), the STATE LED signals the number of possible remaining teach-in operations (see system status table).
- › Also after the 8th teach-in operation or if an "old" actuator is placed against the read head, the system automatically switches to the teach-in mode. In both cases, a teach-in operation with a duration of 60 seconds is started; however, the last actuator code remains active in the memory (see system status table) – a new code is not taught-in.

10.2.1. Carrying out teach-in for first actuator (delivery state)

To trigger the first teach-in operation, the user must perform the following actions in the stipulated order:

1. Start teach-in operation
 - Switch on operating voltage (STATE LED flashes at approx. 4 Hz)
 - Close door to be monitored (the actuator must be in the actuating range of the read head)
 - Teach-in operation starts (STATE LED flashes at approx. 1 Hz)
 - Wait for acknowledgment of the teach-in operation (STATE LED goes out after approx. 60 seconds)
2. End teach-in operation
 - Interrupt operating voltage for at least 3 seconds (code for the actuator taught-in is activated)
3. Check safeguard for effectiveness

10.2.2. Carrying out teach-in for a new actuator

A maximum of 8 teach-in operations can be performed. The number of already completed teach-in operations is signaled by the flashing sequence of the STATE LED each time the power supply is connected (see 11. System status table on page 17, area Status indication).

Faulty actuators can be replaced. Then a complete teach-in operation must be performed as per this section.

To trigger a further teach-in operation, the user must perform the following actions in the stipulated order:

1. Start teach-in operation
 - Switch on operating voltage
 - Close door to be monitored (the new actuator must be in the actuating range of the read head)
 - Teach-in operation starts (STATE LED flashes at approx. 1 Hz)
 - Wait for acknowledgment of the teach-in operation (STATE LED goes out after approx. 60 seconds)
2. End teach-in operation
 - Interrupt operating voltage for at least 3 seconds (code for the new actuator taught-in is activated)

The newly taught-in actuator is saved and the old actuator deactivated.

3. Check safeguard for effectiveness

10.3. Functional check

After installation and any fault, the safety function must be fully checked. Proceed as follows:



WARNING

Danger of fatal injury as a result of faults in installation and functional check.

- › Before carrying out the functional check, make sure that there are no persons in the danger zone.
- › Observe the valid accident prevention regulations.

1. Switch on operating voltage.
 - The safety switch carries out a self-test.
The green STATE LED flashes up to 3 times.
The STATE LED then illuminates continuously.
The OUT and ERROR LEDs do not light up.
2. Close all guards.
 - The machine must not start automatically.
 - The green STATE LED and the yellow OUT LED light up continuously.
3. Enable operation in the control system.
4. Open the guard.
 - The machine must switch off and it must not be possible to start it as long as the guard is open.
 - The green STATE LED illuminates continuously; the OUT and ERROR LEDs do not illuminate.

Repeat steps 2 ... 4 separately for each guard.

11. System status table

Operating mode	Actuator/door position	Safety outputs LA and LB	PLC	LED indicator Output			State
			Output	STATE (green)	OUT/ERROR (yellow)	OUT/ERROR (red)	
			OUT (status signal)				
Normal operation	closed	on	1				Normal operation, door closed
	open	off	0				Normal operation, door open
Teach-in operation (only unicode)	open	off	0	4 Hz			Initial setup after delivery, ready for first teach-in operation
	closed	off	0	1 Hz (60 s)			Teach-in operation
	closed	off	0				Positive acknowledgment of completion of teach-in operation To activate the actuator code from the teach-in operation in the evaluation unit, the operating voltage must then be switched off at the evaluation unit for min. 3 seconds.
Status indication (only unicode)	X	off	0	3 x +			Indication after 1st to 5th teach-in operations
	X	off	0	2 x +			Indication of the remaining teach-in operations after the 6th teach-in operation
	X	off	0	1 x +			Indication of the remaining teach-in operations after the 7th teach-in operation
	X	off	0				Device cannot perform any further teach-in operation
Fault display	X	off	0				Internal component failure or excessively high interference (EMC) or short circuit/external power at the LA/LB safety output
Operating fault (only unicode)	closed	off	0	1 x			Incorrect 9th teach-in operation (only unicode)
	closed	off	0	2 x			Incorrect teach-in operation for an old actuator (only unicode)
	closed	off	0	3 x			Negative acknowledgment for teach-in operation. Actuator was held in front of the read head for less than 60 s

Key to symbols	N	0 V or not connected
	1	24 V
	0	0 V
		LED not illuminated
		LED illuminated
	15 Hz (8 s)	LED flashes for 8 seconds at 15 Hz
	3 x +	LED flashes three times and then illuminates continuously
	3 x	LED flashes three times, and this is then repeated
X	Any state	

After the cause has been remedied, faults can generally be reset by opening and closing the guard. If the fault is still displayed afterward, briefly interrupt the power supply. Please contact the manufacturer if the fault could not be reset after restarting.



Important!

If you do not find the displayed device status in the system status table, this indicates an internal device fault. In this case, you should contact the manufacturer.

12. Technical data



NOTICE

If a data sheet is available for the product, the information on the data sheet applies.

12.1. Safety switch CES-A-.5

- › Read head and evaluation unit integrated in the normal housing
- › Semiconductor output
- › M12 plug connector

Dimension drawing

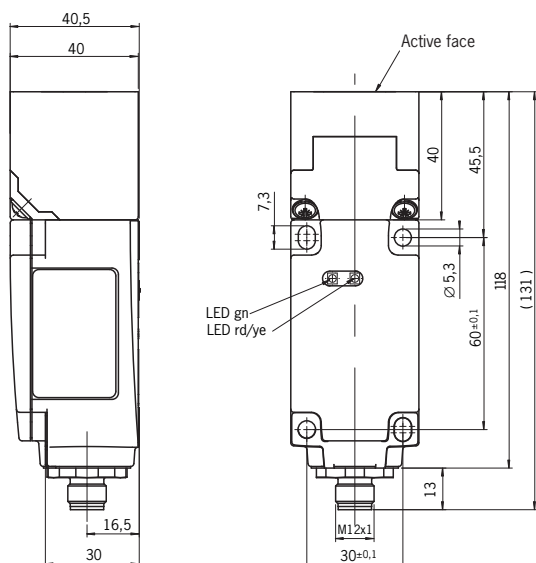

Switching characteristics

- › 2 safety outputs (semiconductor outputs)
- › 1 door monitoring output (semiconductor output, not a safety output)

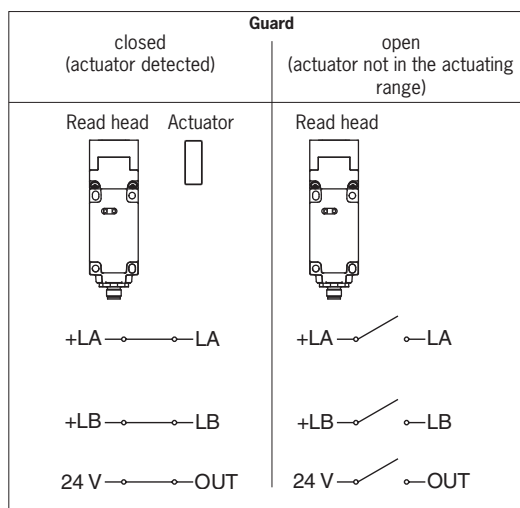

12.1.1. Technical data for safety switch CES-A-.5

Parameter	Value			Unit
	min.	typ.	max.	
Housing material	PBT GF30			
Dimensions	Acc. to EN 60947-5-2			mm
Weight	0.4			kg
Ambient temperature at $U_B = 24$ V DC	-20	-	+55	°C
Degree of protection	IP65/IP67			
Degree of contamination	3			
Rated insulation voltage U_i	-	300 ¹⁾	-	V
Rated impulse withstand voltage U_{imp}	-	1.5	-	kV
Rated conditional short-circuit current	100			A
Shock and vibration resistance	Acc. to EN 60947-5-3			
Installation orientation	Any			
Connection	M12 plug connector, 8-pin; shield can be connected			
Operating voltage U_B (regulated, residual ripple < 5%)	18	24	27	V DC
The following applies to the approval acc. to UL	Operation only with UL Class 2 power supply or equivalent measures			
Current consumption		80		mA
Switching load acc. to UL	max. DC 24 V, Class 2			
External fuse (operating voltage U_B)	0.25	-	8	A
Power supply for output load U(+LA)/U(+LB)	18	24	27	V DC
Safety outputs (LA/LB, 2 semiconductor outputs, p-switching, short circuit-proof, electrically decoupled)				
- Output voltage U(LA)/U(LB) ²⁾				
HIGH U(LA)	U(+LA) - 1.5	-	U(+LA)	V DC
HIGH U(LB)	U(+LB) - 1.5	-	U(+LB)	
LOW U(LA)/U(LB)	0	-	1	
Switching current per safety output	1	-	400	mA
External fuse (U(+LA)/U(+LB), safety circuit)	0.4 A medium slow-blow			
Utilization category	DC-13 24 V 400 mA			
Monitoring output (OUT, semiconductor output, p-switching, short circuit-proof)				
- Output voltage	$0.8 \times U_B$	-	U_B	V DC
- Output current	-	-	20	mA
Risk time ³⁾	-	-	180	ms
Discrepancy time	-	-	120	ms
Ready delay ⁴⁾	-	-	3	s
Dwell time ⁵⁾	0.5	-	-	s
Switching frequency	-	-	1	Hz
Repeat accuracy R acc. to EN IEC 60947-5-2	-	-	10	%
Mounting distance between 2 read heads or 2 actuators	80	-	-	mm
EMC protection requirements	Acc. to EN 60947-5-3			
LED displays	STATE	LED green: Normal operation Flashing: Teach-in operation		
	OUT/ERROR	LED yellow: Actuator detected		
	OUT/ERROR	LED red: - EMC interference - Internal electronics fault - Invalid teach-in operation		
Reliability values acc. to EN ISO 13849-1 ⁶⁾	CES-A-.5E-...	CES-A-.5H-...		
Category	3	4		
Performance Level (PL)	PL e	PL e		
PFH_D	4.29×10^{-8} / h	3.7×10^{-9} / h		
Mission time	20	20	years	
Diagnostic coverage DC	90	99	%	

1) Tested by employers' liability insurance association up to 75 V.

2) Values at a switching current of 50 mA without taking into account the cable lengths.

3) Maximum OFF time for the safety outputs following removal of the actuator.

4) After the operating voltage is switched on, the semiconductor outputs are switched off and the monitoring outputs are set LOW during the ready delay.

5) The dwell time of an actuator inside and outside the actuating range must be at least 0.5 s to ensure safe detection of internal faults in the evaluation unit (self-monitoring).

6) Refer to the declaration of conformity in chapter 16 for the issue date.

12.1.2. Typical system times

Please refer to the technical data for the exact values.

Ready delay: After switch-on, the device carries out a self-test. The system is ready for operation only after this time.

Turn-on time of safety outputs: The max. reaction time t_{on} is the time from the moment when the actuator is in the actuating range to the moment when the safety outputs switch on. This time corresponds to the risk time.

Risk time according to EN 60947-5-3: If an actuator moves outside the actuating range, the safety outputs (LA and LB) are deactivated at the latest after the risk time.

Discrepancy time: The safety outputs (LA and LB) switch with a slight time offset. They have the same signal state no later than after the discrepancy time.

12.2. Actuator CES-A-BPA

› Cube-shaped design 40 x 40 mm

Dimension drawing for CES-A-BPA

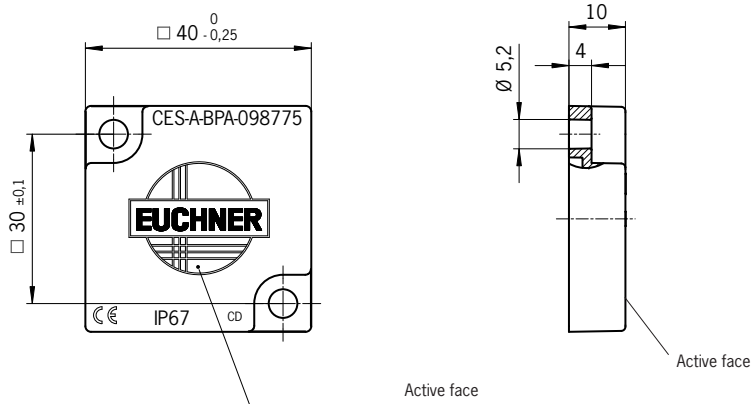

2 safety screws M4 x 14
included

12.2.1. Technical data

Parameter	Value			Unit
	min.	typ.	max.	
Housing material	PBT GF30			
Dimensions	40 x 40 x 10			mm
Weight	0.025			kg
Ambient temperature	-25	-	+70	°C
Degree of protection	IP67/IP69K			
Installation orientation	Active face opposite read head			
Power supply	Inductive via read head			

12.2.2. Typical actuating range

Only in conjunction with actuator CES-A-BPA on surface mounting.

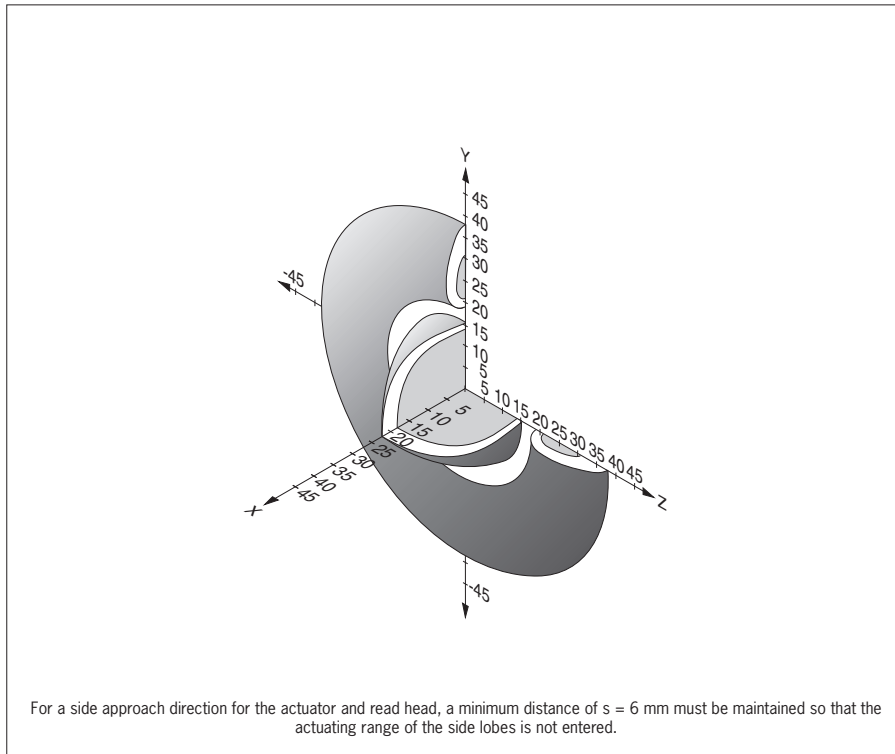

12.2.3. Actuating range for center offset $m = 0$ 1)

Parameter	Value			Unit
	min.	typ.	max.	
Operating distance	-	22 ¹⁾	-	mm
Assured operating distance S_{a0}	15	-	-	
Switching hysteresis	1	2	-	
Assured release distance S_{ar}	-	-	58	

1) On surface mounting on aluminum; the typical operating distances increase to 30 mm in a non-metallic environment.

12.3. Actuator CES-A-BBA/CES-A-BCA

- › Cube-shaped design 42 x 25 mm
- › CES-A-BCA suitable for use in aggressive media (e.g. acids, alkalis)
- › In combination with read head CES-A-LNA.../CES-A-LCA...

Dimension drawing for CES-A-BBA

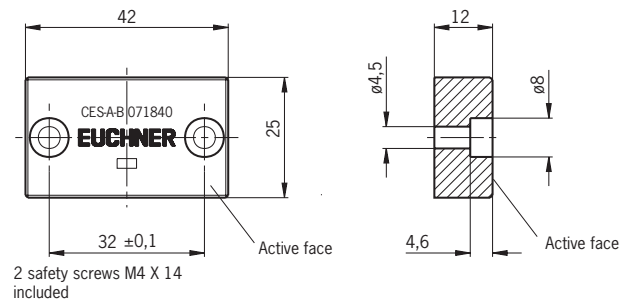

Dimension drawing for CES-A-BCA

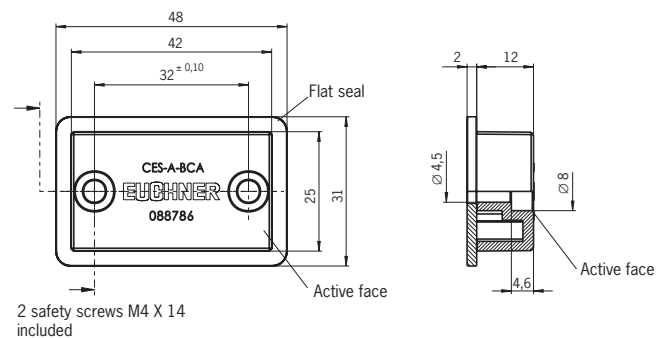

NOTICE

CES-A-BCA: The flat seal provided must be used during assembly.

12.3.1. Technical data

Parameter	Value			Unit
	min.	typ.	max.	
Housing material	Fortron, reinforced thermoplastic, fully encapsulated			
- CES-A-BBA	PE-HD plastic without reinforcement, fully encapsulated			
- CES-A-BCA	Fluororubber 75 FPM 4100			
Flat seal material (CES-A-BCA only)	Fluororubber 75 FPM 4100			
Dimensions	42 x 25 x 12			mm
Weight	0.02			kg
Ambient temperature				
- CES-A-BBA	-25	-	+70	°C
- CES-A-BCA	-25	-	+50	
Degree of protection	IP67/IP69K			
Installation orientation	Active face opposite read head			
Power supply	Inductive via read head			

12.3.2. Typical actuating range

Only in combination with actuator CES-A-BBA or CES-A-BCA.

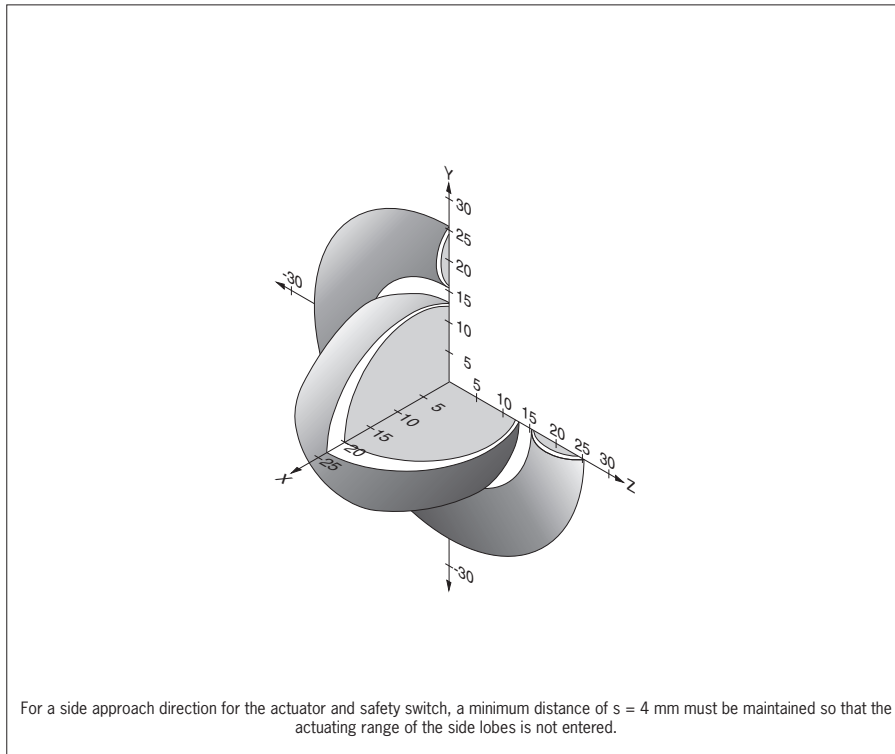

12.3.3. Actuating range for center offset $m = 0$ 1)

Parameter	Value			Unit
	min.	typ.	max.	
Assured operating distance S_{ao}	18	-	-	mm
Operating distance	-	20	-	
Switching hysteresis	2	3	-	
Assured release distance S_{ar}	-	-	40	

1) The values apply to surface mounting of the actuator.

13. Ordering information and accessories



Tip!

Suitable accessories, e.g. cables or assembly material, can be found at www.euchner.com. To order, enter the order number of your item in the search box and open the item view. Accessories that can be combined with the item are listed in "Accessories."

14. Inspection and service



WARNING

Loss of the safety function because of damage to the device.

- › In case of damage, the entire device must be replaced.
- › Only accessories or spare parts that can be ordered from EUCHNER may be replaced.

Regular inspection of the following is necessary to ensure trouble-free long-term operation:

- › Check the switching function (see chapter 10.3. *Functional check on page 16*)
- › Check the secure mounting of the devices and the connections
- › Check for contamination

No servicing is required. Repairs to the device are only allowed to be made by the manufacturer.



NOTICE

The year of manufacture can be seen in the lower right corner of the type label. The current version number in the format (VX.X.X) can also be found on the device.

15. Service

If servicing is required, please contact:

EUCHNER GmbH + Co. KG
Kohlhammerstraße 16
70771 Leinfelden-Echterdingen

Service telephone:
+49 711 7597-500

E-mail:
support@euchner.de

Internet:
www.euchner.com

16. Declaration of conformity

The declaration of conformity is part of the operating instructions.

The complete EU declaration of conformity can also be found at www.euchner.com. Enter the order number of your device in the search box. The document is available under *Downloads*.

Euchner GmbH + Co. KG
Kohlhammerstraße 16
70771 Leinfelden-Echterdingen
info@euchner.de
www.euchner.com

Edition:
2096580-16-11/22
Title:
Operating Instructions Non-Contact Safety Switch CES-A.5
(translation of the original operating instructions)
Copyright:
© EUCHNER GmbH + Co. KG, 11/2022

Subject to technical modifications; no responsibility is accepted for the accuracy of this information.