

EUCHNER

Operating Instructions

**Non-Contact Safety Switch
CES-I-IO-.-C07 (High/Low Coding Level)**

EN

Contents

1.	About this document	4
1.1.	Scope.....	4
1.1.1.	Type label.....	4
1.2.	Target group	4
1.3.	Key to symbols.....	4
1.4.	Supplementary documents	5
2.	Correct use	6
2.1.	Notes on the EU Data Act.....	7
3.	Description of the safety function	7
4.	Exclusion of liability and warranty	7
5.	General safety precautions	8
6.	Function	9
6.1.	Limit-range monitoring	9
6.2.	Safe position status bit.....	9
6.3.	Actuator status bit	9
6.4.	Diagnostics status bit.....	9
6.5.	Evaluation of the actuator.....	10
6.5.1.	Actuator type 01 – general actuator, high coding level.....	11
6.5.2.	Actuator type 04 – actuator set, high coding level	11
6.5.3.	Actuator type 05 – actuator with actuator number, low coding level	11
6.6.	Switching states	11
7.	Mounting	12
8.	Electrical connection	14
8.1.	Connector assignment, safety switch CES-I-IO-.-C07 with plug connector M12, 5-pin	14
8.2.	Notes about UL	14
9.	IO-Link interface	15
9.1.	General.....	15
9.2.	IO-Link process data	15
9.2.1.	Safe data to the IO-Link Safety Master	15
9.2.2.	Non-safe data to the IO-Link Safety Master	15
9.2.3.	Non-safe data from the IO-Link Safety Master	15
9.3.	IO-Link event and diagnostic data	16
9.3.1.	Device and diagnostic data	16
9.3.2.	Event data.....	17

10.	Setup	18
10.1.	Configuring device	18
10.2.	Parameters for the evaluation of the actuator	18
10.3.	Teaching-in actuator (only for high coding level evaluation)	19
10.4.	Function test	20
11.	Reset	20
12.	Status and error messages	21
12.1.	LED indicator	21
12.2.	Status messages	21
12.2.1.	Status messages, IO-Link communication	21
12.2.2.	Status messages, device	22
12.3.	Error messages	23
12.4.	Acknowledging error messages	24
13.	Updating firmware	24
14.	Technical data	25
14.1.	Technical data for safety switch CES-IO-.-C07	25
14.1.1.	General	25
14.1.2.	Radio frequency approvals	26
14.1.3.	Typical system times	27
14.1.4.	Dimension drawing for safety switch CES-IO-.-C07	27
14.2.	Technical data for actuators CES-A-BTN-C07-... and A-FLX-C07-...	28
14.2.1.	Dimension drawing	28
14.2.2.	Actuating ranges and installation positions	29
14.3.	Technical data for actuator CES-A-BDN-06-158210	31
14.3.1.	Dimension drawing	31
14.3.2.	Operating distances	32
14.4.	Technical data for A-C11-01-... and A-FLX-C11-05-...	33
14.4.1.	Dimension drawing	33
14.4.2.	Operating distances	33
15.	Ordering information and accessories	34
16.	Inspection and service	34
17.	Service	34
18.	Declaration of conformity	34
18.1.	Note on Directive 2014/53/EU RED (Radio Equipment Directive) and Delegated Regulation (EU) 2022/30	34

1. About this document

1.1. Scope

These operating instructions apply to all CES-I-IO-.-C07 of version V1.0.X. These operating instructions, the document *Safety information* and any available data sheet form the complete user information for your device.

They apply to:

	Product version (hardware version)	Firmware version
Safety switch CES-I-IO-.-C07	V1.0.X	V1.0.X



Important!

- ▶ Make sure to use the operating instructions valid for your product version. The version numbers can be found on the type label.
- ▶ A firmware update might have been performed on your device. Make sure that the device documentation corresponding to the update is available and is observed.
- ▶ Please contact the EUCHNER support team if you have any questions.

1.1.1. Type label

(example illustration)

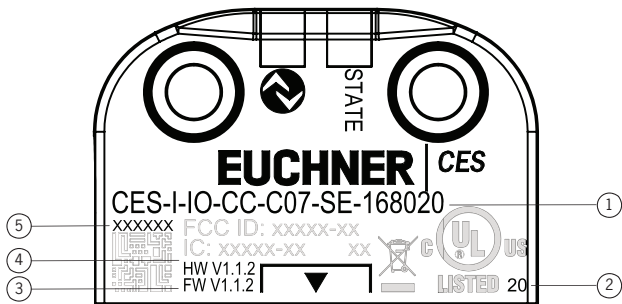

Key	
1	Item designation and order number
2	Year of manufacture
3	Firmware version on delivery
4	Product version (hardware version)
5	Serial number

1.2. Target group

Design engineers and installation planners for safety systems on machines, as well as setup and servicing staff possessing special expertise in handling safety components.







1.3. Key to symbols

Symbol/depiction	Meaning
	Evaluation of actuator code with high coding level
	Evaluation of actuator code with high coding level, actuator set
	Evaluation of actuator code with low coding level
	Printed document
	Document is available for download at www.euchner.com
 DANGER WARNING CAUTION	Safety precautions Danger of death or severe injuries Warning about possible injuries Caution slight injuries possible

 NOTICE Important!	Notice about possible device damage Important information
Tip	Useful information

1.4. Supplementary documents

The overall documentation for this device consists of the following documents:

Document title (document number)	Contents	
Safety information (2525460)	Basic safety information	
Operating instructions (MAN20001746)	(this document)	
Declaration of conformity	Declaration of conformity	
Possibly available data sheet	Item-specific information about deviations or additions	 
Information_EU-DA_110 (EC020001824)	Information on data usage in accordance with the EU Data Act	

	Important! Always read all documents to gain a complete overview of safe installation, setup and use of the device. The documents can be downloaded from www.euchner.com . For this purpose, enter the doc. no. or the order number for the device in the search box.
---	--

2. Correct use

Safety switches series CES-IO-.-C07 are operated as devices on an IO-Link Safety Master and are transponder-coded switches for the safe detection of the actuator position and for the safe transfer of the actuator number. The device complies with the requirements according to EN 60947-5-3.

In combination with a moving machine component and the machine control, this safety component prevents dangerous machine functions from occurring before the safe position is reached or, depending on the actuator type, the actuator number assigned to the machine function has been transferred.

This means:

- › Starting commands that cause a dangerous machine function must become active only when the moving machine component is in the safe position and, depending on the actuator type, the actuator number assigned to the machine function is transferred.
- › A stop command is triggered when the safe position is left.
- › The actuator number is transferred safely via the IO-Link communication and can be evaluated.
- › If used to monitor the position of a guard: closing a guard must not cause automatic starting of a dangerous machine function. A separate start command must be issued. For exceptions, refer to EN ISO 12100 or relevant C-standards.

The function and coding of the system are determined by the parameter configuration in the IO-Link Safety Master and the selection of the actuator.

Table 1: System components

Safety switch	Actuator type		
	01	04	05
	General actuator, high coding level	Actuator set, high coding level	Actuator with actuator number, low coding level
CES-I-IO-.-C07-...	CES-A-BTN-C07-156230 CES-A-BDN-06-158210 A-C11-01-175934	A-FLX-C07-04-...	A-FLX-C11-05-... A-FLX-C07-05-...

→ HC The following applies to evaluation of the actuator code with high coding level:

- › The actuator must be assigned to the safety switch by a teach-in operation so that it is detected by the system. This unambiguous assignment ensures a particularly high level of protection against tampering. The system thus possesses a high coding level.

→ LC The following applies to evaluation of the actuator code with low coding level:

- › With the low coding level evaluation, a specific code is not requested but instead it is only checked whether the actuator is of a type that can be detected by the system. There is no exact comparison of the actuator code with the taught-in code in the safety switch. The system possesses a low coding level.

Before the device is used, a risk assessment must be performed on the machine, e.g. in accordance with the following standards:

- › EN ISO 13849-1
- › EN ISO 12100
- › IEC 62061

Correct use includes observing the relevant requirements for installation and operation, particularly based on the following standards:

- › EN ISO 13849-1
- › EN ISO 14119
- › EN 60204-1

The safety switch is only allowed to be operated in conjunction with the intended EUCHNER CES actuators and the related connection components from EUCHNER. If different actuators or other connection components are used, EUCHNER provides no warranty for safe function.



Important!

- › The user is responsible for the proper integration of the device into a safe overall system. For this purpose, the overall system must be validated, e.g. in accordance with EN ISO 13849-1.
- › It is only allowed to use components that are permissible according to *Table 1: System components on page 6*.

2.1. Notes on the EU Data Act

In accordance with EU Data Act 2023/2854, it is stated that data are generated during operation of the product.

These instructions describe the type of data generated and access to the data.

You will find further information in the document *Information on data usage in accordance with the EU Data Act*.

3. Description of the safety function

Devices from this series feature the following safety functions:

Safe monitoring of the position of the actuator and safe transfer of the actuator number

- › Safety function:
 - If the moving machine component is in the safe position, the safety bit `FI_InterLock` is set.
 - If the actuator number is requested, the actuator number is transferred safely (`FI_ActuatorNumber`).
- › Safety characteristics: category, Performance Level, PFH (see chapter 14. *Technical data on page 25*).

4. Exclusion of liability and warranty

In case of failure to comply with the conditions for correct use stated above, or if the safety regulations are not followed, or if any servicing is not performed as required, liability will be excluded and the warranty void.

5. General safety precautions

Safety switches fulfill personnel protection functions. Incorrect installation or tampering can lead to fatal injuries to personnel.

Check the safe function in particular

- › after any setup work
- › after the replacement of a system component
- › after an extended period without use
- › after every fault
- › after configuration of the device in the IO-Link Safety Master
- › after every back-to-box reset
- › after every firmware update.

Independent of these checks, the safe function should be checked at suitable intervals as part of the maintenance schedule.



WARNING

Danger to life due to improper installation or due to bypassing (tampering). Safety components fulfill a personnel protection function.

- › Safety components must not be bypassed, turned away, removed or otherwise rendered ineffective. On this topic pay attention in particular to the measures for reducing the possibility of bypassing according to EN ISO 14119:2025, section 8.
- › The switching operation must be activated only by actuators designated for this purpose.
- › Prevent bypassing by means of replacement actuators (only for low coding level evaluation). For this purpose, restrict access to actuators and to keys for releases, for example.
- › The safety function is ensured only if unused actuators cannot be misused to tamper with the machine function. The user must therefore take appropriate organizational measures, such as rendering unneeded actuators in a packaging unit unusable.
- › Mounting, electrical connection and setup only by authorized personnel possessing the following knowledge:
 - specialist knowledge in handling safety components
 - knowledge about the applicable EMC regulations
 - knowledge about the applicable regulations on operational safety and accident prevention.



Important!

Prior to use, read the operating instructions and keep these in a safe place. Ensure the operating instructions are always available during mounting, setup and servicing. You can download the operating instructions from www.euchner.com.

6. Function

The safety switch monitors one or more positions of moving machine components. The corresponding data are transferred via the IO-Link communication to the IO-Link Safety Master when the actuator is moved into or out of the actuating range.

The system consists of the following components: coded actuator (transponder) and switch.

The moving machine component with the actuator is moved to the safety switch in the safe position. When the operating distances are reached, power is supplied to the actuator by the switch and data transfer begins.

If permissible coding is detected, the safety bit `FI_InterLock` is set and the corresponding data are sent to the IO-Link Safety Master. If actuator type 05 is used, the actuator number is also transferred via `FI_ActuatorNumber`. The removal of the moving machine component with the actuator is signaled via the data transfer protocol to the IO-Link Safety Master.

If there is a fault in the safety switch, a message is generated and the STATE LED indicates the fault. The occurrence of faults is detected at the latest with the next demand from a safety function to transfer the safe data (e.g. during starting).

The function and coding level of the system are determined by the parameter configuration in the IO-Link Safety Master and the selection of the actuator.

6.1. Limit-range monitoring

The device detects if the actuator drifts out of the actuating range of the switch over time. The STATE LED or the status bit `I_Weak` indicates that the actuator is in the limit range (see chapter 12. *Status and error messages on page 21*).

Readjusting the moving machine component can prevent the actuator from drifting farther out of the actuating range.

6.2. Safe position status bit

The safe position status bit (`I_InterLock`) is set if a valid actuator is detected in the actuating range and safe communication is established with the Master.

6.3. Actuator status bit

The actuator status bit (`I_Actuator`) is set if the switch detects an actuator.

6.4. Diagnostics status bit

With the aid of the diagnostics status bit (`I_Diagnose`), diagnostic and error messages are displayed (see chapter 9.3. *IO-Link event and diagnostic data on page 16 and 12. Status and error messages on page 21*).

6.5. Evaluation of the actuator

The evaluation of the actuator is configured in the IO-Link Safety Master, see chapter 10.2. *Parameters for the evaluation of the actuator on page 18.*

The following types of evaluation are available:

Evaluation of the actuator		Actuator types that can be combined		
		01	04	05
		General actuator, high coding level	Actuator set, high coding level	Actuator with actuator number, low coding level
High coding level	→ HC	●		
High coding level, set	→ HC + Set	●	●	
Low coding level	→ LC	●	●	●

The following applies to evaluation of the actuator:

→ HC

The following applies to evaluation of the actuator code with high coding level:

- › The actuator must be assigned to the safety switch by a teach-in operation so that it is detected by the system. This unambiguous assignment ensures a particularly high level of protection against tampering. The system thus possesses a high coding level.
- › The switch accepts only general actuators with a high coding level.
- › The use of sets with actuators with the same coding is excluded.
- › For further information about the teach-in operation, see chapter 10.3. *Teaching-in actuator (only for high coding level evaluation) on page 19.*

→ HC + Set

The following applies to evaluation of the actuator code with high coding level and actuators in a set:



- › The actuator must be assigned to the safety switch by a teach-in operation so that it is detected by the system. This unambiguous assignment ensures a particularly high level of protection against tampering. The system thus possesses a high coding level.
- › Actuators belonging to the same packaging unit have the same coding. Only one actuator from a packaging unit has to be taught-in. All other actuators from the same package can be used without an additional teach-in operation.
- › Both general actuators with high coding level and also sets with actuators with the same coding can be used.
- › For further information about the teach-in operation, see chapter 10.3. *Teaching-in actuator (only for high coding level evaluation) on page 19.*

→ LC

The following applies to evaluation of the actuator code with low coding level:

- › With the low coding level evaluation, a specific code is not requested but instead it is only checked whether the actuator is of a type that can be detected by the system. There is no exact comparison of the actuator code with the taught-in code in the safety switch. The system possesses a low coding level.
- › The following applies to actuator type 05:
 - The actuator number is safely transferred to the IO-Link Safety Master.
 - As this actuator type can be re-ordered, it is permitted to be used only for low coding level evaluation.

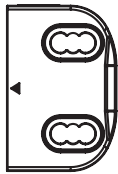
6.5.1. Actuator type 01 – general actuator, high coding level

Design	Item number
	CESA-BTN-C07-156230
	CESA-BDN-06-158210
	A-C11-01-175934

6.5.2. Actuator type 04 – actuator set, high coding level

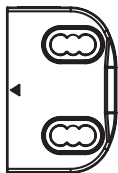
Design	Item number
	A-FLX-C07-04-V..

6.5.3. Actuator type 05 – actuator with actuator number, low coding level

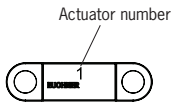
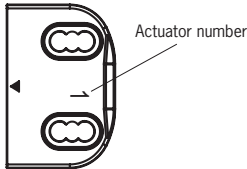
Design	Item number
	A-FLX-C11-05-NOXX-XXXXXX
	A-FLX-C07-05-NOXX-XXXXXX

The actuator number is safely transferred to the control system via the IO-Link communication and can be evaluated there.

6.6. Switching states

The detailed switching states for your switch can be found in chapter 12. *Status and error messages on page 21.* All system states, signals and display LEDs are described there.

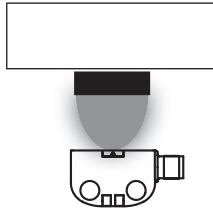
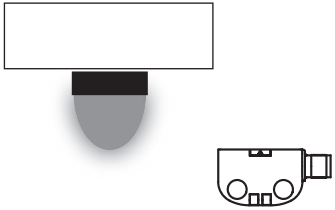
	Safe position reached (actuator in the actuating range and permissible coding detected)	Safe position left (actuator not in the actuating range)
		
Safety bit FI_InterLock	on	off
FI_ActuatorNumber 1)	is transferred	set to 0
Status bit I_InterLock	on	off
Status bit I_Actuator	on	off

1) Depending on the actuator type

7. Mounting



CAUTION

Safety switches must not be bypassed (bridged), turned away, removed or otherwise rendered ineffective.

- › Observe EN ISO 14119:2025, section 8, for information about reducing the possibilities for bypassing an interlocking device.



NOTICE

Risk of damage to equipment and malfunctions as a result of incorrect installation.

- › Safety switches and actuators must not be used as an end stop.
- › Observe EN ISO 14119:2025, sections 6.2 and 6.3, for information about mounting the safety switch and the actuator.
- › From the assured release distance S_{ar} , the safe data $FI_InterLock = 0$ and $FI_Actuator-Number = 0$ are sent. The system is in the safe state.
- › When mounting several safety switches, observe the stipulated minimum distance to avoid mutual interference.

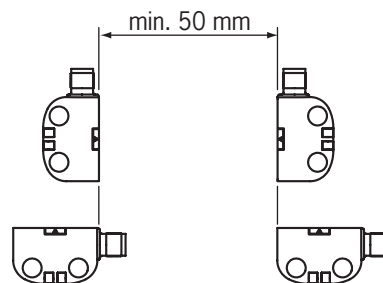

- › Recessed installation of the actuator changes the operating distances as a function of the surrounding material.
- › The actuators A-C11-01-... and A-FLX-C11-05-... can be installed recessed up to a groove depth of max. 3 mm.
- › Observe permissible installation positions (see Fig. 1 and Fig. 2).

Note the following points:

- › Actuator and safety switch must be easily accessible for inspection and replacement.
- › Actuator and safety switch must be fitted so that
 - a minimum distance is maintained with a side approach direction to avoid entering the area of possible side lobes, see chapter 14. *Technical data*, section *Typical actuating range* for the related actuator.
 - in a machine position that is not safe up to the distance S_{ar} (assured release distance), a hazard is excluded.
 - the actuator is positively mounted on the moving machine component, e.g. by using the safety screws included.
 - the safety screws cannot be removed or tampered with using simple means.
- › Pay attention to the maximum tightening torque for the safety switch and actuator mountings of 0.8 Nm.
- › Seal the mounting holes on the switch after mounting using the caps provided to prevent the accumulation of dirt.
- › In order to prevent damage, the connecting cable must be laid with protection in areas in which high-pressure cleaners are used.

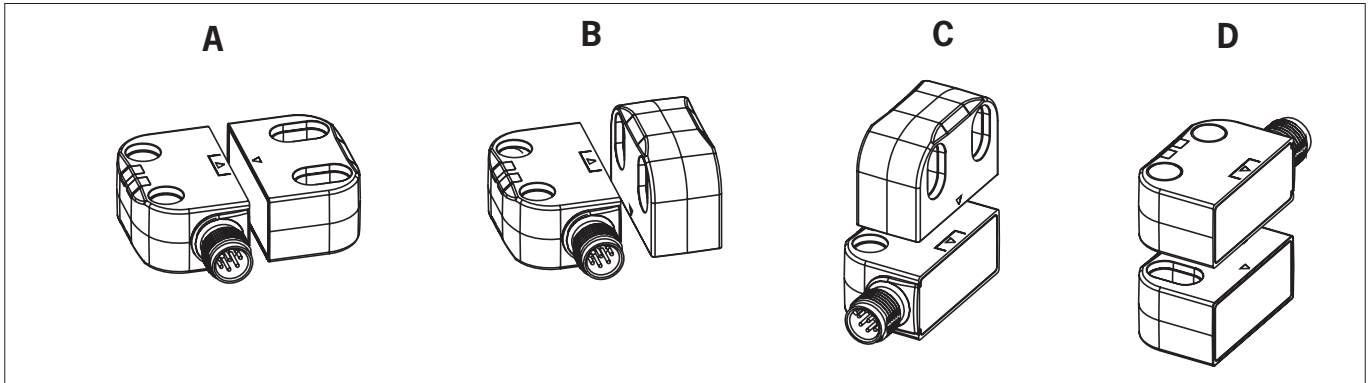

Fig. 1: Permissible installation positions for actuators CES-A-BTN-C07-... and A-FLX-C07-...: observe direction of arrow on the device.

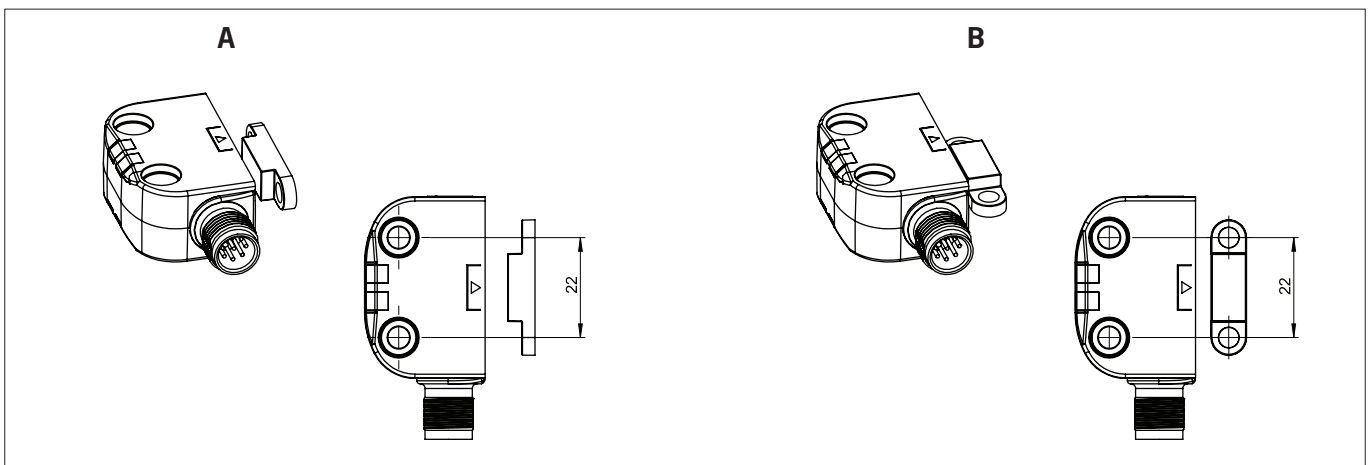

Fig. 2: Permissible installation positions for actuators A-C11-01-... and A-FLX-C11-05-...

8. Electrical connection



CAUTION

Risk of damage to equipment or malfunctions as a result of incorrect connection.

- › All electrical connections must either be isolated from the mains supply by a safety transformer according to IEC 61558-2-6 with limited output voltage in the event of a fault, or by other equivalent insulation measures (PELV).
- › Power devices which are a powerful source of interference must be installed in a separate location away from the input and output circuits for signal processing. The cable routing for safety circuits should be as far away as possible from the cables of the power circuits.
- › To avoid EMC interference, the physical environmental and operating conditions at the installation site of the device must comply with the requirements according to the standard EN 60204-1 (EMC).
- › Pay attention to any interference fields from devices such as frequency converters or induction heating systems. Observe the EMC instructions in the manuals from the respective manufacturer.



Important!

If the device does not appear to function when the operating voltage is applied (e.g. the STATE LED does not flash), the safety switch must be returned unopened to EUCHNER.

8.1. Connector assignment, safety switch CES-I-IO-.-C07 with plug connector M12, 5-pin

Plug connector (view of connection side)	Pin	Designation	Function
	1	L+	Power supply from IO-Link Safety Master (+)
	2	-	n.c.
	3	L-	Power supply from IO-Link Safety Master (-)
	4	C / Q	Communication connection, IO-Link
	5	-	n.c.

8.2. Notes about UL



Important!

- › This device is intended to be used with a Class 2 power source in accordance with UL1310. As an alternative an LV/C (Limited Voltage/Current) power source with the following properties can be used:
 - This device shall be used with a suitable isolating source in conjunction with a fuse in accordance with UL248. The fuse shall be rated max. 3.3 A and be installed in the max. 30 V DC power supply to the device in order to limit the available current to comply with the UL requirements. Please note possibly lower connection ratings for your device (refer to the technical data).
- › For use and application as per the requirements of UL ¹⁾, a connecting cable listed under the UL category code CYJV2 or CYJV must be used.

1) Note on the scope of the UL approval: the devices have been tested as per the requirements of UL508 and CSA/ C22.2 no. 14 (protection against electric shock and fire). Only for applications as per NFPA 79 (Industrial Machinery).

9. IO-Link interface

9.1. General

The switch has an IO-Link interface for the communication with an IO-Link Safety Master.

The system commands and parameters as well as the process data are described in the IO Device Description IODD. The IODD is available at www.euchner.com in the *Service/Downloads/Software* area.

9.2. IO-Link process data

9.2.1. Safe data to the IO-Link Safety Master

FS-PDin:

- › FI_InterLock: actuator position monitoring, 1 bit
- › FI_ActuatorNumber: actuator number, INT16

FS-PDin	Bit 7	Bit 6	Bit 5	Bit 4	Bit 3	Bit 2	Bit 1	Bit 0
Byte 0	-	-	-	-	-	-	-	FI_InterLock
Byte 1	FI_ActuatorNumber (INT16)							
Byte 2								

9.2.2. Non-safe data to the IO-Link Safety Master

PDin:

- › I_AckReq: acknowledgment request
- › I_Actuator: actuator
- › I_Weak: limit range
- › I_Diagnose: diagnostics
- › I_InterLock: safe position

For further information, see chapter 6. *Function on page 9.*

PDin	Bit 7	Bit 6	Bit 5	Bit 4	Bit 3	Bit 2	Bit 1	Bit 0
Byte 0	I_AckReq	I_Actuator	I_Weak	I_Diagnose	-	-	-	I_InterLock

9.2.3. Non-safe data from the IO-Link Safety Master

PDout:

- › O_Ack: acknowledgment bit

PDout	Bit 7	Bit 6	Bit 5	Bit 4	Bit 3	Bit 2	Bit 1	Bit 0
Byte 0	O_Ack	-	-	-	-	-	-	-

9.3. IO-Link event and diagnostic data

9.3.1. Device and diagnostic data

The event log is sorted chronologically. Subindex 1 contains the latest event.

Index		Information	Size/format	Value
Hex	Dec			
0x0000	0	VendorID	uint32	Subindex 8 Subindex 9
		DeviceID		Subindex 10 Subindex 11 Subindex 12
0x0010	16	VendorName	String max. 64 octets	Euchner GmbH + Co. KG
0x0011	17	VendorText	String max. 64 octets	www.euchner.com
0x0012	18	ProductName	String max. 64 octets	
0x0013	19	ProductID	String max. 64 octets	
0x0014	20	ProductText	String max. 64 octets	
0x0015	21	SerialNumber	String max. 64 octets	
0x0016	22	HardwareRevision	String max. 64 octets	
0x0017	23	FirmwareRevision	String max. 64 octets	
0x0018	24	ApplicationSpecificTag	String max. 64 octets	
0x0019	25	FunctionTag	String max. 32 octets	
0x001A	26	LocationTag	String max. 32 octets	
0x0024	36	Device status	uint8	0 = Device is functioning correctly 1 = Servicing required 2 = Outside the specification 3 = Function test 4 = Fault
0x0025	37	Detailed device status	Array [4] of 3-octet strings	See chapter 9.3.2. <i>Event data on page 17</i>
0x0040	64	Temperature in °C	int8	
0x0041	65	Supply voltage in mV	uint16	
0x0042	66	Number of switching cycles	uint32	
0x0043	67	Current actuator data	uint16	Subindex 1: actuator code
			uint16	Subindex 2: actuator number
0x0044	68	Taught-in actuator code	uint16	
0x0045	69	Disabled actuator code	uint16	
0x0046	70	RFID signal strength in %	uint8	0 - 100 %
0x004B	75	Actuator evaluation mode	uint8	High coding level High coding level, set Low coding level
0x0100	256	Bootloader revision		
0x0101	257	Event log	Array [68] of uint16	See chapter 9.3.2. <i>Event data on page 17</i>
0x0102	258	Internal log part 1	215 bytes	Internal format for evaluation by EUCHNER
0x0103	259	Internal log part 2	215 bytes	
0x0104	260	Internal log part 3	215 bytes	
0x0105	261	Internal log part 4	215 bytes	
0x0106	262	Internal log part 5	215 bytes	

9.3.2. Event data

The event log is sorted chronologically. Subindex 1 contains the latest event.

You will find detailed information about troubleshooting in chapter 12.3. *Error messages on page 23.*

Event code		Event	Type / reset	Event type
Hex	Dec			
0x0000	0	No malfunction	-	-
0x1000	4096	General malfunction - Unknown error	Latching	Error
0x1802	6146	Teach-in in progress	Is reset automatically	Warning
0x1804	6148	No actuator taught in – Teach-in required	Is reset automatically	Warning
0x181F	6175	Actuator removed during teach-in operation	Latching	Error
0x1825	6181	Disabled actuator detected during teach-in operation	Latching	Error
0x1842	6210	Invalid actuator detected during teach-in operation	Latching	Error
0x1844	6212	Invalid actuator detected	Is reset automatically	Warning
0x1845	6213	Defective actuator detected during teach-in operation	Latching	Error
0x1846	6214	Defective actuator detected	Is reset automatically	Warning
0x1847	6215	Disabled actuator detected	Is reset automatically	Warning
0x1848	6216	Actuator not taught-in detected	Is reset automatically	Warning
0x1860	6240	Primary supply voltage fault – Overrun	Latching	Error
0x1861	6241	Primary supply voltage fault – Underrun	Latching	Error
0x1863	6243	Temperature fault – Underrun	Latching	Error
0x18B0	6320	IO-Link Safety – Incorrect Protocol Version		Error
0x18B1	6321	IO-Link Safety – Incorrect Protocol Mode		Error
0x18B2	6322	IO-Link Safety – Incorrect Protocol Datalength		Error
0x18F1	6385	Weak signal – Limit range warning	Is reset automatically	Warning
0x18F7	6391	Firmware update failed		Error
0x18FC	6396	Firmware update initiated	-	Log entry
0x18FD	6397	Back-to-box Reset or Application Reset performed	-	Log entry
0x18FE	6398	Teach-in successful - Waiting for Acknowledgment	Latching	Error
0x4000	16384	Temperature fault – Overload	Latching	Error
0x4210	16912	Device temperature overrun – Clear source of heat	Is reset automatically	Warning
0x4220	16928	Device temperature underrun – Insulate Device	Is reset automatically	Warning
0x5110	20752	Primary supply voltage overrun – Check tolerance	Is reset automatically	Warning
0x5111	20753	Primary supply voltage underrun – Check tolerance	Is reset automatically	Warning
0xB000	45056	Transmission error (CRC signature)		Message
0xB001	45057	Transmission error (Counter)		Message
0xB002	45058	Transmission error (Timeout)		Error
0xB003	45059	Unexpected authentication code		Error
0xB004	45060	Unexpected authentication Port		Error
0xB005	45061	Incorrect FSP_AuthentCRC		Error
0xB006	45062	Incorrect FSP_ProtParCRC		Error
0xB007	45063	Incorrect FSP_TechParCRC		Error
0xB008	45064	Incorrect FSP_IO_StructCRC		Error
0xB009	45065	Watchdog time out of specification (e.g. "0")		Error
0xB00A	45066	No FSP_VerifyRecord received (triggered after transition to OPERATE)		

10. Setup

10.1. Configuring device

The device is configured in the higher-level control system for the IO-Link Safety Master.



WARNING

Danger to life due to incorrect configuration

- › During initial configuration or reconfiguration, ensure that a risk assessment has been performed for the selected function.

If you want to reconfigure a device already configured, it is recommended to perform a reset first (see chapter 11. Reset on page 20).

1. Download the IODD for the device from www.euchner.com in the *Service/Downloads/Software/Device description files* area and load into the interpreter for the IO-Link Safety Master.
 2. Connect the device to the IO-Link Safety Master.
 3. Configure the device in the configuration software for the IO-Link Safety Master to suit the configuration and system environment.
 4. Configure the actuator evaluation (see chapter 10.2. Parameters for the evaluation of the actuator on page 18).
 5. Transfer configuration to the device.
 6. Briefly disconnect the supply of power to the device.
- ➔ The device is restarted and applies the new configuration.

10.2. Parameters for the evaluation of the actuator

The evaluation of the actuator in the safety switch is configured via the IO-Link communication using the *FS Technology Parameter "Actuator Evaluation Mode"*.

Depending on the evaluation required, it is necessary to set the following parameters:



Evaluation of the actuator (column 1)	Actuator evaluation mode	
	FS Technology Parameter (column 2)	Protocol.FSP_TechParCRC (column 3)
High coding level → HC	HighCoded (TechPar:4104977171)	4104977171
High coding level, set → HC + Set	HighCoded Set (TechPar:502598965)	502598965
Low coding level → LC	LowCoded (TechPar:3914987046)	3914987046

1. Specify type of evaluation (column 1).
 2. In *FS Technology Parameter*, select the corresponding *actuator evaluation mode* (column 2).
 3. In *FS Protocol Parameter*, enter the corresponding value (column 3) for *Protocol.FSP_TechParCRC*.
 4. Set the remaining parameters as per the configuration and system environment.
- ➔ The value in *Protocol.FSP_ProtParCRC* can be calculated using the Master tool.

10.3. Teaching-in actuator (only for high coding level evaluation)

For high coding level evaluation, the actuator must be allocated to the safety switch using a teach-in operation before the system forms a functional unit.

During a teach-in operation, the system is in the safe state, i.e. the safety bits `FI_InterLock` and `FI_ActuatorNumber` are not set.

	<p>DANGER</p> <p>Danger to life due to tampering</p> <ul style="list-style-type: none"> › Unused actuators from a packaging unit (actuator type 04) must be rendered unusable or protected against unauthorized access to prevent bypassing of the safety function.
	<p>Tip!</p> <p>It is recommended to perform the teach-in operation prior to mounting. Mark switches and actuators that belong together in order to prevent confusion.</p>
	<p>Important!</p> <ul style="list-style-type: none"> › The teach-in operation may be performed only if the device functions flawlessly. The STATE LED flashes green slowly. › Actuators belonging to the same packaging unit (actuator type 04) have the same coding. Only one actuator from a packaging unit has to be taught-in. All other actuators from the same package can be used without an additional teach-in operation. › The safety switch disables the code of the preceding device if teach-in is carried out for a new actuator. Teach-in is not possible again immediately for this device if a new teach-in operation is carried out. The disabled code is enabled again in the safety switch only after a third code has been taught-in. › The safety switch can be operated only with the last actuator taught-in. › The number of teach-in operations is unlimited. › If the switch detects the actuator that was most recently taught-in when in teach-in standby, this state is ended immediately and the switch changes to normal operation. › If the actuator to be taught-in is in the actuating range for less than 30 s, it will not be activated and the most recently taught-in actuator will remain saved.

Prerequisite:

› The device is configured for high coding level evaluation, see chapter 10.2. *Parameters for the evaluation of the actuator on page 18.*

1. Make sure there is no actuator in the actuating range.
2. Apply operating voltage.
 - ➔ The STATE LED flashes white quickly (5 Hz). The device carries out a self-test.
 - ➔ The device is in teach-in standby for up to 3 min. On switches that have not been taught in, teach-in standby is unlimited. The STATE LED illuminates white.
3. Move to the device an actuator that has not been taught-in.
 - ➔ The teach-in operation begins. The STATE LED flashes alternately white/violet slowly.
 - ➔ The teach-in operation ends after approx. 30 s. The STATE LED flashes alternately green/blue quickly (approx. 3 Hz).
4. Switch off operating voltage for at least 3 s.
 - ➔ The code of the new actuator taught-in is activated in the safety switch. The actuator is valid.
5. Switch on operating voltage.
 - ➔ The device operates normally.

10.4. Function test



WARNING

- Danger of fatal injury as a result of faults in installation and the functional check.
- › Before carrying out the functional check, make sure that there are no persons in the danger area.
 - › Observe the valid accident prevention regulations.

After installation and after any fault, the safety function must be fully checked. Proceed as follows:

Prerequisite:

- › The moving machine components are not in the safe position.

1. Switch on operating voltage.
 - ➔ The machine must not start automatically.
 - ➔ The safety switch carries out a self-test.
2. Move all moving machine components to the safe position.
 - ➔ The related machine function must be executed.
 - ➔ The STATE LED illuminates green.
3. If necessary, enable operation in the control system.
4. Move the moving machine components out of the safe position.
 - ➔ The related machine function must be interrupted and it must not be possible to start the function as long as the moving machine component is not in the safe position.
 - ➔ The STATE LED flashes green slowly.

Repeat steps 2 - 4 separately for each safe position and, for actuator type 05, for each actuator number used.

11. Reset

The following types of reset via the IO-Link communication are possible to reset the device:

	IO-Link system command		Description
	Hex	Dec	
Application reset	0x81	129	<ul style="list-style-type: none"> › An application reset is possible only during setup (commissioning mode*). › The parameter <i>FS Technology Parameter</i> is reset to the default value. › Taught-in actuators remain valid.
Back-to-box reset	0x83	131	<ul style="list-style-type: none"> › A back-to-box reset is possible only during setup (commissioning mode*). › The configuration is deleted and the device's factory settings are restored. › Taught-in actuators are deleted. › After the back-to-box reset, a device restart is required.

* You will find further information in the description of your Master tool.

12. Status and error messages

12.1. LED indicator

LED	Color
IO-Link	green
STATE	RGB

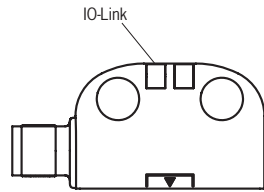

Important!

If you do not find the displayed device status in the following tables, this indicates an internal device fault. Contact the EUCHNER support team.













Key to symbols			LED not illuminated
			LED illuminated
			LED flashes quickly (5 Hz)
			LED flashes slowly (1 Hz)
			LEDs flash alternately

12.2. Status messages

12.2.1. Status messages, IO-Link communication











LED indicator	Status
IO-Link (green)	
	No communication with the IO-Link Safety Master
	Non-safe communication with the IO-Link Safety Master
	Safe communication with the IO-Link Safety Master

12.2.2. Status messages, device

Operating mode	Status code via IO-Link		LED indicator STATE (RGB)	FI_Inter-Lock and FI_ActuatorNumber 1)	Status bit Safe position I_Inter-Lock	Status bit Actuator I_Actuator	Status
	Hex	Dec					
Self-test			 white quickly	off	off	off	Self-test after operating voltage is switched on.
Normal operation	0x0000		 green slowly	off	off	off	The device is ready for operation.
			 green	on	on	on	The safe position has been reached.
	0x18F1	6385	 green/orange quickly	on	on	on	The safe position has been reached. The actuator is in the limit range. The moving machine component must be readjusted.
Teach-in operation			 white	off	off	off	Device is in teach-in standby for up to 3 min (see chapter 10.3. Teaching-in actuator (only for high coding level evaluation) on page 19).
	0x1804	6148	 white slowly			off	Device is in unlimited teach-in standby (see chapter 10.3. Teaching-in actuator (only for high coding level evaluation) on page 19).
	0x1802	6146	 white/violet slowly			on	Teach-in operation.
	0x18FE	6398	 green/blue quickly			on	Positive acknowledgment after completion of teach-in operation.
Reset	0x18FD	6397	 white/blue quickly	off	off	off	Back-to-box reset.
Firmware update	0x18FC	6396	 white/violet quickly	off	off	off	Updating the firmware.
			 green/purple quickly				The firmware update was successful.
			 red/purple quickly				Error during firmware update.
Error	depending on the error		depending on the error	off	off	depending on the error	Error message (see chapter 12.3. Error messages on page 23).

1) Depending on the actuator type

12.3. Error messages

Error code via IO-Link		LED indicator	Error	Troubleshooting	Ac-knowledging errors	
Hex	Dec	STATE RGB			Acknowledge via IO-Link	Disconnect power supply
Teach-in errors						
0x181F	6175	 white/red slowly	Actuator removed from the actuating range prior to the end of the teach-in operation.	Check whether the actuator is outside the actuating range or in the limit range.		●
0x1825	6181	 blue quickly	Disabled actuator detected during the teach-in operation: The actuator was taught-in during the penultimate teach-in operation and is disabled for the current teach-in operation.	Repeat the teach-in operation with a new actuator (see chapter 10.3. <i>Teaching-in actuator (only for high coding level evaluation)</i> on page 19).		●
0x1842	6210	 blue slowly	Invalid actuator detected: The actuator is not intended for the current device configuration.	<ul style="list-style-type: none"> Perform the teach-in operation with an actuator intended for the current device configuration. If the device is to be reconfigured, observe chapter 10.2. <i>Parameters for the evaluation of the actuator</i> on page 18. 		●
0x1845	6213	 blue	Faulty or incompatible actuator detected: The actuator's data structure cannot be read. The actuator is faulty or is not suitable for the device.	Repeat teach-in operation with new actuator.		●
Transponder/read errors						
0x1844	6212	 blue slowly	Invalid actuator detected during operation: The actuator is not intended for the current device configuration.	Use a valid actuator.		
0x1846	6214	 blue	Faulty or incompatible actuator detected during operation: The actuator's data structure cannot be read. The actuator is faulty or is not suitable for the device.			
0x1847	6215	 blue quickly	Disabled actuator detected during operation: The actuator is not the currently valid actuator.			
0x1848	6216	 white/blue slowly	Actuator not taught-in detected during operation.		<ul style="list-style-type: none"> Use the currently valid actuator. Teach-in actuator. 	
Environment errors						
0x1860	6240	 orange/red slowly	Supply voltage too high.	<ul style="list-style-type: none"> Observe the specified supply voltage (see chapter 14. <i>Technical data</i> on page 25). Observe the specified temperature range (see chapter 14. <i>Technical data</i> on page 25). Check system configuration: cable length, number of devices in the switch chain. 	●	●
0x1861	6241		Supply voltage too low.		●	●
0x4000	16384		Device temperature too high.		●	●
0x1863	6243		Device temperature too low.		●	●
Internal fault						
0x1000	4096	 red	Internal device fault	Restart the device. On repeated occurrence, contact the EUCHNER support team.		●
-		○				

12.4. Acknowledging error messages

Depending on the type of error, the switch sends a request to acknowledge the error message via the status bit `I_AckReq`. After the rectification of the cause of the fault, the error message can be acknowledged as follows:

- › Briefly disconnecting the power supply
- › Sending the acknowledgment bit `O_ACK` via the IO-Link communication (see chapter 9.2. *IO-Link process data on page 15*)



Important!

Contact the EUCHNER support team if the error message is not reset after acknowledgment.

13. Updating firmware

The device's firmware can be updated via the IO-Link communication.



WARNING

Loss of the safety function

A firmware update can change or expand functions.

Observe the following points to ensure the safety function:

- › Carefully observe the release notes for the respective firmware version prior to the update process. Ensure that the changes triggered by the firmware update continue to comply with the requirements of the overall system.
- › Perform a risk assessment on the overall system before the update if necessary, because the update could change functions or processes in the EUCHNER device.
- › Before the update process is started, the installation and the system environment must be in a safe state.
- › The update process must not be performed while the installation is in operation.
- › After completion of a firmware update, the device must be subjected to a functional check.
- › Ensure that the device documentation corresponding to the update is available and is observed after the device update.



Important!

EUCHNER update files are comprehensively checked. However, it cannot be ruled out that the update files may be incomplete or corrupt, e.g. due to an erroneous data transfer.

Liability for damage due to erroneous data transfer is excluded.

14. Technical data



NOTICE

If a data sheet is available for the product, the information on the data sheet applies.

14.1. Technical data for safety switch CES-I-IO-.-C07

14.1.1. General

Parameter	Value			Unit
	min.	typ.	max.	
General				
Housing material	Plastic PBT-PC-GF30			
Ambient temperature at UB = 24 V DC	- 25	-	+ 70	°C
Operating altitude	-	-	4,000	m
Degree of protection	IP65/IP67/IP69/IP69K			
Safety class	III			
Degree of contamination	3			
Installation position	Any			
Mounting type	Surface mounting on metal			
Connection	Plug connector M12, 5-pin, class A			
Power supply	18		30	V DC
Current consumption	-	-	30	mA
External fuse (operating voltage)	0.25	-	8	A
Reverse polarity protection	Yes			
Rated insulation voltage Ui	75			V
Rated impulse withstand voltage Uimp	1.5			kV
Conditional short-circuit current	100			A
Shock and vibration resistance	Acc. to EN 60947-5-3			
Switching frequency	-	-	1	Hz
Turn-on time	75			ms
Repeat accuracy R	-	-	10	%
EMC protection requirements	Acc. to EN 60947-5-3			
Ready delay	-	1	-	s
IO-Link interface				
IO-Link version	1.1			
IO-Link safety version	1.1.4			
SIO mode	No			
Data rate	COM2 (38.4 kbps)			
Process data length, input	10			byte
Process data length, output	7			byte
Minimum cycle time	10			ms
(WCDT) Worst case delay time			75	ms
(OFDT) One fault delay time			75	ms
Characteristics acc. to EN ISO 13849-1 and EN 62061				
	Actuator position monitoring		Safe transfer of the actuator number	
Category	4		4	
Performance Level	PL e		PL e	
PFH	1.42 x 10 ⁻⁹		1.42 x 10 ⁻⁹	
Mission time	20		20	
Maximum SIL	3		3	

14.1.2. Radio frequency approvals

FCC ID: 2AJ58-24

IC: 22052-24

FCC/IC requirements

This device complies with part 15 of the FCC Rules and with Industry Canada's licence-exempt RSSs. Operation is subject to the following two conditions:

- 1) This device may not cause harmful interference, and
- 2) this device must accept any interference received, including interference that may cause undesired operation.

Changes or modifications not expressly approved by the party responsible for compliance could void the user's authority to operate the equipment.

Note: This equipment has been tested and found to comply with the limits for a Class A digital device, pursuant to part 15 of the FCC Rules. These limits are designed to provide reasonable protection against harmful interference when the equipment is operated in a commercial environment. This equipment generates, uses, and can radiate radio frequency energy and, if not installed and used in accordance with the instruction manual, may cause harmful interference to radio communications. Operation of this equipment in a residential area is likely to cause harmful interference in which case the user will be required to correct the interference at his own expense.

RF Exposure Information (FCC & IC)

This device meets FCC and Industry Canada (IC) RF exposure guidelines. A minimum separation distance of 50 cm must be maintained between the user's body (including the hand) and the handset, including the antenna, to comply with safety requirements.

Third-party accessories (e.g., belt-clips, holsters) containing metallic components should be avoided as they may not comply with RF exposure guidelines.

Le présent appareil est conforme aux CNR d'Industrie Canada applicables aux appareils radio exempts de licence. L'exploitation est autorisée aux deux conditions suivantes :

- (1) l'appareil ne doit pas produire de brouillage, et
- (2) l'utilisateur de l'appareil doit accepter tout brouillage radioélectrique subi, même si le brouillage est susceptible d'en compromettre le fonctionnement.

Informations sur l'exposition aux radiofréquences (FCC et IC)

Cet appareil est conforme aux directives d'exposition aux radiofréquences de la FCC et d'Industrie Canada (IC). Une distance minimale de 50 cm doit être maintenue entre le corps de l'utilisateur (y compris la main) et le combiné, antenne comprise, afin de respecter les exigences de sécurité.

Les accessoires tiers (clips de ceinture, étuis de protection) contenant des pièces métalliques doivent être évités, car ils pourraient contrevenir aux directives sur l'exposition aux radiofréquences.

Supplier's Declaration of Conformity

47 CFR § 2.1077 Compliance Information

Unique Identifier:

CES-IO series

Responsible Party – U.S. Contact Information

EUCHNER USA Inc.

1665 N. Penny Lane
Schaumburg
Illinois 60173

+1 315 701-0315
info(at)euchner-usa.com
<http://www.euchner-usa.com>

14.1.3. Typical system times

Refer to the technical data for the exact values.

Ready delay: After switch-on, the device carries out a self-test. The system is ready for operation only after this time.

Turn-on time: The max. reaction time t_{on} is the time from the moment when the actuator is in the actuating range to the moment when the safety bits `FI_Interlock` and `FI_ActuatorNumber` are set.

Risk time according to EN 60947-5-3: The risk time (worst case delay time / one fault delay time) is the maximum time until the safe state is signaled by the Master when the actuator is removed from the actuating range.

14.1.4. Dimension drawing for safety switch CES-I-IO-.C07

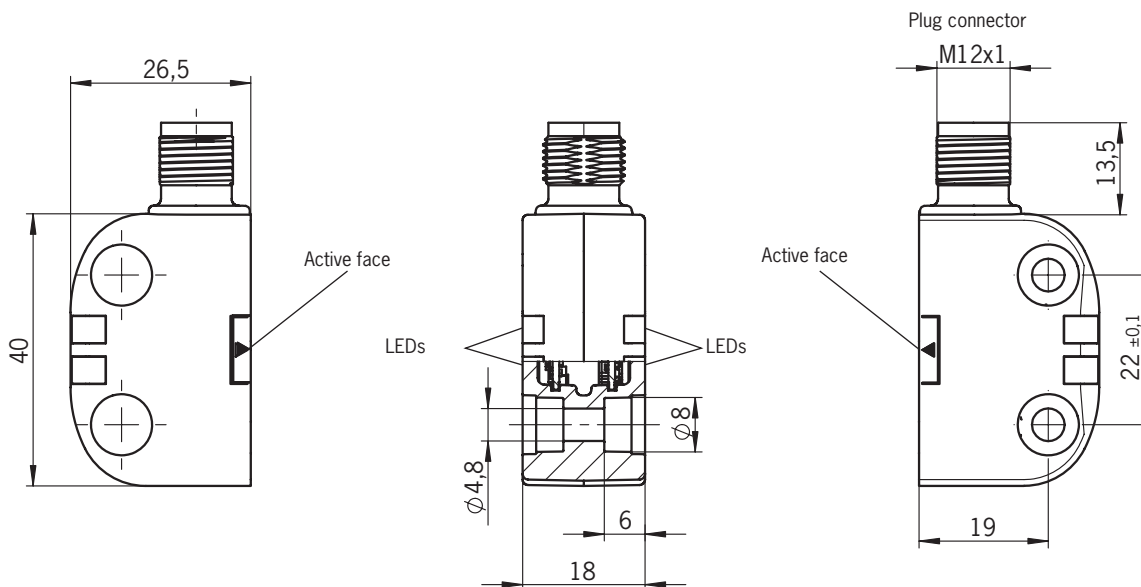

NOTICE

› Covers included.

14.2. Technical data for actuators CES-A-BTN-C07-... and A-FLX-C07-...

Parameter	Value			Unit
	min.	typ.	max.	
Housing material	Plastic PBT-PC-GF30			
Ambient temperature	- 40	-	+ 70	°C
Degree of protection	IP65/IP67/IP69/IP69K			
Installation position	Active face opposite switch			
Power supply	Inductive via switch			

14.2.1. Dimension drawing

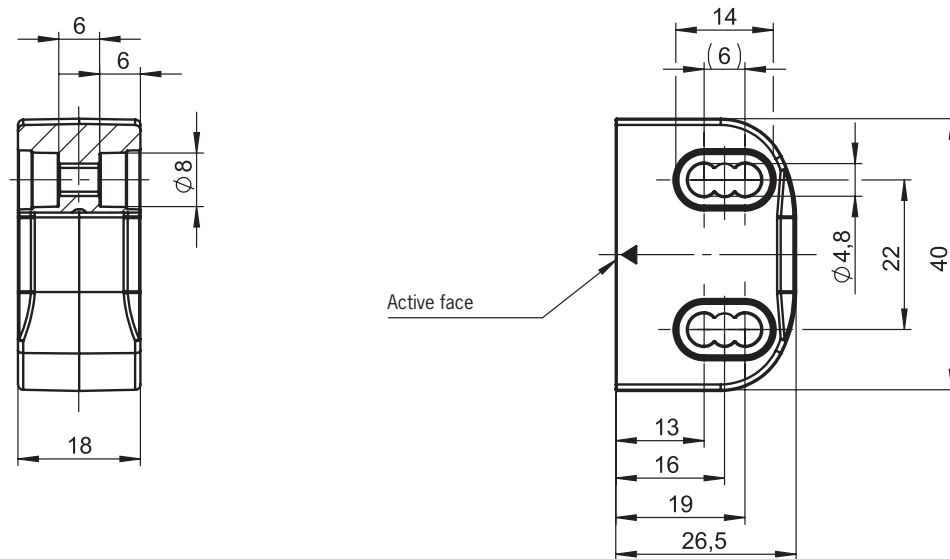

NOTICE

› 2 safety screws M4x20 included.

14.2.2. Actuating ranges and installation positions

(only in conjunction with actuators CES-A-BTN-C07-... and A-FLX-C07-...)

Typical operating distance in installation position A

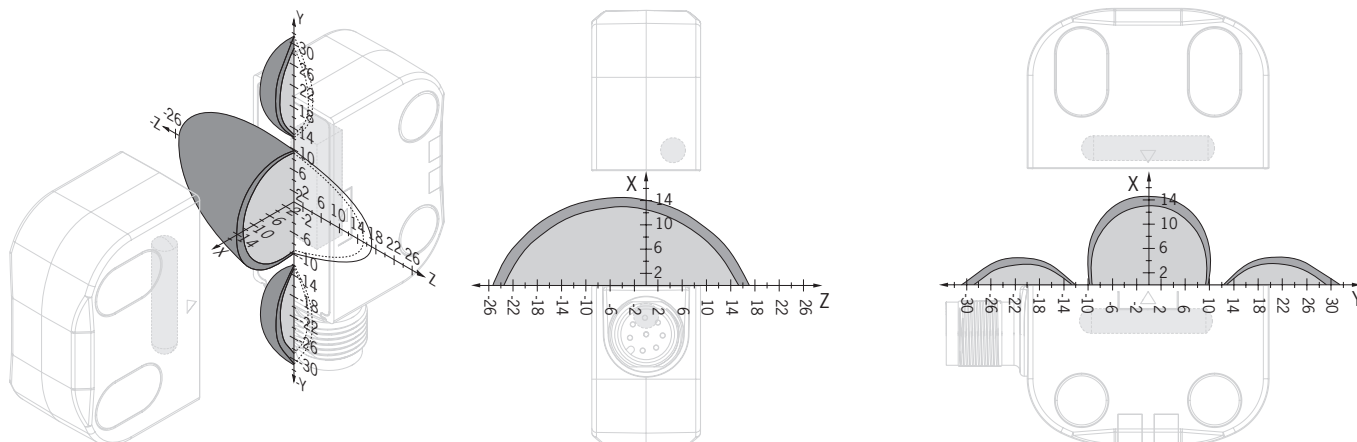

Operating distances for approach from x direction without center offset (z, y = 0)*

Parameter	Value			Unit
	min.	typ.	max.	
Operating distances	-	13	-	mm
Assured operating distance sa _o	10	-	-	
Switching hysteresis	1	2	-	
Assured release distance sar	-	-	20	

* The data apply to mounting the actuator on a non-metallic substrate. Depending on the substrate material, the actuating range may change.

Typical operating distance in installation position B

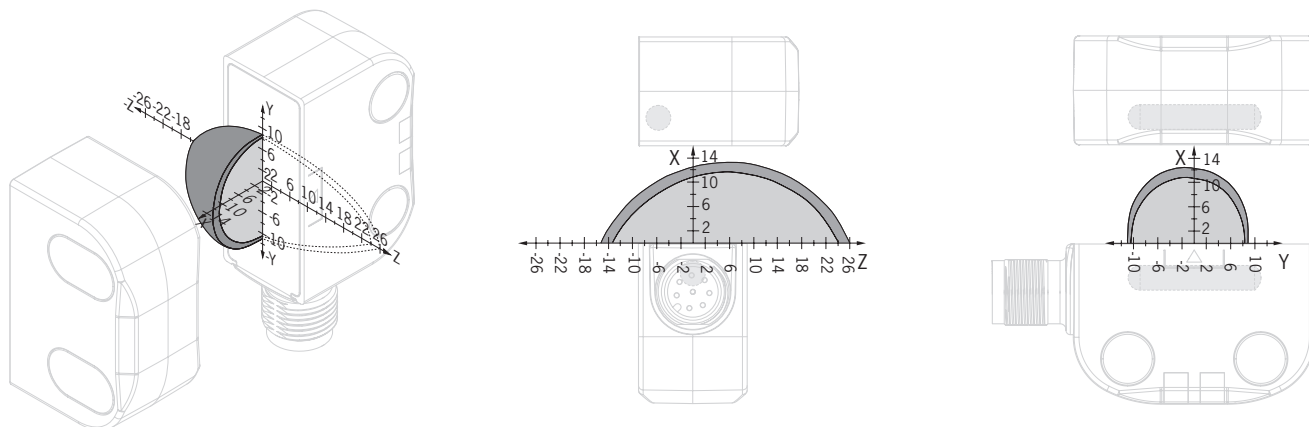

Operating distances for approach from x direction without center offset (z, y = 0)*

Parameter	Value			Unit
	min.	typ.	max.	
Operating distances	-	13	-	mm
Assured operating distance sa _o	9	-	-	
Switching hysteresis	1	2	-	
Assured release distance sar	-	-	20	

* The data apply to mounting the actuator on a non-metallic substrate. Depending on the substrate material, the actuating range may change.

Typical operating distance in installation position C

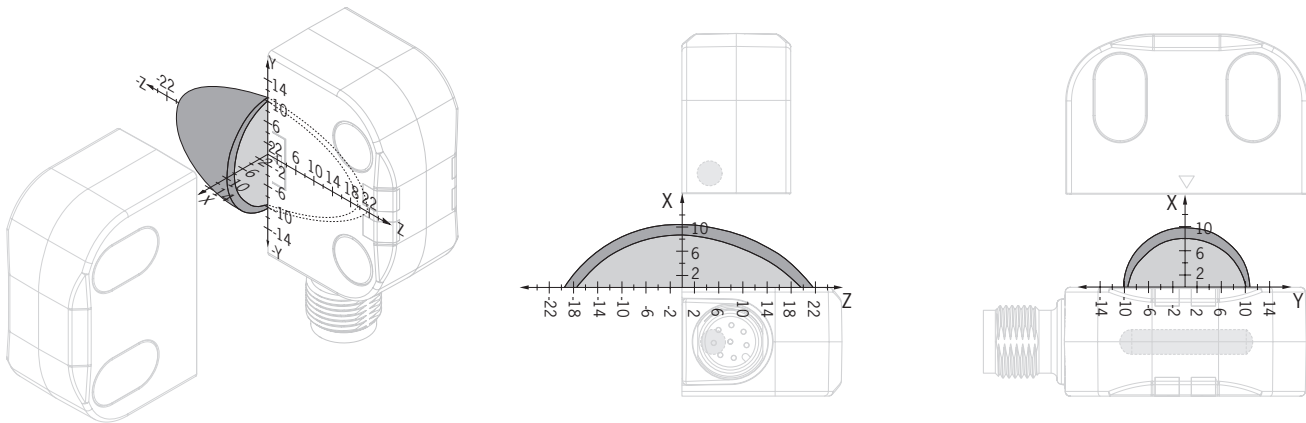

Operating distances for approach from x direction without center offset (z, y = 0)*

Parameter	Value			Unit
	min.	typ.	max.	
Operating distances	-	7	-	mm
Assured operating distance sa _o	3	-	-	
Switching hysteresis	1	2	-	
Assured release distance sar	-	-	17	

* The data apply to mounting the actuator on a non-metallic substrate. Depending on the substrate material, the actuating range may change.

Typical operating distance in installation position D

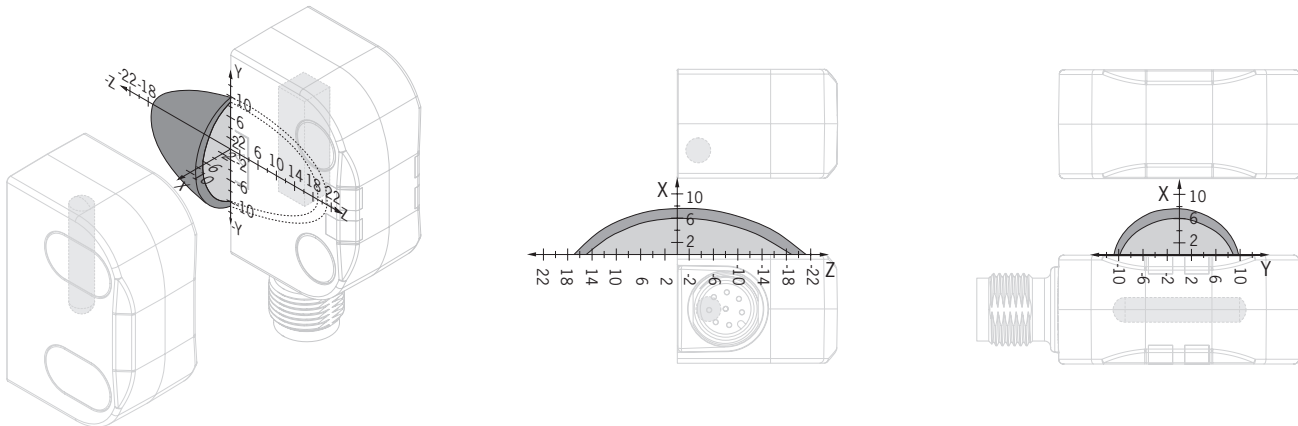

Operating distances for approach from x direction without center offset (z, y = 0)*

Parameter	Value			Unit
	min.	typ.	max.	
Operating distances	-	7	-	mm
Assured operating distance sa _o	2	-	-	
Switching hysteresis	1	2	-	
Assured release distance sar	-	-	17	

* The data apply to mounting the actuator on a non-metallic substrate. Depending on the substrate material, the actuating range may change.

14.3. Technical data for actuator CES-A-BDN-06-158210

Parameter	Value			Unit
	min.	typ.	max.	
Housing material	Macromelt PA-based plastic			
Ambient temperature	- 40	-	+ 70	°C
Degree of protection	IP65/IP67/IP69/IP69K 1)			
Installation position	Active face opposite switch			
Power supply	Inductive via switch			

1) With flush installation

14.3.1. Dimension drawing

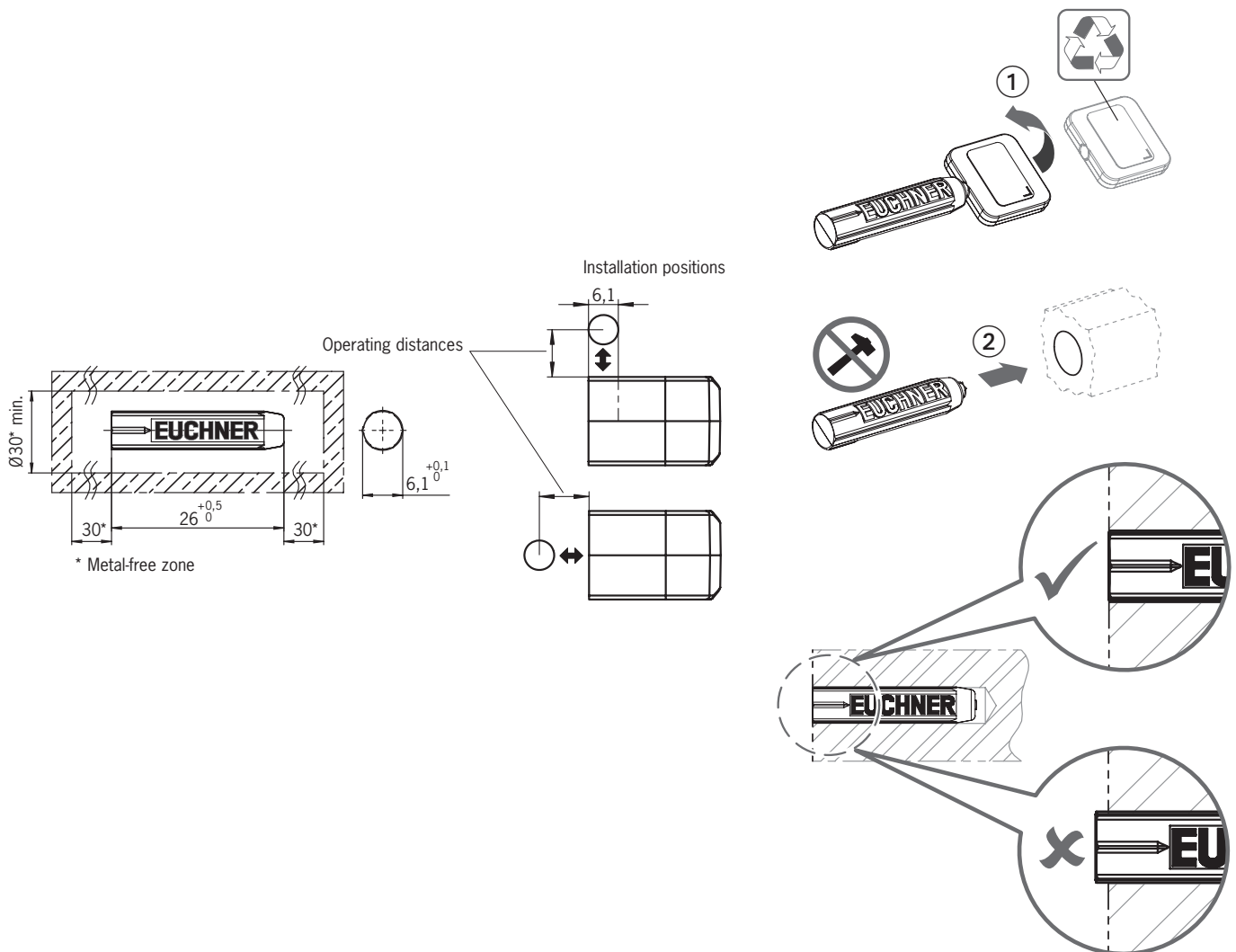

CAUTION

- › Do not mount at temperatures below 0 °C.
- › The actuator can be damaged during mounting.

14.3.2. Operating distances

Operating distance for center offset $m = 0$

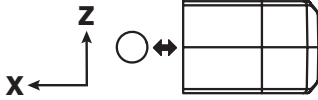
Installation position	Parameter	Value*			Unit
		min.	typ.	max.	
A		min.	typ.	max.	
	Operating distances	-	16	-	mm
	Assured operating distance s_{ao}	13	-	-	
	Switching hysteresis	1	2	-	
	Assured release distance s_{ar} - in x direction	-	-	24	

* The data apply to mounting the actuator in non-metallic surroundings.

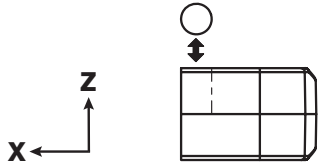
Installation position	Parameter	Value*			Unit
		min.	typ.	max.	
C		min.	typ.	max.	
	Operating distances	-	11	-	mm
	Assured operating distance s_{ao}	6	-	-	
	Switching hysteresis	1	2	-	
	Assured release distance s_{ar} - in z direction	-	-	21	

* The data apply to mounting the actuator in non-metallic surroundings.

14.4. Technical data for A-C11-01-... and A-FLX-C11-05-...

Parameter	Value			Unit
	min.	typ.	max.	
Housing material	Plastic PA6-GF30			
Ambient temperature	- 25	-	+ 70	°C
Degree of protection	IP65/IP67/IP69/IP69K			
Installation position	Active face opposite switch			
Power supply	Inductive via switch			

14.4.1. Dimension drawing

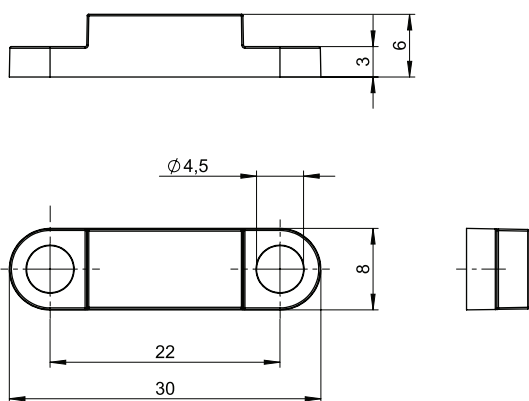

NOTICE

› 2 safety screws M4x8 included.

14.4.2. Operating distances

Operating distance for center offset $m = 0$

Installation position	Parameter	Value			Unit
		min.	typ.	max.	
A 	Operating distances	-	6.5	-	mm
	Assured operating distance s_{ao}	3	-	-	
	Switching hysteresis	1	2	-	
	Assured release distance s_{ar} - in x direction	-	-	13	

Installation position	Parameter	Value			Unit
		min.	typ.	max.	
B 	Operating distances	-	5	-	mm
	Assured operating distance s_{ao} *	2	-	-	
	Switching hysteresis	1	2	-	
	Assured release distance s_{ar} - in z direction	-	-	13	

* Only at an ambient temperature of 0 ... +70 °C

15. Ordering information and accessories



Tip!

Suitable accessories, e.g. cables or assembly material, can be found at www.euchner.com. To order, enter the order number of your item in the search box and open the item view. Accessories that can be combined with the item are listed in *Accessories*.

16. Inspection and service



WARNING

Loss of the safety function because of damage to the device.

- › In case of damage, the entire device must be replaced.
- › Only accessories or spare parts that can be ordered from EUCHNER may be replaced.

Regular inspection of the following is necessary to ensure trouble-free long-term operation:

- › Check the switching function (see chapter 10.4. *Function test on page 20*)
- › Check the secure mounting of the devices and the connections
- › Check for contamination.

No servicing is required. Repairs to the device are only allowed to be made by EUCHNER.

17. Service

If servicing is required, please contact:

EUCHNER GmbH + Co. KG
Kohlhammerstraße 16
70771 Leinfelden-Echterdingen
Germany

Service telephone:

+49 711 7597-500

E-mail:

support@euchner.de

Internet:

www.euchner.com

18. Declaration of conformity

The product complies with the following requirements:

- › Machinery Directive 2006/42/EC (until January 19, 2027)
- › Machinery Regulation (EU) 2023/1230 (from January 20, 2027)

The EU declaration of conformity can be found at www.euchner.com. Enter the order number of your device in the search box. The document is available under *Downloads*.

18.1. Note on Directive 2014/53/EU RED (Radio Equipment Directive) and Delegated Regulation (EU) 2022/30

If this RED-compliant device is integrated into a machine or control system in accordance with the requirements in these instructions, this does not expand or change the device's radio characteristics and therefore does not influence its RED compliance.

EUCHNER GmbH + Co. KG
Kohlhammerstraße 16
70771 Leinfelden-Echterdingen
Germany
info@euchner.de
www.euchner.com

Edition:
MAN20001746-03-04/26
Title:
Operating Instructions Non-Contact Safety Switch
CES-HO-.-C07
(translation of the original operating instructions)
Copyright:
© EUCHNER GmbH + Co. KG, 04/2026

Subject to technical modifications; no responsibility is accepted for the accuracy of this information.