

Correct use

The Safety Contact Expansion ESM-ES3.. in combination with any safety relay from the EUCHNER ESM series can be used to produce up to three additional safety paths per device. An existing system can thus be expanded practically indefinitely in a modular manner. Activation takes place via a safety contact of the safety relay; the ESM-ES3 provides monitoring contacts for error monitoring. The devices can be used in systems up to safety category 4, PL e according to EN ISO 13849-1.

Before the device is used, a risk assessment must be performed on the machine, e.g. according to the following standards:

- ▶ EN ISO 13849-1
- ▶ EN ISO 12100
- ▶ IEC 62061.

Correct use includes observing the relevant requirements for installation and operation, particularly based on the following standards:

- ▶ EN ISO 13849-1
- ▶ EN 60204-1
- ▶ IEC 62061.

Important!

- ▶ The user is responsible for the integration of the device in a safe overall system. For this purpose, the overall system must be validated, e.g. according to EN ISO 13849-2.
- ▶ The device user must assess and document remaining risks.
- ▶ If a data sheet is included with the product, the information on the data sheet applies.

Safety precautions

⚠ WARNING

- ▶ Installation and setup of the device must be performed only by authorized personnel.
- ▶ Observe the country-specific regulations when installing the device.
- ▶ The electrical connection of the device is only allowed to be made with the device isolated.
- ▶ The wiring of the device must comply with the instructions in these operating instructions, otherwise there is a risk that the safety function will be lost.
- ▶ It is not allowed to open the device, tamper with the device or bypass the safety devices.
- ▶ All relevant safety regulations and standards are to be observed.
- ▶ The overall concept of the control system in which the device is incorporated must be validated by the user.
- ▶ Failure to observe the safety regulations can result in death, severe injuries and serious damage.
- ▶ Note down the version of the device (see type label Vx.x.x) and check it each time prior to setup. If the version changes, the use of the device in the overall application must be validated again.

Features

- ▶ 3 safe, redundant relay outputs
1 auxiliary contact (error monitoring)
- ▶ Activation via safety relay from the EUCHNER ESM series
- ▶ Modular, freely configurable safety system
- ▶ Error monitoring by safety relay
- ▶ Ground fault monitoring
- ▶ Indication of the switching state via LED
- ▶ Use up to PL e, SILCL 3, category 4

Function

The Safety Contact Expansion ESM-ES3.. in combination with a safety relay from the EUCHNER ESM series is designed for safe isolation of safety circuits according to EN 60204-1 and can be used up to safety category 4, PL e according to EN ISO 13849-1.

Terminal S11 (DC 24 V control voltage) is connected with terminals S15 and S16 via the safety contacts of the safety relay. Starting the safety relay also activates the ESM-ES3... The safety relay disconnects the control voltage when the safety switch is operated, and the safety contacts of the ESM-ES3.. open immediately.

If a fault occurs in the ESM-ES3.., this is detected by the safety relay via terminals S23 and S24.

Independent operation without safety relay is not possible.

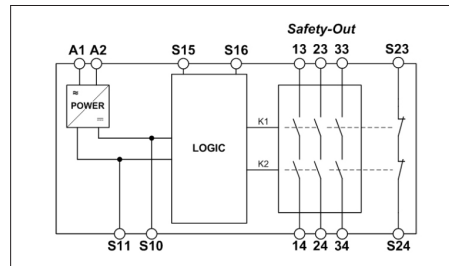

Fig. 1: Block diagram for ESM-ES3..

Mounting

As per EN 60204-1, the device is intended for installation in control cabinets with a minimum degree of protection of IP54. It is mounted on a 35 mm mounting rail according to DIN EN 60715 TH35.

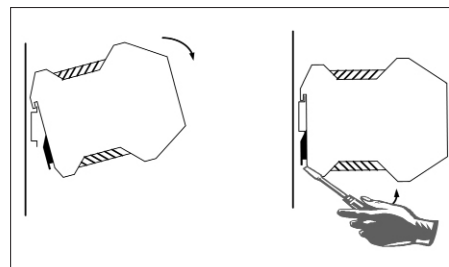

Fig. 2: Mounting/removing

Electrical connection

- ▶ When the 24 V version is used, a safety transformer according to EN 61558-2-6 or a power supply unit with electrical isolation from the mains must be connected.
- ▶ External fusing of the safety contacts must be provided.
- ▶ A maximum length of the control lines of 1,000 m with a conductor cross-section of 0.75 mm² must not be exceeded.
- ▶ The conductor cross-section must not exceed 2.5 mm².
- ▶ If the device does not function after setup, it must be returned to the manufacturer unopened. Opening the device will void the warranty.
- ▶ PE (protective earth) must be connected to terminal S10 on the AC 115/230 V variant. Wiring of the overall device is to be designed for 115/230 V.

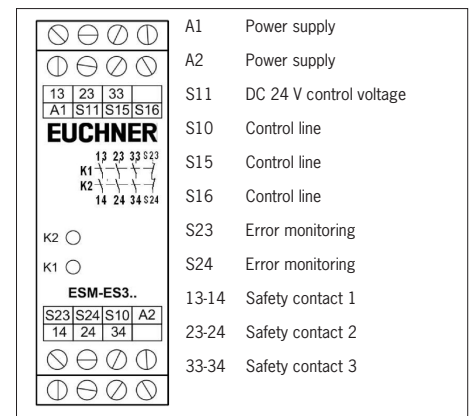

Fig. 3: Connections

Setup procedure

Notice

The items listed under *Electrical connection* must be observed during setup.

1. Wiring ESM-ES3..:

Wire the ESM-ES3.. with the EUCHNER safety relay according to your application (see Fig. 5 and Fig. 6).

2. Wiring safety relay:

Wire the safety relay according to the required Performance Level determined (see operating instructions for the safety relay).

3. Wiring feedback loop:

Wire the feedback loop as shown in Fig. 7 and Fig. 8.

4. Wiring power supply:

Connect the power supply to terminals A1 and A2 (see Fig. 9).

Attention: Wiring only in de-energized state.

5. Starting the device:

Switch the operating voltage on.

Attention: If the *Automatic start* behavior is set on the safety relay, the safety contacts will close immediately.

If the *Monitored manual start* behavior is set, close the start button to close the safety contacts.

The LEDs K1 and K2 on the safety relay and on the ESM-ES3.. illuminate.

6. Activating safety function:

Open the emergency stop circuit by actuating the connected safety switch. The safety contacts of the safety relay and the ESM-ES3.. open immediately.

7. Reactivating:

Close the emergency stop circuit. If *Automatic start* is selected on the safety relay, the safety contacts will close immediately.

If the *Monitored manual start* behavior is set, close the start button on the safety relay to close the safety contacts of the safety relay and the ESM-ES3..

What to do in case of a fault?

Device does not switch on:

- ▶ Check the wiring of the ESM-ES3.. and the safety relay by comparing it with the wiring diagrams (also see operating instructions for the safety relay).
- ▶ Check the safety switch used on the safety relay for correct function and adjustment.
- ▶ Check whether the emergency stop circuit of the safety relay is closed.
- ▶ Check whether the start button on the safety relay (with manual start) is closed.
- ▶ Check the operating voltage at A1 and A2 on the safety relay and on the ESM-ES3...
- ▶ Is the feedback loop closed?

Device cannot be switched on again after an emergency stop:

- ▶ Check whether the emergency stop circuit was closed again.
- ▶ Was the start button opened before closing of the emergency stop circuit (with manual start)?
- ▶ Is the feedback loop closed?
- ▶ Is the power supply present during the time sequence?

If the fault persists, perform the steps listed under *Setup procedure*.

If these steps do not remedy the fault either, return the device to the manufacturer for examination.

Opening the device is impermissible and will void the warranty.

Maintenance

The device must be checked once per month for proper function and for signs of tampering and bypassing of the safety function. The device is otherwise maintenance-free, provided that it was installed properly.

Disposal

Pay attention to the applicable national regulations and laws during disposal.

EU declaration of conformity

The declaration of conformity is part of the operating instructions, and it is included as a separate sheet with the device.

The EU declaration of conformity can also be found at: www.euchner.com

Service

If servicing is required, please contact:

EUCHNER GmbH + Co. KG
Kohlhammerstraße 16
70771 Leinfelden-Echterdingen
Germany

Service telephone:
+49 711 7597-500

E-mail:
support@euchner.de

Internet:
www.euchner.com

Technical data

Parameter	Value		
	ESM-ES301	ESM-ES302	ESM-ES303
Version	ESM-ES301	ESM-ES302	ESM-ES303
Operating voltage	AC/DC 24 V	AC 115 V	AC 230 V
Rated supply frequency		50 - 60 Hz	
Permissible deviation		± 10%	
Power consumption	DC 24 V Approx. 1.2 W	AC 230 V Approx. 3.5 VA	
Control voltage at S11	DC 24 V		
Control current S11 ... S14	Approx. 40 mA		
Safety contacts	3 NO contacts		
Monitoring contacts	1 NC contact (monitoring contact for safety relay)		
Max. switching voltage	AC 250 V		
Safety contact breaking capacity (13-14, 23-24, 33-34)	AC: 250 V, 1.500 VA, 6 A for ohm resistive load 250 V, 4 A for AC-15		
	DC: 24 V, 30 W, 1.25 A for ohm resistive load 24 V, 2 A, for DC-13		
Max. cumulative current of all safety contacts	10.5 A		
Minimum contact load	24 V, 20 mA		
Contact fuses	6 A gG		
Conductor cross-section	0.14 - 2.5 mm ²		
Max. length of control cable	1,000 m with 0.75 mm ²		
Contact material	AgNi		
Mech. contact life	Approx. 1 x 10 ⁷		
Test voltage	2.5 kV (control voltage/contacts)		
Rated impulse withstand voltage, leakage paths/air gaps	4 kV (DIN VDE 0110-1)		
Rated insulation voltage	250 V		
Degree of protection	IP20		
Temperature range	DC 24 V: -15 °C to +60 °C		
	AC 230 V/115 V/24 V: -15 °C to +40 °C		
Degree of contamination	2 (DIN VDE 0110-1)		
Overvoltage category	3 (DIN VDE 0110-1)		
Weight	Approx. 230 g		
Mounting	Mounting rail according to DIN EN 60715 TH35		
Reliability values according to EN ISO 13849-1 for all variants of the series ESM-ES3¹⁾			
Load (DC-13; 24 V)	≤ 0.1 A	≤ 1 A	≤ 2 A
n _{op}	≤ 400,000 cycles	≤ 73,000 cycles	≤ 17,000 cycles
T _{10D}	20 years		
Category	4		
PL	e		
PFH _D	1.2 x 10 ⁻⁸ 1/h		

1) Additional data can be requested from the manufacturer for applications that deviate from these conditions.

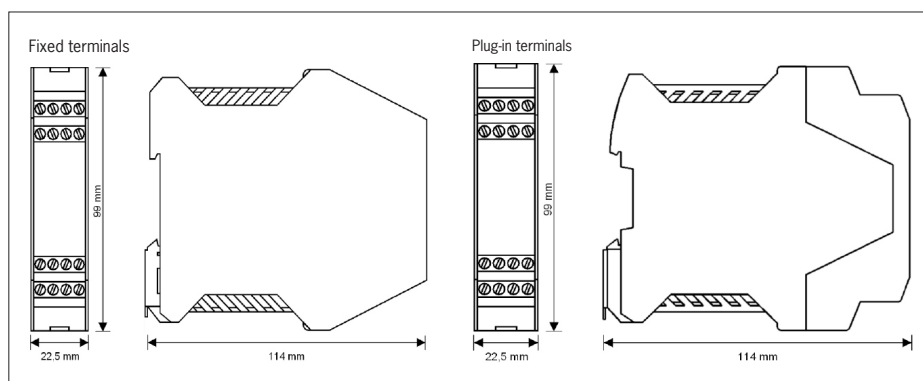

Fig. 4: Dimension drawing for ESM-ES3..

Applications

Depending on the application, the device must be wired with a EUCHNER safety relay as shown in Fig. 5 and Fig. 6.

If the devices are wired inside a control cabinet (minimum degree of protection IP54), the fault involving a short circuit between the activation lines can be ruled out (protected wiring space). Category 4, PL e according to EN ISO 13849-1 is thereby possible.

If this fault cannot be ruled out, category 3, PL e is achieved.

Wiring

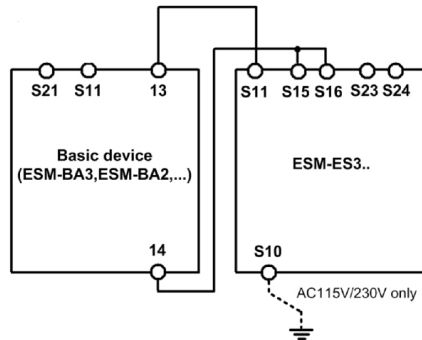

Fig. 5: Connection of ESM-ES3.. to safety relay

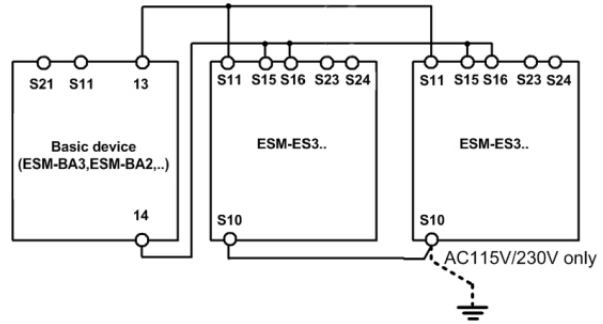

Fig. 6: Connection of several ESM-ES3.. units to safety relay

Wiring of the ESM-ES3.. via only 4 lines:

A safety contact of the safety relay (e.g. 13 - 14) activates the relays of the ESM-ES3.. (S11 and S15 / S16).

Two lines on S23 and S24 are required for feedback/error monitoring. This is to be wired, depending on the application, as per Fig. 7 or Fig. 8.

An error in the ESM-ES3.. thereby prevents the entire safety chain from restarting. Earth faults in the control lines are detected in addition to internal faults.

Notice:

In order to activate ground fault monitoring, S10 must be connected to PE (protective earth) on the AC115/230 V devices. With AC/DC 24 V, connect PE only to the power supply unit according to EN 60204-1.

Feedback loop

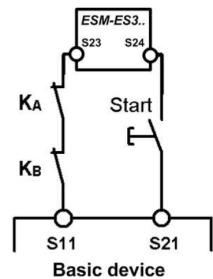

Fig. 7: Feedback loop.

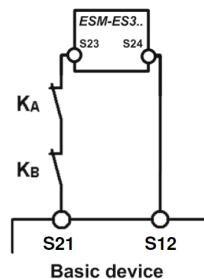

Fig. 8: Feedback loop with automatic start.

Contactors connected to the ESM-ES3.. or the safety relay are monitored via the feedback loop of the safety relay. KA and KB are the positively driven contacts of the connected contactor or expansion module.

Contactors connected to the ESM-ES3.. or the safety relay are monitored via the feedback loop of the safety relay. KA and KB are the positively driven contacts of the connected contactor or expansion module.

Power supply and safety contacts

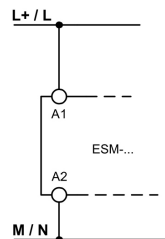

Fig. 9: Connection of the power supply to terminals A1 and A2 (power supply according to the technical data).

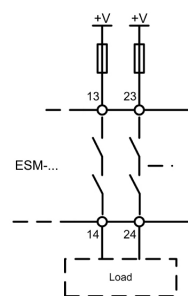

Fig. 10: Connection to switching loads on safety contacts (example contact configuration. Differing according to device type. Switching voltages +V corresponding to technical data).