

Correct use

The ESM-BA2.. is a universal safety emergency stop switching device with two safe relay outputs that can quickly and safely stop the moving parts of a machine or installation in case of danger.

Applications for the ESM-BA2.. include single- or dual-channel emergency stop circuits and guard monitoring on machines and installations.

Before the device is used, a risk assessment must be performed on the machine, e.g. in accordance with the following standards:

- ▶ EN ISO 13849-1
- ▶ EN ISO 12100
- ▶ IEC 62061.

Correct use includes observing the relevant requirements for installation and operation, particularly based on the following standards:

- ▶ EN ISO 13849-1
- ▶ EN 60204-1
- ▶ IEC 62061.

Important!

- ▶ The user is responsible for the integration of the device in a safe overall system. For this purpose, the overall system must be validated, e.g. in accordance with EN ISO 13849-2.
- ▶ The device user must assess and document remaining risks.
- ▶ If a data sheet is included with the product, the information on the data sheet applies.

Safety precautions

⚠ WARNING

- ▶ Installation and setup of the device must be performed only by authorized personnel.
- ▶ Observe the country-specific regulations when installing the device.
- ▶ The electrical connection of the device is only allowed to be made with the device isolated.
- ▶ The wiring of the device must comply with the instructions in these operating instructions, otherwise there is a risk that the safety function will be lost.
- ▶ It is not allowed to open the device, tamper with the device or bypass the safety devices.
- ▶ All relevant safety regulations and standards are to be observed.
- ▶ The overall concept of the control system in which the device is incorporated must be validated by the user.
- ▶ Failure to observe the safety regulations can result in death, severe injuries and serious damage.
- ▶ Note down the version of the device (see type label Vx.x.x) and check it each time prior to setup. If the version changes, the use of the device in the overall application must be validated again.

Features

- ▶ 2 safe, redundant relay outputs
- ▶ Connection of:
 - Emergency stop buttons
 - Safety switches
 - Non-contact safety switches
 - Safety components with OSSD outputs
- ▶ Single- and dual-channel operation possible
- ▶ Feedback loop for monitoring downstream contactors or expansion modules
- ▶ Cyclical monitoring of the output contacts
- ▶ Indication of the switching state via LED
- ▶ 2 start behaviors possible:
 - Monitored manual start
 - Automatic start
- ▶ Use up to PL e, SILCL 3, category 4

Function

The safety emergency stop switching device ESM-BA2.. is designed for safe isolation of safety circuits according to EN 60204-1 and can be used up to safety category 4, PL e according to EN ISO 13849-1.

The internal logic system closes the safety contacts when the start button is pressed.

When the safety switch is opened, the positively driven safety contacts are opened and safely switch the machine off. It is ensured that a single fault does not lead to a loss of the safety function and that every fault is detected by cyclical self-monitoring no later than when the system is switched off and switched on again.

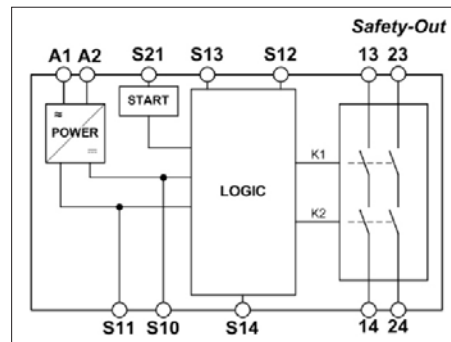

Fig. 1: Block diagram for ESM-BA2..

Mounting

As per EN 60204-1, the device is intended for installation in control cabinets with a minimum degree of protection of IP54. It is mounted on a 35 mm mounting rail according to DIN EN 60715 TH35.

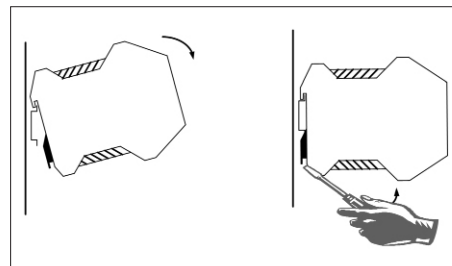

Fig. 2: Mounting/removing

Electrical connection

- ▶ When the 24 V version is used, a safety transformer according to EN 61558-2-6 or a power supply unit with electrical isolation from the mains must be connected.
- ▶ External fusing of the safety contacts must be provided.
- ▶ A maximum length of the control lines of 1,000 meters with a conductor cross-section of 0.75 mm² must not be exceeded.
- ▶ The conductor cross-section must not exceed 2,5 mm².
- ▶ If the device does not function after setup, it must be returned to the manufacturer unopened. Opening the device will void the warranty.

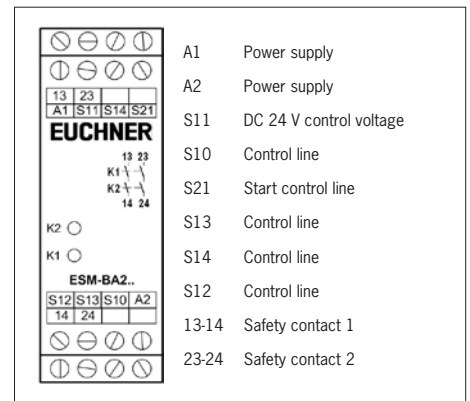

Fig. 3: Connections

Setup procedure

Notice

The items listed under *Electrical connection* must be observed during setup.

1. Wiring emergency stop circuit:

Wire the emergency stop circuit according to the required Performance Level determined (see Fig. 5 to Fig. 9).

2. Wiring start circuit:

Wire the start circuit according to Fig. 10 or Fig. 11 to set the starting behavior.

Attention: If *Automatic start* is set, bear in mind that the safety contacts will switch immediately after the power supply is connected. If *Monitored manual start* is set, the start button must be opened after wiring.

3. Wiring feedback loop:

If your application provides for external contactors or expansion modules, connect them to the device according to Fig. 12 or Fig. 13.

4. Wiring power supply:

Connect the power supply to terminals A1 and A2 (see Fig. 14).

Attention: Wiring only in de-energized state.

5. Starting the device:

Switch the operating voltage on.

Attention: if the *Automatic start* behavior is set, the safety contacts will close immediately.

If the *Monitored manual start* behavior is set, close the start button to close the safety contacts.

LEDs K1 and K2 illuminate.

6. Activating safety function:

Open the emergency stop circuit by actuating the connected safety switch. The safety contacts open immediately.

7. Reactivation:

Close the emergency stop circuit. If *Automatic start* is selected, the safety contacts will close immediately.

If the *Monitored manual start* behavior is set, close the start button to close the safety contacts.

What to do in case of a fault?

Device does not switch on:

- ▶ Check the wiring by comparing it to the wiring diagrams.
- ▶ Check the safety switch used for correct function and adjustment.
- ▶ Check whether the emergency stop circuit is closed.
- ▶ Check whether the start button (with manual start) is closed.
- ▶ Check the operating voltage at A1 and A2.
- ▶ Is the feedback loop closed?

Device cannot be switched on again after an emergency stop:

- ▶ Check whether the emergency stop circuit was closed again.
- ▶ Was the start button opened before closing of the emergency stop circuit (with manual start)?
- ▶ Is the feedback loop closed?

If the fault persists, perform the steps listed under *Setup procedure*.

If these steps do not remedy the fault either, return the device to the manufacturer for examination.

Opening the device is impermissible and will void the warranty.

Maintenance

The device must be checked once per month for proper function and for signs of tampering and bypassing of the safety function. The device is otherwise maintenance-free, provided that it was installed properly.

Disposal

Pay attention to the applicable national regulations and laws during disposal.

EU declaration of conformity

The declaration of conformity is part of the operating instructions, and it is included as a separate sheet with the device.

The EU declaration of conformity can also be found at: www.euchner.com

Service

If servicing is required, please contact:

EUCHNER GmbH + Co. KG
Kohlhammerstraße 16
70771 Leinfelden-Echterdingen
Germany

Service telephone:
+49 711 7597-500

E-mail:
support@euchner.de

Internet:
www.euchner.com

Technical data

Parameter	Value		
	ESM-BA201	ESM-BA202	ESM-BA203
Version			
Operating voltage	AC/DC 24 V	AC 115V	AC 230 V
Rated supply frequency		50 - 60 Hz	
Permissible deviation		± 10%	
Power consumption	DC 24 V Approx. 1.5 W	AC 230 V Approx. 3.7 VA	
Control voltage at S11	DC 24 V		
Control current S11 ... S14	Approx. 40 mA		
Safety contacts	2 NO contacts		
Max. switching voltage	AC 250 V		
Safety contact breaking capacity (13-14, 23-24)	AC: 250 V, 1,500 VA, 6 A for ohm resistive load (6 operating cycles/minute) 250 V, 3 A for AC-15		
	DC: 24 V, 144 W, 6 A for ohm resistive load (6 operating cycles/minute) 24 V, 3 A, for DC-13		
Minimum contact load	24 V, 20 mA		
Contact fuses	10 A gG		
Conductor cross-section	0.14 - 2.5 mm ²		
Max. length of control cable	1,000 m with 0.75 mm ²		
Contact material	AgSnO ₂		
Mech. contact life	Approx. 1 x 10 ⁷		
Test voltage	2.5 kV (control voltage/contacts)		
Rated impulse withstand voltage, leakage paths/air gaps	4 kV (DIN VDE 0110-1)		
Rated insulation voltage	250V		
Degree of protection	IP20		
Temperature range	DC 24 V: -15 °C to +60 °C ¹⁾ AC 230 V / 115 V / 24 V: -15 °C to +40 °C		
Degree of contamination	2 (DIN VDE 0110-1)		
Overvoltage category	3 (DIN VDE 0110-1)		
Weight	Approx. 230 g		
Mounting	Mounting rail according to DIN EN 60715 TH35		
Reliability values according to EN ISO 13849-1 for all variants of the series ESM-BA2²⁾			
Load (DC-13; 24 V)	≤ 0.1 A	≤ 1 A	≤ 3 A
n _{op}	≤ 400,000 cycles	≤ 100,000 cycles	≤ 22,500 cycles
T _{10D}	20 years		
Category	4		
PL	e		
PFH _b	1.2 x 10 ⁻⁸ 1/h		

1) 20% undervoltage: T_{max} = 50 °C.

2) Additional data can be requested from the manufacturer for applications that deviate from these conditions.

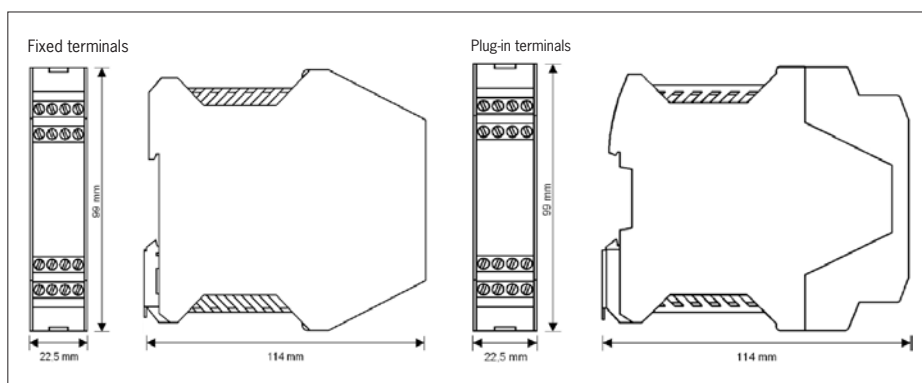

Fig. 4: Dimension drawing for ESM-BA2..

Applications

Depending on the application or the result of the risk assessment according to DIN EN ISO 13849 1, the device must be wired as shown in Fig. 5 to Fig. 15.

Emergency stop circuit

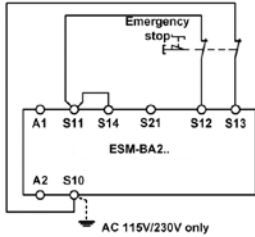

Fig. 5: Dual-channel emergency stop circuit with short circuit and ground fault monitoring (category 4, up to PL e).

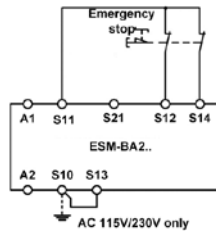

Fig. 6: Dual-channel emergency stop circuit with ground fault monitoring (category 3, up to PL d).

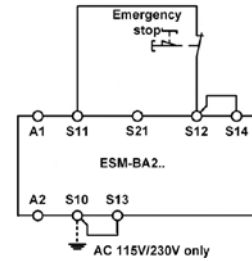

Fig. 7: Single-channel emergency stop circuit with ground fault monitoring (category 1, up to PL c).

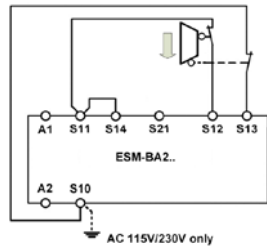

Fig. 8: Dual-channel sliding guard monitoring with short circuit and ground fault monitoring (category 4, up to PL e).

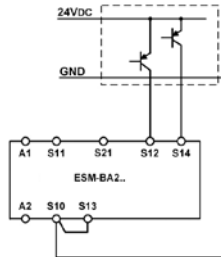

Fig. 9: Dual-channel emergency stop circuit with pnp semiconductor outputs/OSSD outputs with short circuit detection (category 4, up to PL e).

Notice:

In order to activate ground fault monitoring, S10 must be connected to PE (protective earth) on the AC115/230V devices. With AC/DC 24 V, connect PE only to the power supply unit according to EN 60204-1.

Wire the start circuit in accordance with the application according to Fig. 10 or Fig. 11.

Starting behavior

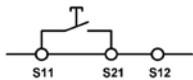

Fig. 10: Monitored manual start. It is monitored that the start button was opened before the emergency stop buttons close (pre-requisite: operating voltage must not be interrupted).



Fig. 11: Automatic start. Max perm. delay during closing of the safety switches on S12 and S13:
S12 before S13: 300 ms
S13 before S12: any

Feedback loop

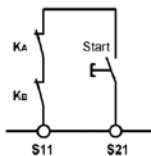

Fig. 12: Feedback loop. Monitoring of externally connected contactors or expansion modules.

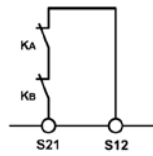

Fig. 13: Feedback loop with automatic start. Monitoring of externally connected contactors or expansion modules.

Power supply and safety contacts

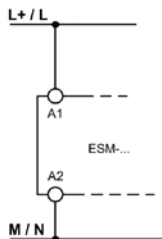

Fig. 14: Connection of the power supply to terminals A1 and A2 (power supply according to the technical data).

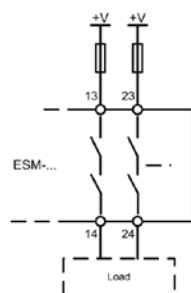

Fig. 15: Connection to switching loads on safety contacts (example contact configuration. Differing according to device type. Switching voltages +V corresponding to technical data).