

# EUCHNER

## Operating Instructions

Non-Contact Safety Switch  
CES-AH-C03-AE-LS (Unicode)

EN

## Contents

<b>1.</b>	<b>About this document</b> .....	<b>4</b>
1.1.	Scope.....	4
1.2.	Target group .....	4
1.3.	Key to symbols.....	4
1.4.	Supplementary documents .....	4
<b>2.</b>	<b>Correct use</b> .....	<b>5</b>
<b>3.</b>	<b>Description of the safety function</b> .....	<b>6</b>
<b>4.</b>	<b>Exclusion of liability and warranty</b> .....	<b>6</b>
<b>5.</b>	<b>General safety precautions</b> .....	<b>6</b>
<b>6.</b>	<b>Function</b> .....	<b>7</b>
<b>7.</b>	<b>Mounting</b> .....	<b>8</b>
<b>8.</b>	<b>Electrical connection</b> .....	<b>9</b>
8.1.	General notes.....	9
8.2.	Test pulses, pulsing and power control .....	9
8.3.	Fault behavior.....	9
8.4.	Automatic restart and start button .....	10
8.5.	Safety in case of faults.....	10
8.6.	Fuse protection for power supply .....	10
8.7.	Voltage drop on cables and switch .....	10
8.7.1.	Calculation example .....	10
8.8.	Connecting cables and plug connectors .....	11
8.9.	Connector assignment of safety switch CES-AH .....	12
8.10.	Connection of the CES-AH .....	12
<b>9.</b>	<b>Setup</b> .....	<b>13</b>
9.1.	LED displays .....	13
9.2.	Teach-in function for actuator.....	13
9.2.1.	Carrying out teach-in for a new actuator .....	13
9.3.	Functional check.....	14
<b>10.</b>	<b>System status table</b> .....	<b>15</b>
<b>11.</b>	<b>Technical data</b> .....	<b>16</b>
11.1.	Technical data for safety switch CES-AH-C03-AE-LS .....	16
11.2.	Typical system times.....	18
11.3.	Dimension drawing and connector assignment.....	19
11.4.	Technical data for actuator CES-A-BRN .....	20
11.4.1.	Dimension drawing.....	20
11.4.2.	Operating distances .....	21

12.	Ordering information and accessories .....	22
13.	Inspection and service .....	22
14.	Service .....	22
15.	Declaration of conformity .....	23

## 1. About this document





### 1.1. Scope

These operating instructions are valid for safety switch CES-AH-C03-AE-LS. These operating instructions, the document *Safety information* and any enclosed data sheet form the complete user information for your device.

### 1.2. Target group



Design engineers and installation planners for safety devices on machines, as well as setup and servicing staff possessing special expertise in handling safety components.

### 1.3. Key to symbols

Symbol/depiction	Meaning
	Printed document
	Document is available for download at <a href="http://www.euchner.com">www.euchner.com</a>
 <b>DANGER</b> <b>WARNING</b> <b>CAUTION</b>	Safety precautions <b>Danger</b> of death or severe injuries <b>Warning</b> about possible injuries <b>Caution</b> slight injuries possible
 <b>NOTICE</b> <b>Important!</b>	<b>Notice</b> about possible device damage <b>Important</b> information
<b>Tip</b>	Useful information

### 1.4. Supplementary documents

The overall documentation for this device consists of the following documents:

Document title (document number)	Contents	
Safety information (2525460)	Basic safety information	
Operating instructions (2105267)	(this document)	
Possibly enclosed data sheet	Item-specific information about deviations or additions	

	<b>Important!</b> Always read all documents to gain a complete overview of safe installation, setup and use of the device. The documents can be downloaded from <a href="http://www.euchner.com">www.euchner.com</a> . For this purpose enter the doc. no. in the search box.
---	--

### 2. Correct use

Safety switches series CES-AH-C03-AE-LS are interlocking devices without guard locking (type 4). The device meets the requirements according to EN IEC 60947-5-3, except for section 8.6. Devices with unicode evaluation possess a high coding level.

In combination with a movable guard and the machine control, this safety component prevents dangerous machine functions from occurring while the guard is open. A stop command is triggered if the guard is opened during the dangerous machine function.

This means:

- Starting commands that cause a dangerous machine function must become active only when the guard is closed.
- Opening the guard triggers a stop command.
- Closing a guard must not cause automatic starting of a dangerous machine function. A separate start command must be issued. For exceptions, refer to EN ISO 12100 or relevant C-standards.

Before the device is used, a risk assessment must be performed on the machine, e.g. in accordance with the following standards:

- EN ISO 13849-1
- EN ISO 12100
- IEC 62061

Devices in the system family CES-AH... have special safety outputs that are suitable for the direct switching of large loads. In appropriate applications it is therefore not necessary to connect power relays or contactors in between.

The device interrupts the supply of power to the load, if, e.g., the guard is open.

Correct use includes observing the relevant requirements for installation and operation, particularly based on the following standards:

- EN ISO 13849-1
- EN ISO 14119
- EN 60204-1

The safety switch is only allowed to be operated in conjunction with the intended EUCHNER CES actuators and the related connection components from EUCHNER. On the use of different actuators or other connection components, EUCHNER provides no warranty for safe function.



#### Important!

- The user is responsible for the proper integration of the device into a safe overall system. For this purpose, the overall system must be validated, e.g. in accordance with EN ISO 13849-2.
- It is only allowed to use components that are permissible in accordance with the table below.

Table 1: Possible combinations for CES components

Safety switch	Actuator	
	CES-A-BRN-100251 100 251	
CES-AH-C03-AE-LS...	32	
Key to symbols	25	Combination possible, typ. operating distance 20 mm
		Combination possible, guard locking for process protection
		Combination possible, guard locking for personnel protection
		Combination not permissible

### 3. Description of the safety function

Devices from this series feature the following safety functions:

#### Monitoring of the guard position (interlocking device according to EN ISO 14119)

- Safety function:
  - The safety outputs are switched off when the guard is open.
- Safety characteristics: category, Performance Level, PFH<sub>D</sub> (see chapter 11. *Technical data on page 16*).

### 4. Exclusion of liability and warranty

In case of failure to comply with the conditions for correct use stated above, or if the safety regulations are not followed, or if any servicing is not performed as required, liability will be excluded and the warranty void.

### 5. General safety precautions

Safety switches fulfill personnel protection functions. Incorrect installation or tampering can lead to fatal injuries to personnel.

Check the safe function of the safeguard particularly

- after any setup work
- after the replacement of a system component
- after an extended period without use
- after every fault

Independent of these checks, the safe function of the safeguard should be checked at suitable intervals as part of the maintenance schedule.



#### **WARNING**

Danger to life due to improper installation or due to bypassing (tampering). Safety components fulfill a personnel protection function.

- Safety components must not be bypassed, turned away, removed or otherwise rendered ineffective. On this topic pay attention in particular to the measures for reducing the possibility of bypassing according to EN ISO 14119:2013, section 7.
- The switching operation must be triggered only by actuators designated for this purpose.
- Prevent bypassing by means of replacement actuators (only for multicode evaluation). For this purpose, restrict access to actuators and to keys for releases, for example.
- Mounting, electrical connection and setup only by authorized personnel possessing the following knowledge:
  - specialist knowledge in handling safety components
  - knowledge about the applicable EMC regulations
  - knowledge about the applicable regulations on operational safety and accident prevention.



#### **Important!**

Prior to use, read the operating instructions and keep these in a safe place. Ensure the operating instructions are always available during mounting, setup and servicing. For this reason you should archive a printed copy of the operating instructions. You can download the operating instructions from [www.euchner.com](http://www.euchner.com).

### 6. Function

The safety switch **CES-AH-C03-AE-LS** complies with the following safety requirements:

- › Category 3 according to DIN EN ISO 13849-1
- › Redundant design of the circuit in the unit with self-monitoring
- › This means that the safety system still functions even if an internal component fails
- › The switching state of the semiconductor outputs is continuously monitored internally

The non-contact safety switch **CES** consists of three components: coded actuator, evaluation unit and read head.

The evaluation unit is integrated into a housing with the read head.

Each transponder actuator from EUCHNER features coding that far surpasses the requirements in EN ISO 14119 for a type 4 switch with high coding level. The code in an actuator cannot be reprogrammed.

The actuator must be assigned to the safety switch by a teach-in operation so that it is detected by the system. This unambiguous assignment ensures a particularly high level of protection against tampering.

The safety switch with integrated evaluation unit and read head is fastened to the fixed part of the guard.

The actuator attached to the movable part of the guard is moved towards the read head fitted in the safety switch by closing the door. When the operating distance is reached, power is supplied to the actuator by the inductive read head and data can be transferred.

The bit pattern read is compared with the code saved in the safety switch. If the data match, the safety outputs are enabled.

Due to the combination of dynamic polling of the actuator and the redundant, diverse design of the safety electronics with the two feedback switching elements for each safety output, the safety switch will enter the safe state with every detectable fault.

The safety outputs shut down the safety circuits if the guard is opened. The state of the safety outputs is monitored internally by two microprocessors.

For the safety outputs to switch on, there must be a voltage of  $U_B$  on the START input. This voltage can be supplied either using a jumper (automatic start) or using a start button.

The safety switch has a redundant circuit design with self-monitoring. This means that the safety system is still effective even if a component fails.

The system is designed so that a failure will not result in the loss of the safety function. The occurrence of failures is detected by cyclic self-monitoring at the latest on the next demand to close the safety contacts (e.g. on starting).

## 7. Mounting



### CAUTION

Risk of damage to equipment as a result of incorrect installation. Safety switches must not be used as a mechanical end stop.

- › Fit an additional end stop for the movable part of the guard.



### Important!

- › From the assured release distance  $S_{ar}$ , the safety outputs are safely shut down.
- › When mounting several safety switches, observe the stipulated minimum distance to avoid mutual interference.

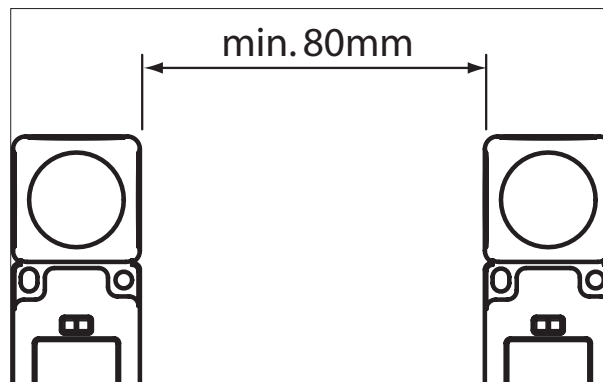

- › If the actuator is installed flush, the operating distances change as a function of the installation depth and the guard material.

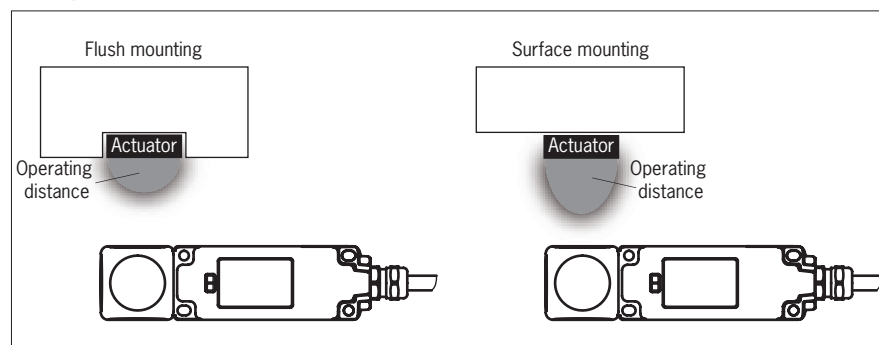

Note the following points:

- › Actuator and safety switch must be easily accessible for inspection and replacement.
- › Actuator and safety switch must be fitted so that
  - the front faces are at the minimum operating distance  $0.8 \times S_{ao}$  or closer when the guard is closed (see section *Actuating ranges*). For a side approach direction for the actuator a minimum distance must be maintained so that the actuating range of the side lobes is not entered (see actuating range for the actuator).
  - when the guard is open up to the distance  $S_{ar}$  (assured release distance), a hazard is excluded.
  - the actuator is positively mounted on the guard, e.g. by using the safety screws included.



## 8. Electrical connection

### 8.1. General notes



#### CAUTION

- Risk of damage to equipment or malfunctions as a result of incorrect connection.
- › The switch was developed for special installation conditions in construction machines. The company distributing the installation must verify conformity with the EMC directive, taking the applicable standards into account. All conducted disturbances that, according to section 4.9 of EN 13309, can occur in power supplies must be filtered by upstream protective devices. Impermissibly high voltage peaks on UB will damage the switch.
  - › To avoid faults, the cable must be laid with protection.
  - › The power for the operating voltage and for the inputs +LA and +LB must be provided from a common power supply.
  - › All the electrical connections must either be isolated from the mains supply by a safety transformer according EN IEC 61558-2-6 with limited output voltage in the event of a fault, or by other equivalent insulation measures.
  - › With inductive loads there can be voltage spikes of up to -50 V lasting several milliseconds on switching off the outputs.
  - › To prevent overvoltages on the inputs and outputs for the safety circuits, inductive loads must be connected with free-wheeling diodes (see chapter 8.10. *Connection of the CES-AH on page 12*).
  - › Power devices which are a powerful source of interference must be installed in a separate location away from the input and output circuits for signal processing. The cable routing for safety circuits should be as far away as possible from the cables of the power circuits.

### 8.2. Test pulses, pulsing and power control



#### Important!

- › In operation the device regularly switches off the safety outputs for approx. 6 ms to check the safe switching function. The loads connected must tolerate this behavior.
- › A load connected is controlled using the safety paths +LA/LA and +LB/LB. The control voltage can be pulsed for power control.
- › Do not use a control system with pulsing to test the output cables or switch off the pulsing function in your control system.

### 8.3. Fault behavior



#### CAUTION

- › In the event of a fault in the safety switch, the safety circuit is switched off and the DIA LED illuminates red.
- › After approx. 5 s the device performs a re-start.



#### Important!

If the device does not appear to function when operating voltage is applied (e.g. green STATE LED does not flash), the safety switch must be returned unopened to the manufacturer.

## 8.4. Automatic restart and start button

Pay attention to the notes for the following applications:

### Automatic start, with a jumper

(+24 V is continuously present at the START input)

- ➔ The device restarts automatically after faults.

### Manual start (start via start button)

- ➔ The start button must be pressed after each restart.
- › A sticking start button (fault due to welding, etc.) is not detected by the device and results in an automatic restart.



### DANGER

Danger due to automatic start/restart.

An automatic start/restart can occur:

- › On closing the guard
- › On switching on the power supply
- › On automatic restart after the detection of a fault
  
- › Check carefully which start mode is suitable for your application.
- › Check whether additional measures are necessary to prevent an automatic restart.

## 8.5. Safety in case of faults

- › The operating voltage  $U_B$  is reverse polarity protected.
- › The contacts +LA/LA and +LB/LB are short circuit-proof and protected against reverse polarity.
- › To prevent switching on of the load connected in the case of a short circuit between LA or LB and the operating voltage  $U_B$ , the cables must be laid rigidly and with protection.

## 8.6. Fuse protection for power supply

The power supply must be provided with fuse protection depending on the current required for the outputs. If both outputs (LA and LB) are used, protect with a max. 10 A fuse.

## 8.7. Voltage drop on cables and switch

If a load is applied to the outputs, voltage drops will occur on the supply cables and on the switch.

The voltage drops are to be taken into account during the calculation of the power available in the load connected.

Parameter	Value	Unit
Maximum resistance of an output path	250	mΩ
Resistance for further connecting cable (e.g. 7 x 1 mm <sup>2</sup> , supply and return cables)	25	mΩ/m

Other connection resistances are to be taken into account as necessary.

### 8.7.1. Calculation example

- › 10 m cable from the switch to the supply/load
- › Supply voltage on the 24 V connection
- › Load on channel A: 1 A
- › Load on channel B: 4 A

### For channel A:

› Voltage drop on the switch

$$\Delta U_1 = R \times I = 250 \text{ m}\Omega \times 1 \text{ A} = 250 \text{ mV}$$

› Voltage drop on the cable

$$\Delta U_2 = R_l \times s \times I = 25 \text{ m}\Omega/\text{m} \times 10 \text{ m} \times 1 \text{ A} = 250 \text{ mV}$$

› Voltage at the load

$$U = U_B - \Delta U_1 - \Delta U_2 = 24 \text{ V} - 0.25 \text{ V} - 0.25 \text{ V} = 23.5 \text{ V}$$

### For channel B:

› Voltage drop on the switch

$$\Delta U_1 = R \times I = 250 \text{ m}\Omega \times 4 \text{ A} = 1 \text{ V}$$

› Voltage drop on the cable

$$\Delta U_2 = R_l \times l \times I = 25 \text{ m}\Omega/\text{m} \times 8 \text{ m} \times 4 \text{ A} = 800 \text{ mV}$$

› Voltage at the load

$$U = U_B - \Delta U_1 - \Delta U_2 = 24 \text{ V} - 1 \text{ V} - 0.8 \text{ V} = 22.2 \text{ V}$$

## 8.8. Connecting cables and plug connectors



### CAUTION

Risk of damage to equipment or malfunctions as a result of incorrect connecting cables.

- › Use EUCHNER connectors.
- › If other connection components are used, the following recommendations apply. EUCHNER provides no warranty for safe function in case of failure to comply with these requirements.
- › The maximum cable length should not exceed 50 m.

### Recommended connecting cable:

e.g. LiYY 7 x 1mm<sup>2</sup>,

Ölflex classic 400P 7 x 0.75

### Terminating plug for the mating side:

AMP Superseal series, manufacturer Tyco/AMP

Component	AMP order number	Required quantity
Socket contact (for conductor cross-sections 0.75 ... 1.5 mm <sup>2</sup> )	183025-1	7
Socket housing 3-pin	282087-1	1
Socket housing 4-pin	282088-1	1
Individual core seals depending on core diameter:		Total 7
1.4 ... 1.7 mm    green	281934-4	
1.8 ... 2.4 mm    yellow	281934-2	
2.6 ... 3.3 mm    red	281934-3	



### Important!

It is imperative you use the original tools from the connector manufacturer for assembly and follow the assembly instructions from the connector manufacturer.

### 8.9. Connector assignment of safety switch CES-AH

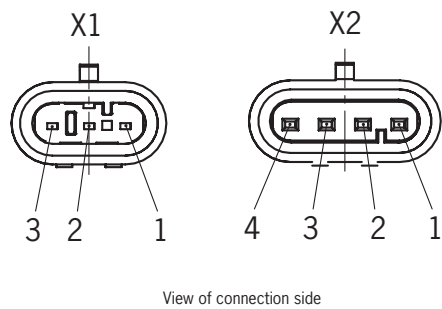
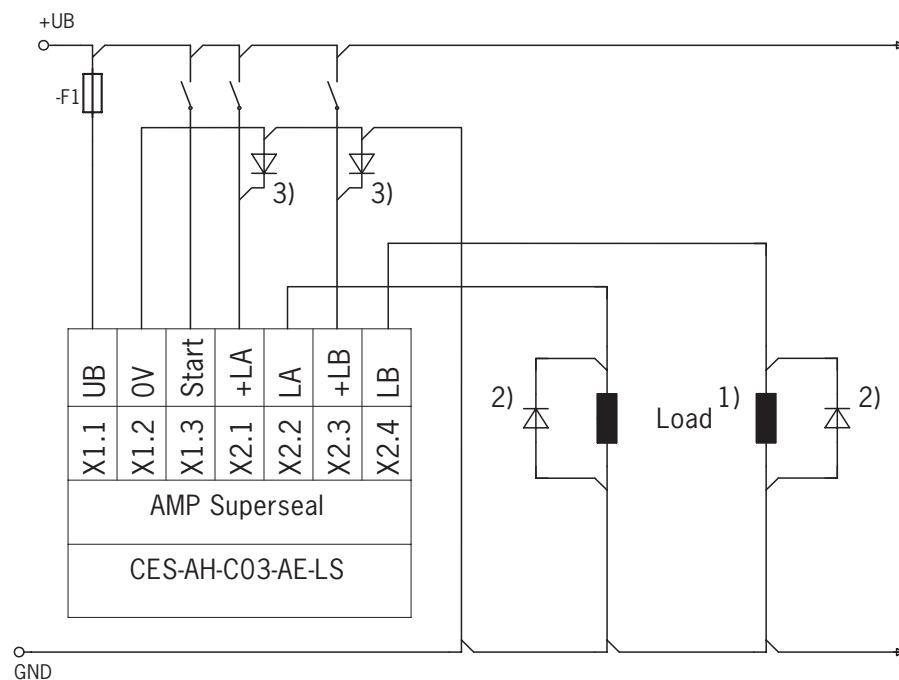

Figure 1: Connector assignment of safety switch CES-AH

Plug	Pin	Designation	Description	Core color / core number
X1	1	UB	Power supply, DC 24 V	BN / 3
	2	0 V	Ground, DC 0 V	BU / 1
	3	Start	Start input	WH / 2
X2	1	+LA	Input for channel 1	GY / 6
	2	LA	Safety output, channel 1	PK / 7
	3	+LB	Input for channel 2	YE / 5
	4	LB	Safety output, channel 2	GN / 4

### 8.10. Connection of the CES-AH



- 1) Load, e.g. valve coil, DC motor, ohmic load, etc.
- 2) In case of inductive loads, it is imperative free-wheeling diodes are used to protect the outputs on the safety switch.
- 3) Alternative connection of the free-wheeling diodes with inductive loads

Figure 2: Connection of CES-AH



**CAUTION**

Use the alternative connection only if your specific application has been checked and approved by EUCHNER.





### CAUTION

- ▶ A short circuit between the cables on the safety outputs LA and LB and another cable must be prevented.
- ▶ In certain circumstances, fault exclusion as per EN 13849-1, section 7.3, can be applied; see also EN 13849-2, section D.5.2.
- ▶ The CES-AH represents a subsystem as per EN 13849-1 and complies with PL d. To integrate the switch in a category 3 structure, it is necessary to monitor the downstream load (the feedback loop must be monitored).
- ▶ This example shows only an excerpt that is relevant for connection of the CES AH system. The example illustrated here does not show complete system planning. The user is responsible for safe integration into the overall system.

## 9. Setup

### 9.1. LED displays

LED	Color	State	Meaning
STATE	green	illuminated 	Normal operation
		flashing 	Teach-in operation or power-up (for further signal function see status table)
DIA	red	illuminated 	- Internal electronics fault - Fault at the inputs/outputs

### 9.2. Teach-in function for actuator

The actuator must be allocated to the safety switch using a teach-in function before the system forms a functional unit. During a teach-in operation, the safety outputs are in high-resistance state, i.e. the system is in the safe state.



### Important!

- ▶ The safety switch disables the code of the preceding device if teach-in is carried out for a new actuator. Teach-in is not possible again immediately for this device if a new teach-in operation is carried out. The disabled code is deleted again in the safety switch only after a third code has been taught.
- ▶ The safety switch can be operated only with the last actuator taught-in.
- ▶ If the switch detects an actuator that has already been taught when in teach-in standby state, this state is ended immediately and the switch changes to normal state.
- ▶ If the actuator to be taught-in is within the actuating range for less than 60 s, it will not be activated and the most recently taught-in actuator will remain saved.

#### 9.2.1. Carrying out teach-in for a new actuator

1. Apply operating voltage to the safety switch.
  - ➔ The green LED flashes quickly (approx. 10 Hz).  
A self-test is performed during this time (approx. 3 s). After this, the LED flashes cyclically three times and signals that it is in standby state for teach-in.  
Standby state for teach-in remains active for approx. 3 minutes.
2. Move new actuator to the read head (observe distance  $< S_{a0}$ ).
  - ➔ Teach-in operation starts, green LED flashes (approx. 1 Hz). During the teach-in operation, the safety switch checks whether the actuator is a disabled actuator. Provided this is not the case, the teach-in operation is completed after approx. 60 seconds, and the green LED goes out. The new code has now been stored, and the old code is disabled.
3. To activate the new actuator code from the teach-in operation in the safety switch, the operating voltage to the safety switch must then be switched off for min. 3 seconds.

### 9.3. Functional check

After installation and any fault, the safety function must be fully checked. Proceed as follows:



**WARNING**

















Danger of fatal injury as a result of faults in installation and functional check.

- › Before carrying out the functional check, make sure that there are no persons in the danger zone.
- › Observe the valid accident prevention regulations.

1. Switch on operating voltage.
  - › The safety switch carries out a self-test.  
The green STATE LED flashes for 3 s at 10 Hz.  
The green STATE LED then flashes at regular intervals.
2. Close all guards.
  - › The machine must not start automatically.
  - › The green STATE LED illuminates continuously.
3. Enable operation in the control system.
4. Open the guard.
  - › The machine must switch off and it must not be possible to start it as long as the guard is open.
  - › The green STATE LED flashes at regular intervals.

Repeat steps 2-4 for each guard.

### 10. System status table

Operating mode	Actuator/door position	Safety outputs LA and LB	LED indicator Output		State
			STATE (green)	DIA (red)	
<b>Self-test</b>	X	off	 10 Hz (3 s)	○	Self-test after power-up
<b>Normal operation</b>	closed	on		○	Normal operation, door closed
	open	off	 1 x	○	Normal operation, door open
	open	off	 2 x	○	Normal operation, door open, no actuator taught
<b>Teach-in standby</b>	open	off	 3 x	○	Door open, device is ready for teach-in for another actuator (only short time after power-up)
<b>Setup</b>	closed	off	 1 Hz	○	Teach-in operation
	X	off	○	○	Positive acknowledgment after completion of teach-in operation
<b>Fault display</b>	X	off	 2 x		Overload (e.g. short circuit on a safety output)
	X	off	 3 x		Over-temperature
	X	off	 4 x		Output fault (e.g. fault on a switching element)
	X	off	 5 x		Internal fault (e.g. component fault, data error) or short circuit at the outputs
<b>Key to symbols</b>			○	LED not illuminated	
				LED illuminated	
			 10 Hz (8 s)	LED flashes for 8 seconds at 10 Hz	
			 3 x	LED flashes three times	
			X	Any state	



#### Important!

If you do not find the displayed device status in the system status table, this indicates an internal device fault. In this case, you should contact the manufacturer.

## 11. Technical data



### NOTICE

If a data sheet is included with the product, the information on the data sheet applies.

### 11.1. Technical data for safety switch CES-AH-C03-AE-LS

Parameter	Value			Unit
	min.	typ.	max.	
Housing material	PBT plastic			
Dimensions	40 x 40 x 168			mm
Weight	0.45			kg
Ambient temperature at $U_B = DC\ 24\ V$	-25	-	+70	°C
Storage temperature	-25	-	+70	
Degree of protection	IP65/IP67			
Safety class	III			
Degree of contamination	3			
Installation orientation	Any			
Connection	Connecting cable PUR 0.5 m with connectors AMP Superseal 1 x 3-pin / 1 x 4-pin			
Operating voltage $U_B$ (reverse polarity protected, regulated, residual ripple < 5%)	9	-	32	V DC
Current consumption	-	-	150	mA
External fuse (operating voltage, +LA and +LB)	0.25	-	10	A
Power supply for load $U(+LA)/U(+LB)$	$U_B$			
Power supply for load via PWM				
- Pulse frequency	-	-	1	kHz
- Mark/space ratio $T_{on}$	10	-	100	%
Safety outputs LA/LB	Semiconductor outputs, p-switching, short circuit-proof			
- Output voltage $U(LA)/U(LB)$ <sup>1)</sup>				
HIGH $U(LA)$	$U_B-1.5$	-	$U_B$	V DC
HIGH $U(LB)$				
LOW $U(LA)/U(LB)$	0		4	
Testing of the outputs				
Test pulse length	-	-	6	ms
- Test interval	10	-	-	s
Switching current per safety output	30	-	4,000	mA
Utilization category acc. to EN 60947-5-2	DC-13 24 V 4 A Caution: Outputs must be protected by a free-wheeling diode in the case of inductive loads.			
Start input START				
HIGH	8	-	$U_B$	V DC
LOW	0	-	2	
Rated insulation voltage $U_i$	-	-	75	V
Rated impulse withstand voltage $U_{imp}$	-	-	1.5	kV
Rated conditional short-circuit current	-	-	100	A
Resilience to vibration	Acc. to EN 60947-5-2			
Risk time	-	-	250	ms
Difference time between the two safety outputs	-	-	50	ms
Ready delay <sup>2)</sup>	-	-	3	s
Dwell time <sup>3)</sup>	0.5	-	-	s
Switching frequency	-	-	1	Hz
Repeat accuracy R acc. to EN IEC 60947-5-3	≤ 10			%
Mounting distance between 2 switches or 2 actuators	80	-	-	mm
LED displays	2 STATE (green) and DIA (red)			



### Reliability values acc. to EN ISO 13849-1

Category	3	
Performance Level (PL)	d	
PFH <sub>D</sub>	1.03 x 10 <sup>-7</sup> / h	
Mission time	20	years

1) Values at a switching current of 4 A without taking into account the cable lengths.

2) After the operating voltage is switched on, the semiconductor outputs are switched off during the ready delay.

3) The dwell time of an actuator inside and outside the actuating range must be at least 0.5 s to ensure reliable detection of internal faults in the evaluation unit (self-monitoring).

**11.2. Typical system times**

**Ready delay:** After switching on, the device carries out a self-test for 3 s. The system is ready for operation only after this time.

**Risk time according to EN 60947-5-3:** If an actuator moves outside the actuating range, the safety outputs LA and LB on the corresponding safety switch are deactivated at the latest after 250 ms.

**Difference time:** The safety outputs LA and LB switch with a slight time offset. They have the same signal state at the latest after a difference time of 50 ms.

**System times for reset after a fault and normal operation**

Secondary conditions: UB = 24 V  
 +LA permanently connected with UB  
 +LB switched by control system  
 Actuator moved

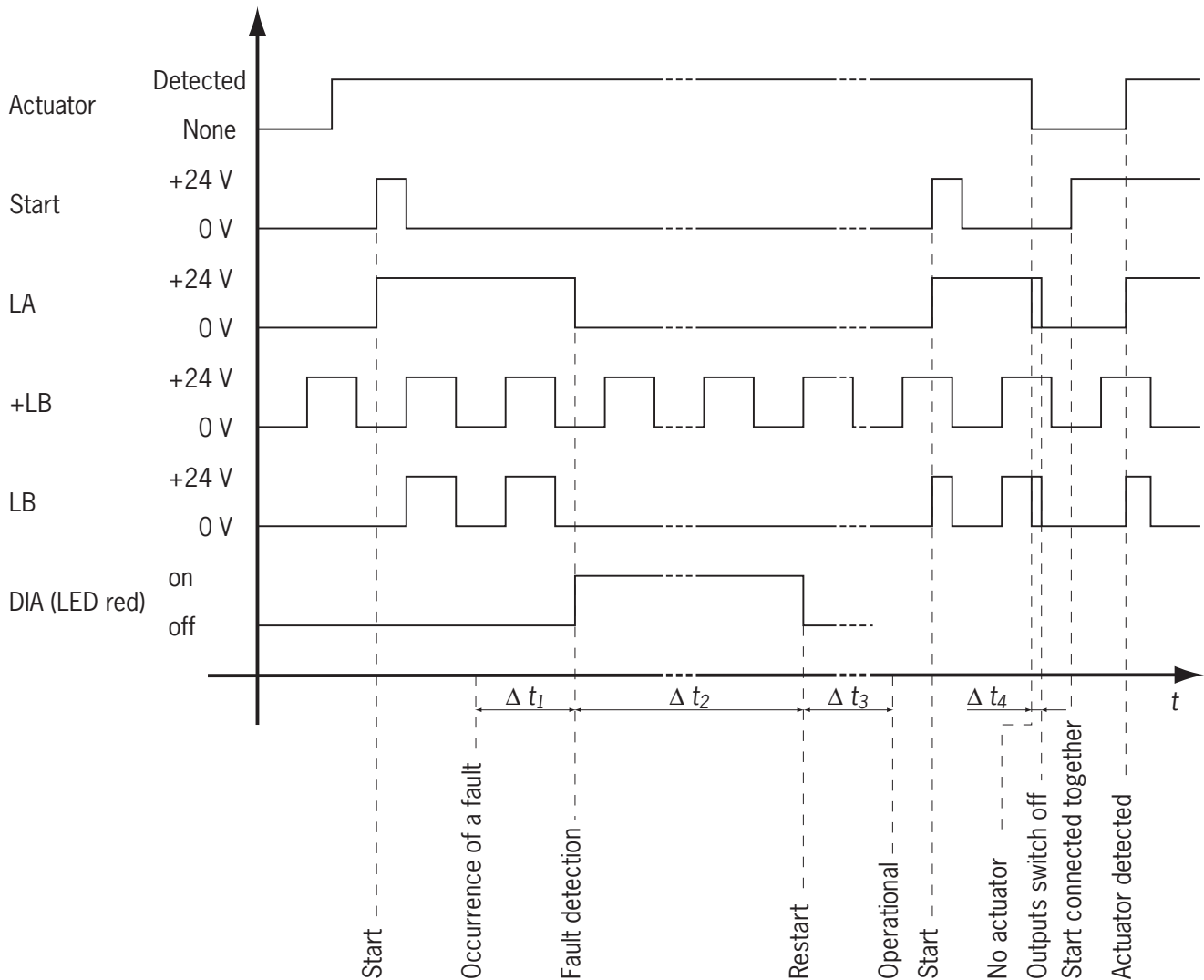

- $\Delta t_1$  = Fault detection time
- $\Delta t_2$  = Fault time (5 s; switch dwells in the fault state during this time)
- $\Delta t_3$  = Power-up time (3 s)
- $\Delta t_4$  = Risk time ( $\leq 250$  ms, time from *no actuator* to *outputs switch off*)

Figure 3: System times for individual switches

### 11.3. Dimension drawing and connector assignment

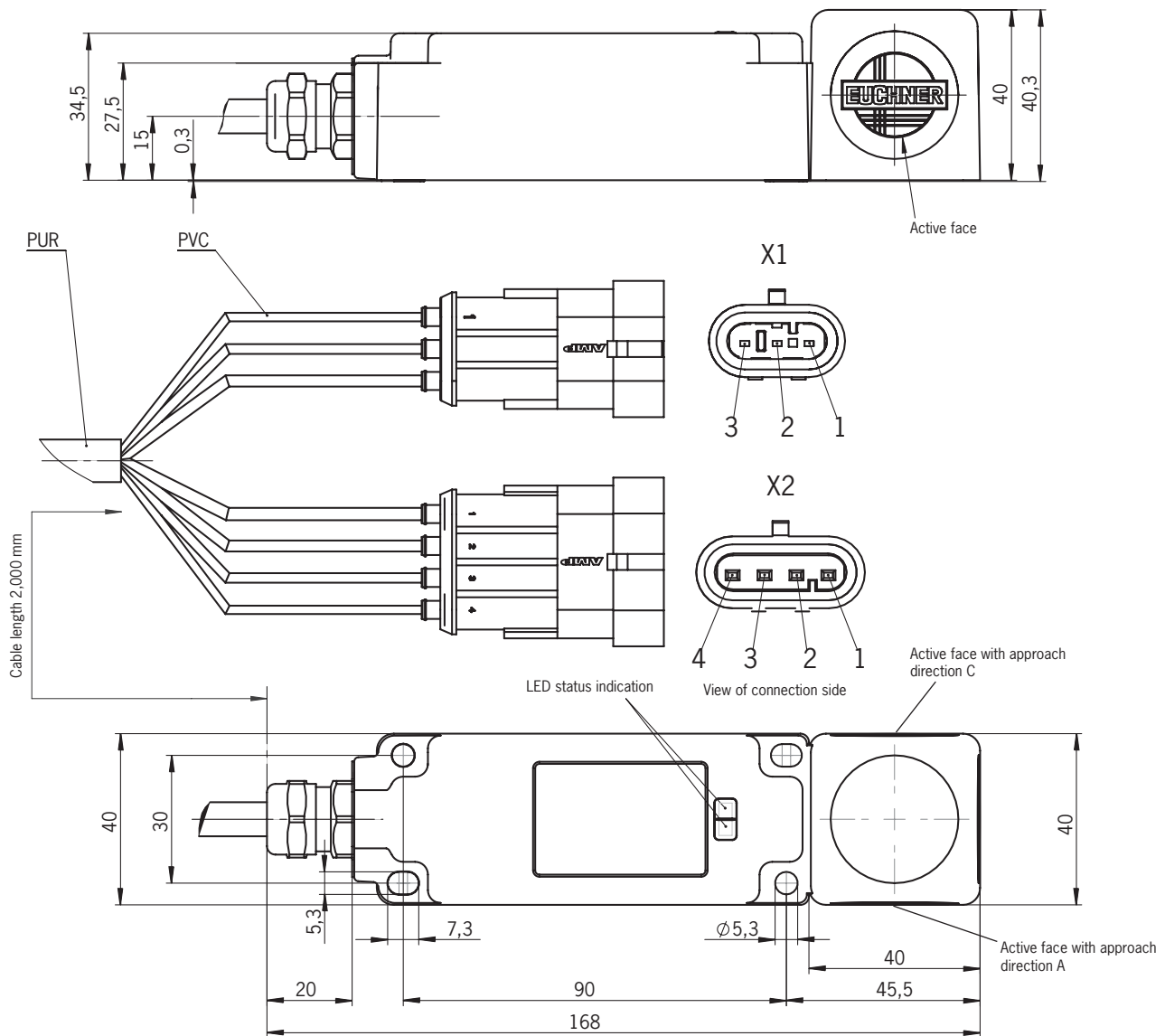

### 11.4. Technical data for actuator CES-A-BRN

Parameter	Value			Unit
	min.	typ.	max.	
Housing material	PPS			
Dimensions	80 x 40 x 15			mm
Weight	0.06			kg
Ambient temperature	- 25	-	+ 70	°C
Degree of protection	IP67			
Installation orientation	Active face opposite read head			
Power supply	Inductive via read head			

#### 11.4.1. Dimension drawing

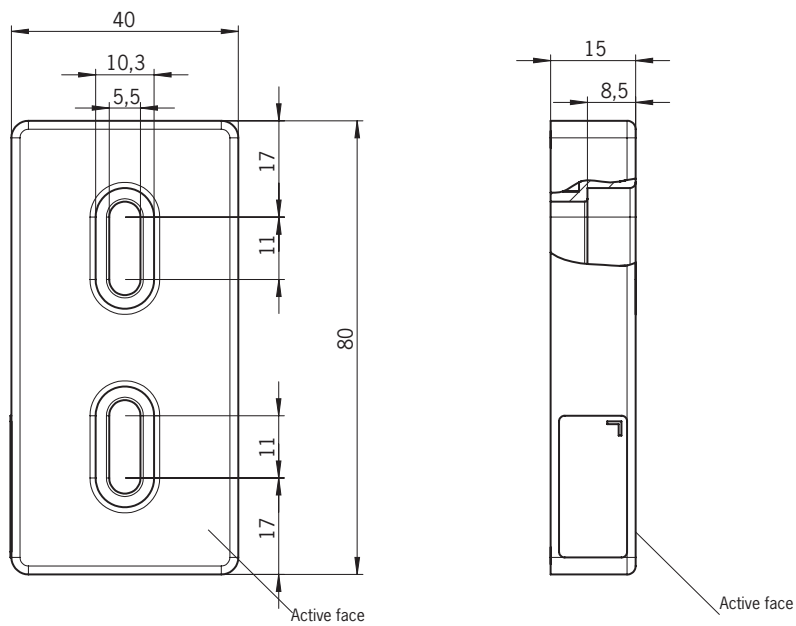

### 11.4.2. Operating distances

#### Actuating range for center offset $m = 0$

(only in combination with actuator CES-A-BRN)

Parameter	Value			Unit
	min.	typ.	max.	
Operating distance	-	32	-	mm
Assured operating distance $s_{ao}$ <sup>1)</sup>	27	-	-	
Switching hysteresis <sup>1)</sup>	-	3	-	
Assured release distance $s_{ar}$	-	-	75	

1) The values apply to surface installation of the actuator on steel.

#### Typical actuating range

(only in combination with actuator CES-A-BRN on surface mounting on steel)

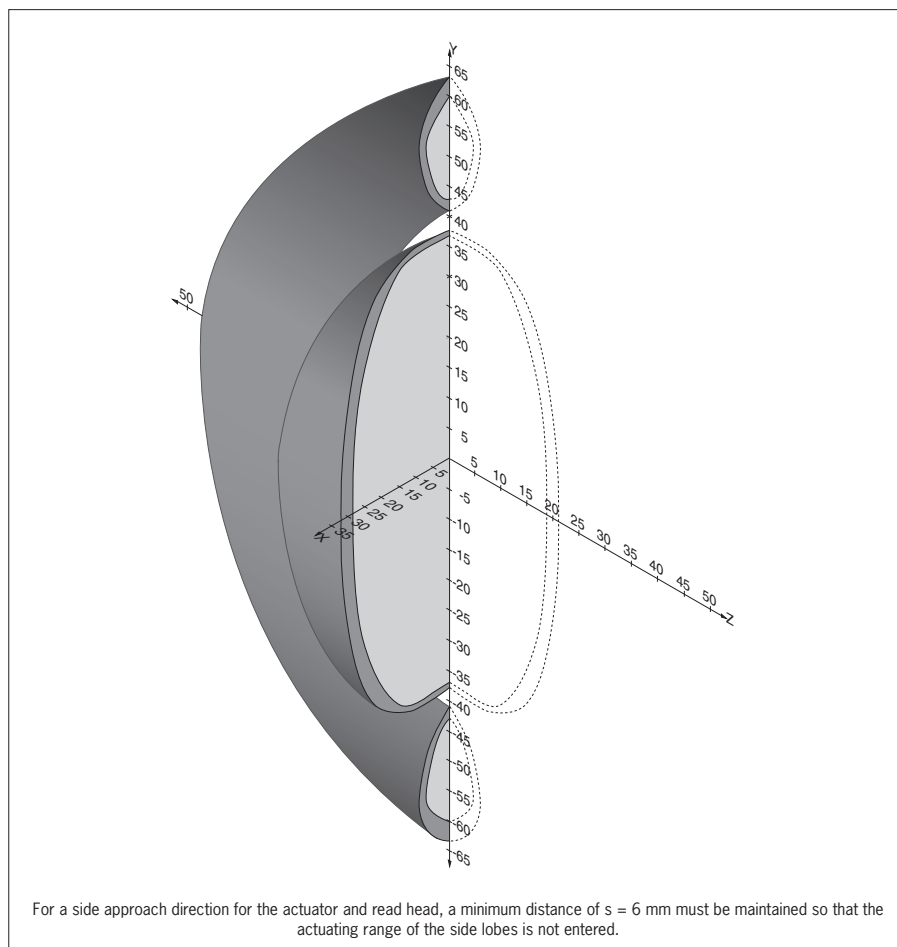

Figure 4: Typical actuating range

## 12. Ordering information and accessories



**Tip!**

Suitable accessories, e.g. cables or assembly material, can be found at [www.euchner.com](http://www.euchner.com). To order, enter the order number of your item in the search box and open the item view. Accessories that can be combined with the item are listed in *Accessories*.

## 13. Inspection and service



**WARNING**

Loss of the safety function because of damage to the device.

- › In case of damage, the entire device must be replaced.
- › Only accessories or spare parts that can be ordered from EUCHNER may be replaced.

Regular inspection of the following is necessary to ensure trouble-free long-term operation:

- › Check the switching function (see chapter 9.3. *Functional check on page 14*)
- › Check the secure mounting of the devices and the connections
- › Check for soiling

No servicing is required. Repairs to the device are only allowed to be made by the manufacturer.



**NOTICE**

The year of manufacture can be seen in the lower right corner of the type label. The current version number in the format (VX.X.X) can also be found on the device.

## 14. Service

If servicing is required, please contact:

EUCHNER GmbH + Co. KG  
Kohlhammerstraße 16  
70771 Leinfelden-Echterdingen  
Germany

**Service telephone:**

+49 711 7597-500

**E-mail:**

[support@euchner.de](mailto:support@euchner.de)

**Internet:**

[www.euchner.com](http://www.euchner.com)

### 15. Declaration of conformity



# EUCHNER

More than safety.

**EU-Konformitätserklärung**  
**EU declaration of conformity**  
**Déclaration UE de conformité**  
**Dichiarazione di conformità UE**  
**Declaración UE de conformidad**

Original DE  
Translation EN  
Traduction FR  
Traduzione IT  
Traducción ES

2127387-04-07/20

Die nachfolgend aufgeführten Produkte sind konform mit den Anforderungen der folgenden Richtlinien (falls zutreffend):  
The beneath listed products are in conformity with the requirements of the following directives (if applicable):  
Les produits mentionnés ci-dessous sont conformes aux exigences imposées par les directives suivantes (si valable)  
I prodotti sotto elencati sono conformi alle direttive sotto riportate (dove applicabili):  
Los productos listados a continuación son conforme a los requisitos de las siguientes directivas (si fueran aplicables):

I:	Maschinenrichtlinie Machinery directive Directive Machines Direttiva Macchine Directiva de máquinas	2006/42/EG 2006/42/EC 2006/42/CE 2006/42/CE 2006/42/CE
II:	RoHS Richtlinie RoHS directive Directive de RoHS Direttiva RoHS Directiva RoHS	2011/65/EU 2011/65/EU 2011/65/UE 2011/65/UE 2011/65/UE

Die Geräte sind für die Einhaltung der Schutzziele der EMV Richtlinie 2014/30/EU vorbereitet. Die abschließende Überprüfung der Konformität muss gemäß der Betriebsanleitung in der jeweiligen Anwendung vom Inverkehrbringer durchgeführt werden.  
The devices are prepared for compliance with the protective goals of EMC Directive 2014/30/EU. The distributing company is responsible for performing the final conformity check in accordance with the operating instructions in the respective application.  
Les appareils sont préparés pour respecter les objectifs de protection de la directive CEM 2014/30/UE. La vérification finale de la conformité doit être réalisée par le metteur sur le marché conformément au mode d'emploi dans l'application spécifique.  
I dispositivi sono predisposti per il conseguimento degli obiettivi di protezione della direttiva EMC 2014/30/UE. La verifica definitiva della conformità dovrà essere eseguita, secondo le istruzioni di impiego, nell'applicazione specifica, dal responsabile dell'immissione sul mercato.  
Los dispositivos están preparados para cumplir los fines de protección especificados en la Directiva CEM 2014/30/UE. La comprobación final de la conformidad debe llevarla a cabo la persona encargada de la comercialización, según el manual de instrucciones y en la aplicación correspondiente.

Folgende Normen sind angewandt: a: EN ISO 14119:2013  
Following standards are used: b: EN ISO 13849-1:2015  
Les normes suivantes sont appliquées: c: EN 60947-5-3:2013 without clause 8.6  
Vengono applicate le seguenti norme: d: EN IEC 63000:2018 (RoHS)  
Se utilizan los siguientes estándares:

Bezeichnung der Bauteile Description of components Description des composants Descrizione dei componenti Descripción de componentes	Type Type Type Tipo Tipo	Richtlinie Directives Directive Direttiva Directivas	Normen Standards Normes Norma Estándares	Prüfbericht Test report Rapport du test Rapporto di prova Informe de prueba
Sicherheitsschalter Safety Switches Interrupteurs de sécurité Finecorsa di sicurezza Interruptores de seguridad	CES-AH-C03-AE-LS-110370 CES-AH-C03-AE-LS-100255	I, II	a, b, c, d	Euchner QS PB 021/2010 Euchner QS PB 004/2016
Betätiger Actuator Actionneur Azionatore Actuador	CES-A-BRN-100251	I, II	a, b, c, d	Euchner QS PB 021/2010 Euchner QS PB 004/2016

Die alleinige Verantwortung für die Ausstellung dieser Konformitätserklärung trägt der Hersteller:  
This declaration of conformity is issued under the sole responsibility of the manufacturer:  
La présente déclaration de conformité est établie sous la seule responsabilité du fabricant:  
La presente dichiarazione di conformità è rilasciata sotto la responsabilità esclusiva del fabbricante:  
La presente declaración de conformidad se expide bajo la exclusiva responsabilidad del fabricante:

EUCHNER GmbH + Co. KG  
Kohlhammerstraße 16  
70771 Leinfelden-Echterdingen  
Germany

Leinfelden, July 2020  
EUCHNER GmbH + Co. KG  
Kohlhammerstraße 16  
70771 Leinfelden-Echterdingen  
Germany

i.A. Dipl.-Ing. Richard Holz  
Leiter Elektronik-Entwicklung  
Manager Electronic Development  
Responsable Développement Electronique  
Direttore Sviluppo Elettronica  
Director de desarrollo electrónico

i.A. Dipl.-Ing. (FH) Duc Binh Nguyen  
Dokumentationsbevollmächtigter  
Documentation manager  
Responsable documentation  
Responsabilità della documentazione  
Agente documenta

EUCHNER GmbH + Co. KG  
Kohlhammerstraße 16  
70771 Leinfelden-Echterdingen  
Germany  
info@euchner.de  
www.euchner.com

Edition:  
2105267-10-08/20  
Title:  
Operating Instructions Non-Contact Safety Switch  
CES-AH-C03-AE-LS  
(Translation of the original operating instructions)  
Copyright:  
© EUCHNER GmbH + Co. KG, 08/2020

Subject to technical modifications; no responsibility is accepted for the accuracy of this information.