



Scope

These operating instructions are valid for all NZ.VZ...AS. These operating instructions, the document *Safety information* and any available data sheet form the complete user information for your device.

Important!

Make sure to use the operating instructions valid for your product version. The version numbers can be found on the type label of your product. Please contact the EUCHNER service team if you have any questions.

Safety switch type label

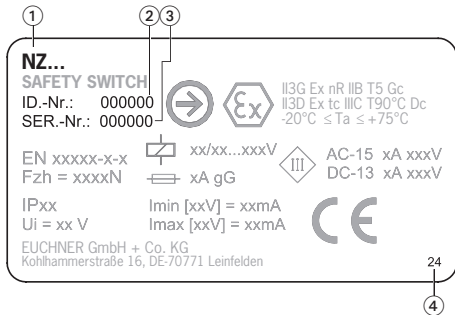

- ① Item designation
- ② Item number
- ③ Serial number
- ④ Year of manufacture

Supplementary documents

The overall documentation for this device consists of the following documents:

Document title (document number)	Contents	
Safety information (2525460)	Basic safety information	
Operating instructions (2090766)	(this document)	
Declaration of conformity	Declaration of conformity	
Any additions to the operating instructions	Take any associated additions to the operating instructions or data sheets into account.	

Important!

Always read all documents to gain a complete overview of safe installation, setup and use of the device. The documents can be downloaded from www.euchner.com. For this purpose, enter the doc. no. or the order number for the device in the search box.

Correct use

Safety switches series NZ.VZ...AS are operated as a slave on the safety bus AS-Interface Safety at Work and function as interlocking devices without guard locking (type 2). The actuator has a low coding level. In combination with a movable guard and the machine control, this safety component prevents dangerous machine functions from occurring while the guard is open. A stop command is triggered if the guard is opened during the dangerous machine function.

This means:

- ▶ Starting commands that cause a dangerous machine function must become active only when the guard is closed.
- ▶ Opening the guard triggers a stop command.
- ▶ Closing a guard must not cause automatic starting of a dangerous machine function. A separate start command must be issued. For exceptions, refer to EN ISO 12100 or relevant C-standards.

Before the device is used, a risk assessment must be performed on the machine, e.g. in accordance with the following standards:

- ▶ EN ISO 13849-1
- ▶ EN ISO 12100
- ▶ EN IEC 62061

Correct use includes observing the relevant requirements for installation and operation, particularly based on the following standards:

- ▶ EN ISO 13849-1
- ▶ EN ISO 14119
- ▶ EN IEC 60204-1

Important!

- ▶ The user is responsible for the proper integration of the device into a safe overall system. For this purpose, the overall system must be validated, e.g. in accordance with EN ISO 13849-1.
- ▶ If the simplified method according to section 6.2.3 of EN ISO 13849-1:2023 is used for determining the Performance Level (PL), the PL might be reduced if several devices are connected in series.
- ▶ If a data sheet is included with the product, the information on the data sheet applies in case of discrepancies with the operating instructions.

Safety precautions

⚠ WARNING

Danger to life due to improper installation or due to bypassing (tampering). Safety components fulfill a personnel protection function.

- ▶ Safety components must not be bypassed, turned away, removed or otherwise rendered ineffective. On this topic pay attention in particular to the measures for reducing the possibility of bypassing according to EN ISO 14119:2025, section 8.
- ▶ The switching operation must be activated only by actuators designated for this purpose.
- ▶ Prevent bypassing by means of replacement actuators. For this purpose, restrict access to actuators and to keys for releases, for example.
- ▶ Mounting, electrical connection and setup only by authorized personnel possessing special knowledge about handling safety components.

Function

The safety switch monitors the position of movable guards. The switching contacts are actuated on the insertion/removal of the actuator.

When the guard is closed, each NZ.VZ...AS transmits a switch-specific, unique safety code sequence with 8 x 4 bits via the AS-Interface bus. This code sequence is evaluated by an AS-Interface safety monitor.

The first positively driven contact is represented by the AS-Interface input bits D0 and D1, while the second positively driven contact is represented by D2 and D3.

The safety switch must be correspondingly configured in the AS-Interface safety monitor (refer to the operating instructions of the AS-Interface safety monitor used and the status table).

Selection of the actuator

NOTICE

- ▶ Damage to the device due to unsuitable actuator. Make sure to select the correct actuator.
- ▶ Additionally pay attention to the door radius and the mounting options (see Fig. 4).

Mounting

NOTICE

- Device damage due to improper mounting and unsuitable ambient conditions.
- ▶ Safety switches and actuators must not be used as an end stop.
- ▶ Observe EN ISO 14119:2025, sections 6.2 and 6.3, for information about mounting the safety switch and the actuator.
- ▶ Observe EN ISO 14119:2025, section 8, for information about reducing the possibilities for bypassing an interlocking device.
- ▶ Protect the switch head against damage, as well as penetrating foreign objects such as swarf, sand and blasting shot, etc.
- ▶ The specified IP degree of protection is applicable only if the housing screws, cable entries and plug connectors are properly tightened. Observe the tightening torques.

Changing the actuating direction

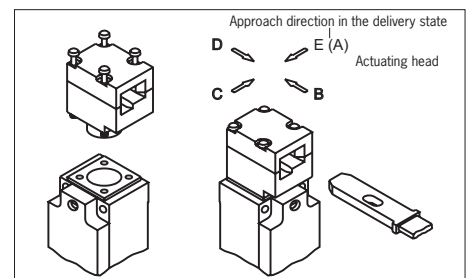

Fig. 1: Changing the actuating direction

1. Remove the screws from the actuating head.
2. Set the required direction.
3. Tighten the screws with a torque of 1.2 Nm.

Electrical connection

The safety switch is connected to the bus system with a 4-pin connecting cable with M12 plug connector via a passive AS-Interface distribution box with a yellow and black AS-Interface cable.

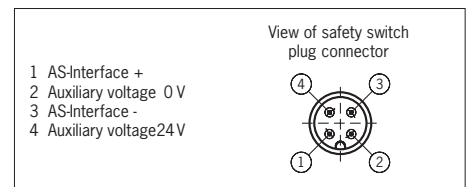

Fig. 2: Terminal assignment of M12 plug connector

The following information applies to devices with plug connector:

- ▶ Check that the plug connector is sealed.

Setup

Setting the AS-Interface address

The address can be set prior to or after mounting. The AS-Interface address of the safety switch is set using an AS-Interface programming device. Addresses 1 to 31 are valid.

The unit is programmed by connecting the programming device to the M12 plug connector of the safety switch with a programming cable.

Address 0 is the default setting on delivery (the AS-Interface *Fault* LED is lit during operation).

Configuration in the AS-Interface safety monitor

(see operating instructions for the AS-Interface safety monitor and status table)

The safety switch is configured in the AS-Interface safety monitor with the AS-Interface address set as follows, for example:

- ▶ Dual-channel dependent
- ▶ Synchronization time: typ. 3 s

It may be necessary to set the synchronization time to higher values. This depends on the application and the approach speed of the actuator.

- ▶ With start-up test (corresponding to risk analysis) In this operating mode, the guard must be opened each time prior to restarting in order to perform the start-up test.

LED displays

The AS-Interface bus status is indicated by two LEDs (Power, Fault).

Function test

⚠ WARNING

Fatal injury due to faults during the function test.

- ▶ Before carrying out the function test, make sure that there are no persons in the danger area.
- ▶ Observe the valid accident prevention regulations.

Check the device for correct function after installation and after every fault.

Proceed as follows:

Mechanical function test

The actuator must slide easily into the actuating head. Close the guard several times to check the function.

Electrical function test

1. Switch on operating voltage.
2. Close all guards.
 - ➔ The machine must not start automatically.
3. Start the machine function.
4. Open the guard.
 - ➔ The machine must switch off and it must not be possible to start it as long as the guard is open.

Repeat steps 2 - 4 for each guard.

Inspection and service

⚠ WARNING

Danger of severe injuries due to the loss of the safety function.

- ▶ If damage or wear is found, the complete switch and actuator assembly must be replaced. Replacement of individual parts or assemblies is not permitted.
- ▶ Check the device for proper function at regular intervals and after every fault. For information about possible time intervals, refer to EN ISO 14119:2025, section 9.2.1.

Inspection of the following is necessary to ensure trouble-free long-term operation:

- ▶ Correct switching function
- ▶ Secure mounting of all components
- ▶ Damage, heavy contamination, dirt and wear
- ▶ Sealing of cable entry
- ▶ Loose cable connections or plug connectors.

Exclusion of liability and warranty

In case of failure to comply with the conditions for correct use stated above, or if the safety regulations are not followed, or if any servicing is not performed as required, liability will be excluded and the warranty void.

Notes about UL

- ▶ This device is intended to be used with a Class 2 power source in accordance with UL1310.

As an alternative an LV/C (Limited Voltage/Current) power source with the following properties can be used:

This device shall be used with a suitable isolating source in conjunction with a fuse in accordance with UL248. The fuse shall be rated max. 3 A and be installed in the max. 33.3 V DC power supply to the device in order to limit the available current to comply with the UL requirements. Please note possibly lower connection ratings for your device (refer to the technical data).

- ▶ For use and application in accordance with UL requirements¹⁾, a connecting cable listed under the UL category code CYJV/7 must be used.

1) Note on the scope of the UL approval: The devices have been tested as per the requirements of UL508 and CSA/C22.2 no. 14 (protection against electric shock and fire).

Declaration of conformity

The product complies with the requirements according to

- ▶ Machinery Directive 2006/42/EC (until January 19, 2027)
- ▶ Machinery Regulation (EU) 2023/1230 (from January 20, 2027)

The EU declaration of conformity can be found at www.euchner.com. Enter the order number of your device in the search box. The document is available under *Downloads*.

Service

If servicing is required, please contact:

EUCHNER GmbH + Co. KG
Kohlhammerstraße 16
70771 Leinfelden-Echterdingen

Service telephone:
+49 711 7597-500

E-mail:
support@euchner.de

Internet:
www.euchner.com

Technical data

Parameter	Value
Housing material	Die-cast alloy anodized
Degree of protection	IP67, mating connector inserted
Mechanical life	2 x 10 ⁶ operating cycles
Ambient temperature	-20 ... +55 °C
Degree of contamination	3 (industrial)
Installation position	Any
Approach speed, max.	20 m/min
Extraction force	35 N
Retention force	10 N
Actuating force, max.,	35 N
Actuation frequency	7,000/h
Switching principle	2 positively driven contacts, slow-action switching contact
Connection	Plug connector M12, 4-pin
Weight	Approx. 0.35 kg
AS-Interface data acc. to AS-Interface specification 2.1	EA code: 7 ID code: B
Operating voltage, AS-Interface	DC 22.5 ... 31.6 V
Total current consumption, max.	45 mA
Valid AS-Interface addresses	1 - 31
AS-Interface inputs	Acc. to AS-Interface Safety at Work
Positively driven contact 1	D0, D1
Positively driven contact 2	D2, D3
AS-Interface outputs	
D1	Red LED, 1 = LED on
D2	Green LED, 1 = LED on
AS-Interface Power LED	Green, AS-Interface Power on
AS-Interface Fault LED	Red, offline phase or address "0"
Characteristics acc. to EN ISO 13849-1	
Monitoring of the guard position	
B _{10D} at DC-13 100 mA/24 V	4.5 x 10 ⁶

Status table

Programming	State	D0, D1	D2, D3	Monitor diagnostics
2-channel dependent Synchronization time 3 s	Guard closed	Code sequence		Green If start-up test selected: yellow flashing on start-up
	Intermediate state during opening or closing of the guard. Switch S1 (internal) open	Half-sequence	00	On opening: yellow flashing On closing: red After expiration of the synchronization time: yellow flashing
	Intermediate state during opening or closing of the guard. Switch S2 (internal) open	00	Half-sequence	
	Guard open	00	00	Red
	Address 0 or communication disrupted	-		Gray



Subject to technical modifications; no responsibility is accepted for the accuracy of this information. © EUCHNER GmbH + Co. KG 2090766-09-07/25 (translation of the original operating instructions)

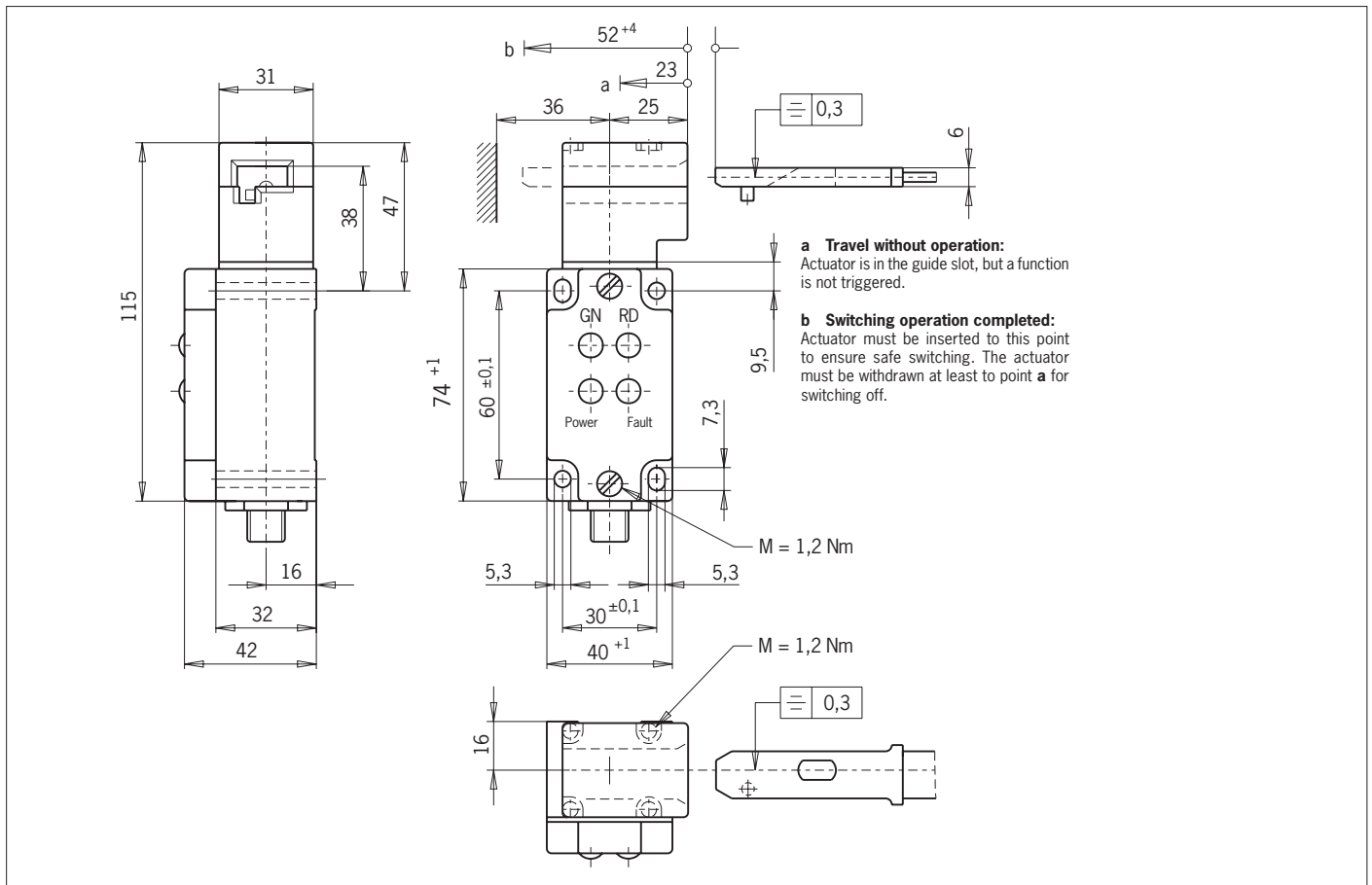

Fig. 3: Dimension drawing NZ.VZ...AS

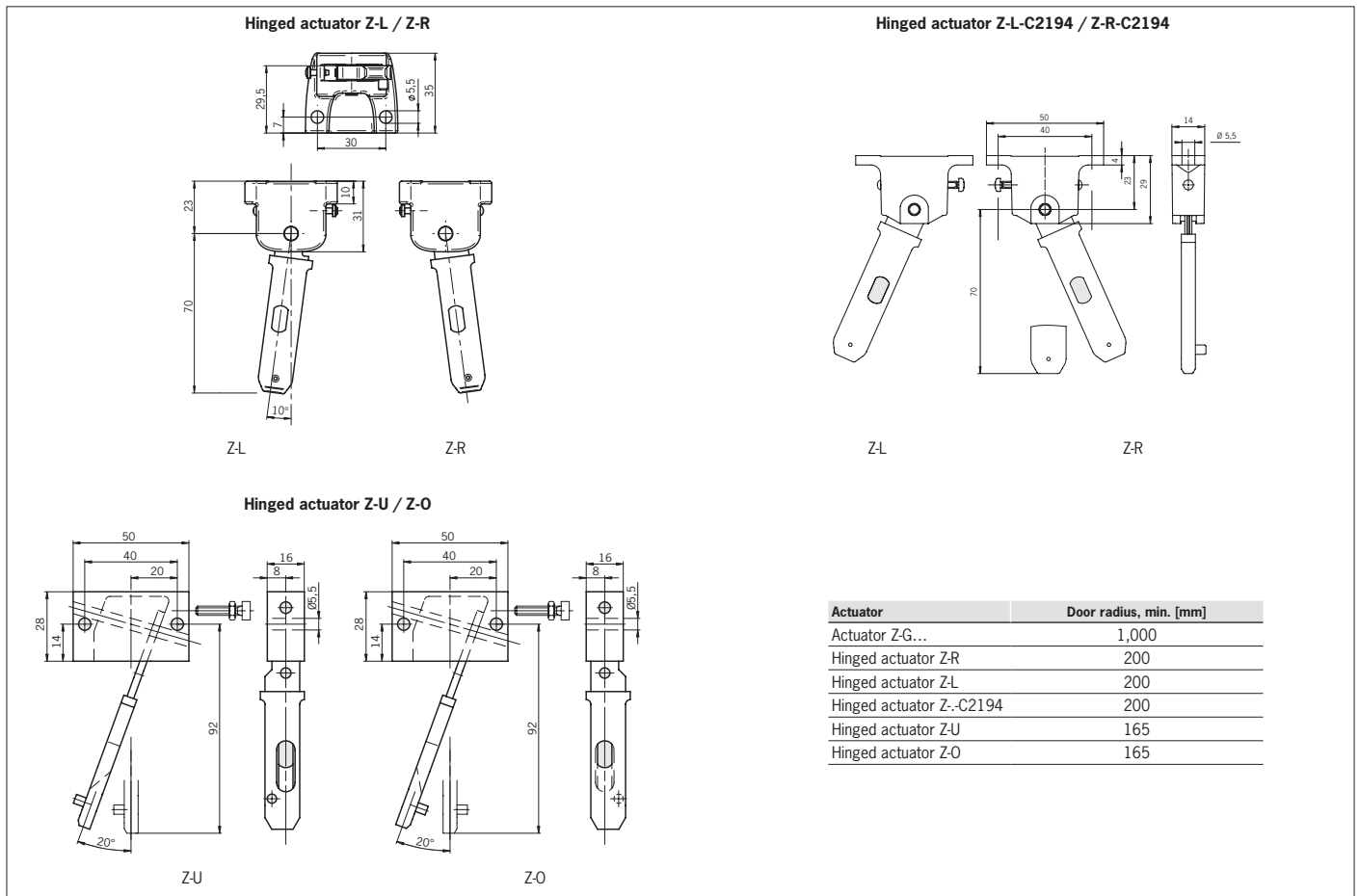

Fig. 4: Minimum door radii