

EUCHNER

Operating Instructions

Transponder-Coded Safety Switch with Guard Locking for Process Protection
CTM-I2-AS2B Unicode/Multicode

EN

Contents

1.	About this document	4
1.1.	Scope.....	4
1.2.	Target group	4
1.3.	Key to symbols.....	4
1.4.	Supplementary documents	4
2.	Correct use	5
3.	Description of the safety function	6
4.	Exclusion of liability and warranty	6
5.	General safety precautions	6
6.	Function	7
6.1.	Guard locking on version CTM-I2	7
6.2.	Switching states	8
7.	Manual release	9
7.1.	Auxiliary release.....	9
8.	Mounting	10
9.	Electrical connection	11
9.1.	Notes about c(UL)us.....	11
9.2.	Setting the AS-Interface address	12
9.3.	Configuration in the AS-Interface safety monitor	12
9.3.1.	Dual-channel dependent.....	12
9.3.2.	Dual-channel positively driven.....	12
9.4.	AS-Interface status messages.....	12
9.5.	Safety in case of faults.....	12
9.6.	Connection of guard locking control	13
9.6.1.	Guard locking control by means of switching the auxiliary voltage	13
9.6.2.	Guard locking control via ASi bit DO.....	13
10.	Setup	14
10.1.	LED displays	14
10.2.	Teaching-in actuator (only for unicode evaluation)	14
10.3.	Functional check.....	15
10.3.1.	Mechanical function test	15
10.3.2.	Electrical function test.....	15
11.	System status table	16

12.	Technical data	17
12.1.	Technical data for safety switch CTM-I2-AS2B	17
12.1.1.	Typical system times.....	18
12.2.	Dimension drawing for safety switch CTM... ..	19
12.3.	Technical data for actuator A-B-A1-A1-.....	20
12.3.1.	Dimension drawing for actuator A-B-A1-A1-... ..	20
12.4.	Technical data for actuator A-B-A5-A1-.....	21
12.4.1.	Dimension drawing for actuator A-B-A5-A1-... ..	21
13.	Ordering information and accessories	22
14.	Inspection and service	22
15.	Service	22
16.	Declaration of conformity	22

1. About this document

1.1. Scope





These operating instructions apply to all CTM-I2-AS2B... of version V1.1.X. These operating instructions, the document *Safety information* and any available data sheet form the complete user information for your device.

	<p>Important!</p> <p>Make sure to use the operating instructions valid for your product version. Please contact the EUCHNER support team if you have any questions.</p>
---	--

1.2. Target group





Design engineers and installation planners for safety devices on machines, as well as setup and servicing staff possessing special expertise in handling safety components.

1.3. Key to symbols

Symbol/depiction	Meaning
	Printed document
	Document is available for download at www.euchner.com
 DANGER WARNING CAUTION	<p>Safety precautions</p> <p>Danger of death or severe injuries</p> <p>Warning about possible injuries</p> <p>Caution slight injuries possible</p>
 NOTICE Important!	<p>Notice about possible device damage</p> <p>Important information</p>
Tip	Useful information

1.4. Supplementary documents

The overall documentation for this device consists of the following documents:

Document title (document number)	Contents	
Safety information (2525460)	Basic safety information	
Operating instructions (MAN20001648)	(this document)	
Declaration of conformity	Declaration of conformity	
Possibly available data sheet	Item-specific information about deviations or additions	 

	<p>Important!</p> <p>Always read all documents to gain a complete overview of safe installation, setup and use of the device. The documents can be downloaded from www.euchner.com. For this purpose enter the doc. no. in the search box.</p>
---	--

2. Correct use

Safety switches series CTM-...-AS.. are operated as slaves on the safety bus AS-Interface Safety at Work and function as interlocking devices with Guard Locking for Process Protection (type 4) without guard locking monitoring. The device complies with the requirements according to EN 60947-5-3. Devices with unicode evaluation possess a high coding level, devices with multicode evaluation possess a low coding level.

In combination with a movable guard and the machine control, this safety component prevents dangerous machine functions from occurring while the guard is open. A stop command is triggered if the guard is opened during the dangerous machine function.

This means:

- › Starting commands that cause a dangerous machine function must become active only when the guard is closed.
- › Opening the guard triggers a stop command.
- › Closing a guard must not cause automatic starting of a dangerous machine function. A separate start command must be issued. For exceptions, refer to EN ISO 12100 or relevant C-standards.

Before the device is used, a risk assessment must be performed on the machine, e.g. in accordance with the following standards:

- › EN ISO 13849-1
- › EN ISO 12100
- › IEC 62061

Correct use includes observing the relevant requirements for installation and operation, particularly based on the following standards:

- › EN ISO 13849-1
- › EN ISO 14119
- › EN 60204-1

The safety switch is allowed to be operated only in conjunction with the intended EUCHNER actuator and the related connection components from EUCHNER. If different actuators or other connection components are used, EUCHNER provides no warranty for safe function.



Important!

- › The user is responsible for the proper integration of the device into a safe overall system. For this purpose, the overall system must be validated, e.g. in accordance with EN ISO 13849-1.
- › It is only allowed to use components that are permissible in accordance with the table below.

Table 1: Possible combinations for CTM components

Safety switch	Actuator	
	A-B-A1-...	A-B-A5-...
CTM-... Unicode/Multicode		
Key to symbols		Combination possible, guard locking for process protection

3. Description of the safety function

Devices from this series feature the following safety functions:

Monitoring of the position of the guard (interlocking device according to EN ISO 14119)

- › Safety function (see chapter 6.2. *Switching states on page 8*):
 - When the guard is open, no valid code sequence is sent (monitoring of the door position).
- › Safety characteristics: category, Performance Level, PFH_D (see chapter 12. *Technical data on page 17*).

4. Exclusion of liability and warranty

In case of failure to comply with the conditions for correct use stated above, or if the safety regulations are not followed, or if any servicing is not performed as required, liability will be excluded and the warranty void.

5. General safety precautions

Safety switches fulfill personnel protection functions. Incorrect installation or tampering can lead to fatal injuries to personnel.

Check the safe function of the guard particularly

- › after any setup work
- › after the replacement of a system component
- › after an extended period without use
- › after every fault

Independent of these checks, the safe function of the guard should be checked at suitable intervals as part of the maintenance schedule.



WARNING

Danger to life due to improper installation or due to bypassing (tampering). Safety components fulfill a personnel protection function.

- › Safety components must not be bypassed, turned away, removed or otherwise rendered ineffective. On this topic pay attention in particular to the measures for reducing the possibility of bypassing according to EN ISO 14119:2013, section 7.
- › The switching operation must be triggered only by actuators designated for this purpose.
- › Prevent bypassing by means of replacement actuators (only for multicode evaluation). For this purpose, restrict access to actuators and to keys for releases, for example.
- › Damaged actuators can lead to limited prevention of inadvertent locking position (faulty closure protection) when the machine is switched on. The guard locking function can no longer be ensured if an actuator is broken. Opening the door will cause the zero sequence to be sent. Regularly check the actuator for mechanical damage.
- › Mounting, electrical connection and setup only by authorized personnel possessing the following knowledge:
 - specialist knowledge in handling safety components
 - knowledge about the applicable EMC regulations
 - knowledge about the applicable regulations on operational safety and accident prevention



Important!

Prior to use, read the operating instructions and keep these in a safe place. Ensure the operating instructions are always available during mounting, setup and servicing. You can download the operating instructions from www.euchner.com.

6. Function

The device monitors the position of movable guards.

The system consists of the following components: coded actuator (transponder) and switch.

Whether the device learns the complete actuator code (unicode) or not (multicode) depends on the respective version.

- › **Devices with unicode evaluation:** The actuator must be assigned to the safety switch by a teach-in operation so that it is detected by the system. This unambiguous assignment ensures a particularly high level of protection against tampering. The system thus possesses a high coding level.
- › **Devices with multicode evaluation:** Unlike systems with unicode evaluation, on multicode devices a specific code is not requested but instead it is only checked whether the actuator is of a type that can be detected by the system (multicode detection). There is no exact comparison of the actuator code with the taught-in code in the safety switch (unicode evaluation). The system possesses a low coding level.

When the guard is closed, the actuator is moved into the safety switch. Guard locking can be activated only when the actuator is located in the switch (prevention of inadvertent locking position (faulty closure protection)). When the operating distances are reached, power is supplied to the actuator by the switch and data transfer begins.

If the guard is closed and the code is permissible, each CTM-AS transmits a switch-specific, unique safety code sequence with 8 x 4 bits via the AS-Interface bus.

The zero sequence is transmitted via the AS-Interface bus when the guard is opened.

In the event of a fault in the safety switch, the zero sequence is transmitted via the AS-Interface bus and the LOCK/DIA LED illuminates red. The occurrence of faults is detected at the latest on the next demand to close the safety outputs (e.g. on starting).

6.1. Guard locking on version CTM-I2

(guard locking actuated by power-ON and released by spring force)

Activating guard locking: close the guard, apply auxiliary power to the solenoid and set AS-Interface output bit D0.

Releasing guard locking: no auxiliary power at the solenoid and/or clear AS-Interface output bit D0.

The magnetically actuated guard locking operates in accordance with the open-circuit current principle. If the solenoid is not controlled (D0=0) or if auxiliary power is switched off, guard locking is released and the guard can be opened directly!

If the solenoid is controlled via the ASi bus (D0=1) and auxiliary power is applied to the solenoid, guard locking is activated and the guard is locked.

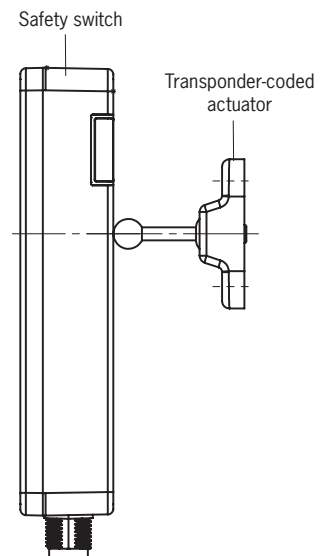

6.2. Switching states

Guard closed and locked

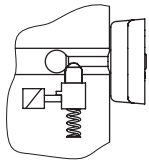

Guard closed and not locked

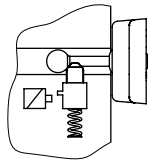

Guard being opened

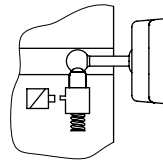

Guard open

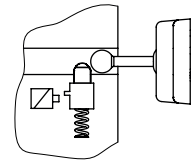

Programming	State	D0, D1	D2, D3	Monitor diagnostics
2-channel dependent Synchronization time ≥ 100 ms / 2-channel positively driven	Guard closed	Code sequence		Green If start-up test selected: yellow flashing on start-up
	Intermediate state during opening or closing of the guard. Switch S1 (internal) open	Half-sequence	00	On opening: yellow flashing On closing: red After expiration of the synchronization time: yellow flashing
	Intermediate state during opening or closing of the guard. Switch S2 (internal) open	00	Half-sequence	
	Guard open	00	00	Red
	Address 0 or communication disrupted	-		Gray

7. Manual release



Important!

- › All release functions latch when the device is electrically isolated.
- › Guard locking remains released when the release function is reset.

Some situations require the guard locking to be released manually (e.g. malfunctions or an emergency). A function test should be performed after release.

Further information on this topic can be found in the standard EN ISO 14119:2013, section 5.7.5.1. The device can feature the following release functions:

7.1. Auxiliary release

In the event of malfunctions, the guard locking can be released with the auxiliary release irrespective of the state of the solenoid.



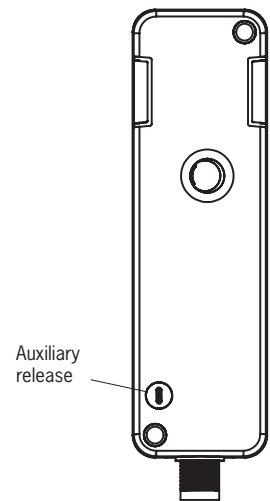

Important!

- › The actuator must not be under tensile stress during manual release.
- › To prevent tampering, the auxiliary release must be sealed with sealing lacquer, for example, before the switch is set up.
- › Loss of the release function due to mounting errors or damage during mounting.
- › Check the release function every time after mounting.
- › After manual release, the solenoid must be energized briefly to re-establish guard locking.
- › The auxiliary release must be reset at the control system level, e.g. by means of a plausibility check (status of the safety outputs does not match the guard locking control signal). See EN ISO 14119:2013, sec. 5.7.5.4.
- › The auxiliary release is not a safety function.
- › The correct function must be checked at regular intervals.
- › Observe the notes on any available data sheets.



Actuating auxiliary release

1. Remove seal label or make a hole.
2. Using a screwdriver, turn the auxiliary release to  in the direction of the arrow.
 - ➔ Guard locking is released.
 - ➔ The zero sequence is sent via the ASi bus.
3. Using a screwdriver, turn the auxiliary release to  in the opposite direction to the arrow to reset.
4. Seal with sealing lacquer.
5. Close the guard.
6. Carry out reset, see chapter 11. *System status table on page 16.*
 - ➔ The device operates normally again.
7. Check correct function of the device.

8. Mounting



CAUTION

Safety switches must not be bypassed (bridging of contacts), turned away, removed or otherwise rendered ineffective.

- › Observe EN ISO 14119:2013, section 7, for information about reducing the possibilities for bypassing an interlocking device.



NOTICE

Risk of damage to equipment and malfunctions as a result of incorrect installation.

- › Safety switches and actuators must not be used as an end stop.
- › Observe EN ISO 14119:2013, sections 5.2 and 5.3, for information about mounting the safety switch and the actuator.
- › Protect the switch against damage, as well as against penetrating foreign objects such as swarf, sand and blasting shot, etc.
- › Observe the min. door radii (see chapter 12.2. *Dimension drawing for safety switch CTM... on page 19*).
- › Observe the maximum permissible angle between switch and actuator (max. 5°).
- › Fasten the actuator using non-removable safety screws.
- › Observe the tightening torque for mounting the switch and the actuator (max. 2.9 Nm).
- › The rear side of the switch and the actuator's plate must lie fully on the mounting surface.
- › When installing the switch in a concealed position, bear in mind that the active face of the read head must be kept clear (see chapter 12.2. *Dimension drawing for safety switch CTM... on page 19*).
- › Actuator and safety switch must be mounted such that the actuator is perpendicularly and completely inserted into the switch when the guard is closed. The guard locking function is not assured if mounting is incorrect.
- › The auxiliary release must be sealed before setup, e.g. with sealing lacquer.
- › When mounting several safety switches, observe the stipulated minimum distance to avoid mutual interference.

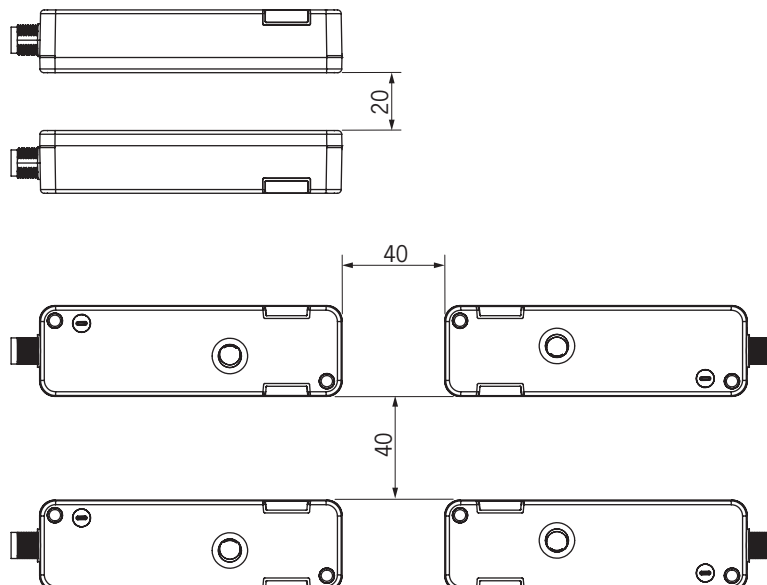

9. Electrical connection





<ol style="list-style-type: none"> 1 AS-Interface + 2 Auxiliary voltage, 0 V 3 AS-Interface - 4 Auxiliary voltage, 24 V 	<p>View of safety switch plug connector</p> 
---	--

Fig. 1: Terminal assignment, AS-Interface M12 plug connector

	<p>CAUTION</p> <p>Risk of damage to equipment or malfunctions as a result of incorrect connection.</p> <ul style="list-style-type: none"> ▸ Power devices which are a powerful source of interference must be installed in a separate location away from the input and output circuits for signal processing. The cable routing for safety circuits should be as far away as possible from the cables of the power circuits. ▸ To avoid EMC interference, the physical environmental and operating conditions at the installation site of the device must comply with the requirements according to the standard EN 60204-1:2006, section 4.4.2 (EMC). ▸ Pay attention to any interference fields from devices such as frequency converters or induction heating systems. Observe the EMC instructions in the manuals from the respective manufacturer. ▸ To ensure the degree of protection IP67 is achieved, the mating connector must be tightened with 0.3 Nm. This value must not be exceeded, however.
	<p>Important!</p> <p>If the device does not appear to function when the operating voltage is applied (e.g. the green STATE LED does not flash), the safety switch must be returned unopened to EUCHNER.</p>

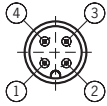
9.1. Notes about

	<p>Important!</p> <ul style="list-style-type: none"> ▸ This device is intended to be used with a Class 2 power source in accordance with UL1310. As an alternative an LV/C (Limited Voltage/Current) power source with the following properties can be used: <ul style="list-style-type: none"> - This device shall be used with a suitable isolating source in conjunction with a fuse in accordance with UL248. The fuse shall be rated max. 3.3 A and be installed in the max. 30 V DC power supply to the device in order to limit the available current to comply with the UL requirements. Please note possibly lower connection ratings for your device (refer to the technical data). ▸ For use and application as per the requirements of UL ¹⁾ a connecting cable listed under the UL category code CYJV/7, min. 24 AWG, min. 80 °C, must be used. <p><small>1) Note on the scope of the UL approval: the devices have been tested as per the requirements of UL508 and CSA/C22.2 no. 14 (protection against electric shock and fire).</small></p>
---	--

9.2. Setting the AS-Interface address

The address can be set prior to or after mounting.

The AS-Interface address of the safety switch is set using an AS-Interface programming device. Addresses 1 to 31 are valid. The unit is programmed by connecting the programming device to the M12 plug connector of the safety switch with a programming cable.

Address 0 is the default setting on delivery (the AS-Interface LED flashes alternately red/yellow).

9.3. Configuration in the AS-Interface safety monitor

(see operating instructions for the AS-Interface safety monitor)

9.3.1. Dual-channel dependent

**Cat.
4**

The safety switch is configured in the AS-Interface safety monitor with the AS-Interface address set as follows, for example:

- › Dual-channel conditionally dependent
- › With or without start-up test
- › Synchronization time ≥ 100 ms

9.3.2. Dual-channel positively driven

**Cat.
4**

The safety switch is configured in the AS-Interface safety monitor with the AS-Interface address set as follows, for example:

- › Dual-channel positively driven
- › With or without start-up test

9.4. AS-Interface status messages

A dual LED (red/green) displays the colors red, green and yellow. The following table provides assistance with troubleshooting.

State ASI LED	Explanation
green	Normal operation
red	No data exchange between master and slave Cause: - Master in STOP mode - Slave not in LPS - Slave with wrong IO/ID
red/yellow alternately flashing	No data exchange between master and slave Cause: slave address=0
red/green alternately flashing	Device fault in the slave.
red flashing	

9.5. Safety in case of faults

The AS-Interface power supply and the auxiliary voltage are reverse polarity protected.

9.6. Connection of guard locking control

9.6.1. Guard locking control by means of switching the auxiliary voltage

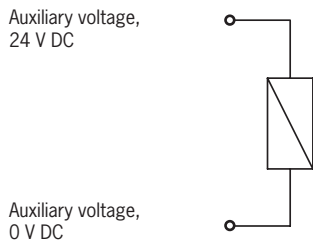

Fig. 2: Connection example: guard locking control by means of switching the auxiliary voltage

9.6.2. Guard locking control via ASi bit D0

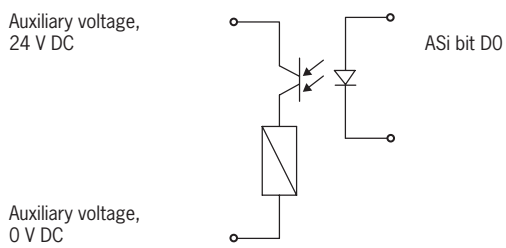

Fig. 3: Connection example: guard locking control via ASi bit D0

10. Setup

10.1. LED displays

You will find a detailed description of the signal functions in chapter 11. *System status table on page 16.*

LED	Color
STATE/DIA	green/red
LOCK	yellow
ASi	green/red/ yellow

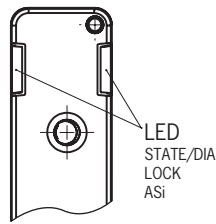

10.2. Teaching-in actuator (only for unicode evaluation)

The actuator must be allocated to the safety switch using a teach-in function before the system forms a functional unit.

The zero sequence is output during a teach-in operation.

The number of possible teach-in operations is unlimited.



Tip!

Prior to switching on, close the guard on which the actuator to be taught-in is installed. The teach-in operation starts immediately after switching on.



Important!

- › The teach-in operation can be performed only if the device does not have any internal fault.
- › Devices in the condition as supplied remain in teach-in standby state until they have successfully taught-in the first actuator. Once taught-in, switches remain in the teach-in standby state for approx. 3 min. after each switch-on.
- › The safety switch disables the code of the preceding device if teach-in is carried out for a new actuator. Teach-in is not possible again immediately for this device if a new teach-in operation is carried out. The disabled code is enabled again in the safety switch only after a third code has been taught-in.
- › The safety switch can be operated only with the last actuator taught-in.
- › If the switch detects the actuator that was most recently taught-in when in the teach-in standby state, this state is ended immediately and the switch changes to normal operation.
- › The actuator to be taught-in is not activated if it is within the actuating range for less than 30 s.

1. Establish teach-in standby:

- Devices in the condition as supplied: unlimited teach-in standby after switching on.
- Switch already taught-in: teach-in standby is available for approx. 3 min after switching on.

➔ Teach-in standby indication, STATE/DIA LED repeatedly flashes 3x green.

2. Insert the actuator during teach-in standby.

➔ The automatic teach-in operation starts (duration approx. 30 s).

During the teach-in operation, the STATE/DIA LED flashes green (approx. 1 Hz).

After successful teach-in, the STATE/DIA and ASi LEDs flash alternately red/green.

Teach-in errors are indicated by the STATE/DIA LED illuminating red and a green flashing code of the STATE/DIA LED (see chapter 11. *System status table on page 16*).

3. Switch off operating voltage (min. 3 s).

➔ The code of the actuator that was just taught-in is activated in the safety switch.

4. Switch on operating voltage.

➔ The device operates normally.

10.3. Functional check



WARNING

Danger of fatal injury as a result of faults in installation and the functional check.

- › Before carrying out the functional check, make sure that there are no persons in the danger area.
- › Observe the valid accident prevention regulations.

10.3.1. Mechanical function test

The actuator must slide easily into the switch. Close the guard several times to check the function.

10.3.2. Electrical function test

After installation and after any fault, the safety function must be fully checked. Proceed as follows:

1. Switch on operating voltage.
 - ➔ The machine must not start automatically.
 - ➔ The safety switch carries out a self-test. The green STATE LED flashes for 5 s at 5 Hz. The STATE/DIA LED then flashes green at regular intervals.
2. Close all guards.
 - ➔ The machine must not start automatically.
 - ➔ The STATE/DIA LED (green) and the yellow LOCK LED are illuminated continuously.
3. Enable operation in the control system.
4. Open the guard.
 - ➔ The machine must switch off and it must not be possible to start it as long as the guard is open.

Repeat steps 2 - 4 for each guard.

Check every safety guard to ensure that activating the guard locking will not affect the safety function.

11. System status table

Operating mode	Actuator/door position	LED indicator, output			State
		STATE/DIA (green)	STATE/DIA (red)	LOCK (yellow)	
Normal operation	off	5 Hz	○	○	Power up
	closed		○		Normal operation, door closed and locked
	closed		○	○	Normal operation, door closed and not locked
	open	1 x	○	○	Normal operation, door open
	open	1 x	○	1 x	Normal operation, door open, ready for guard locking
Teach-in operation (only unicode)	open	3 x	○	○	Device in teach-in standby
	closed	1 Hz	○	○	Teach-in operation
	X	↔		○	Positive acknowledgment after completion of teach-in operation
Fault display	X	1 x		○	Error in the teach-in operation (only unicode) Actuator removed from the actuating range prior to the end of the teach-in operation or disabled actuator detected.
	X	3 x		○	Transponder error (e.g. actuator faulty)
	X	5 x	1 x inverse	○	Environment error (e.g. operating voltage or operating temperature too high)
	X	○		1 x	Plausibility error
	X	○		X	Internal fault
	X	1 x inverse	○	1 x inverse	Locking element stuck
Key to symbols	○			LED not illuminated	
				LED illuminated	
	1 x inverse			LED illuminated, briefly goes off 1 x	
	5 Hz			LED flashes at 5 Hz	
	3 x			LED flashes three times, and this is then repeated	
	↔			LEDs flash alternately	
	X			Any state	

When STATE/DIA flashes red inversely once, the fault display can generally be reset by opening and closing the guard after remedying the cause. If the fault is still displayed afterward, as well as for all other fault displays, briefly interrupt the power supply. Contact EUCHNER if the fault display is not reset after restarting.



Important!

If you do not find the displayed device status in the system status table, this indicates an internal device fault. Contact EUCHNER.

12. Technical data



NOTICE

If a data sheet is available for the product, the information on the data sheet applies.

12.1. Technical data for safety switch CTM-I2-AS2B

Parameter	Value			Unit
	min.	typ.	max.	
General				
Material - Seals - Switch housing	Fluorinated rubber (FKM) Reinforced thermoplastic			
Installation position	Any			
Degree of protection	IP65/IP67/IP69/IP69K (screwed tight with the related mating connector)			
Safety class acc. to EN IEC 61140	III			
Degree of contamination (external, acc. to EN IEC 60947-1)	3 (industrial)			
Mechanical life	1 x 10 ⁶ operating cycles			
Ambient temperature at U _B = 24 V	-20	-	+60	°C
Actuator approach speed	-	-	20	m/min
Actuating/extraction/retention force	Device dependent, see www.euchner.com			N
Locking force F _{max}	1,300			N
Locking force F _{Zh}	F _{Zh} = F _{max} /1.3 = 1,000			N
Weight	Approx. 0.16			kg
Connection (depending on version)	1 plug connector M12, 4-pin			
The following applies to the approval acc. to UL	Operation only with UL class 2 power supply or equivalent measures			
Shock and vibration resistance	Acc. to EN 60947-5-3			
EMC protection requirements	Acc. to EN 60947-5-3			
Ready delay	-	3	-	s
Risk time acc. to EN 60947-5-3	-	-	220	ms
Turn-on time	-	-	400	ms
Solenoid				
Auxiliary voltage	24 +10%/-15% (PELV)			V DC
Current consumption with auxiliary voltage	650			mA
Duty cycle	100			%
AS-Interface data				
		EA code: 7	ID code: B	
AS-i operating voltage	26.5	-	31.6	V DC
Total current consumption from AS-i	CTM-..AS.B	-	50	mA
Valid AS-Interface addresses	1 - 31			
AS-Interface inputs				
		Acc. to ASi Safety at Work		
Influenced by door position	CTM-..AS2..	D0, D1, D2, D3		
AS-Interface outputs				
Guard locking solenoid	D0 (1) = solenoid energized			
Characteristics acc. to EN ISO 13849-1 and EN IEC 62061				
		Monitoring of the guard position		
Category	4			
Performance Level (PL)	e			
PFH _D	4.83 x 10 ⁻⁹			
Maximum SIL	3			
Mission time	20			years

12.1.1. Typical system times

Refer to the technical data for the exact values.

Ready delay: After switch-on, the device carries out a self-test. The system is ready for operation only after this time.

Turn-on time: The max. reaction time t_{on} is the time from the moment when the guard is locked to the moment when the code sequence is transmitted.

Risk time according to EN 60947-5-3: If an actuator moves outside the actuating range, transmission of the code sequence on the corresponding safety switch is deactivated at the latest after the risk time.

12.2. Dimension drawing for safety switch CTM...

Necessary minimum travel + perm. overtravel

Actuator	Length (L)	Necessary minimum travel (h_1) + permissible overtravel (h_2)	Total travel (t)
A-BA1-...	35	21 + 2	56
A-BA5-...	37	21 + 2	58

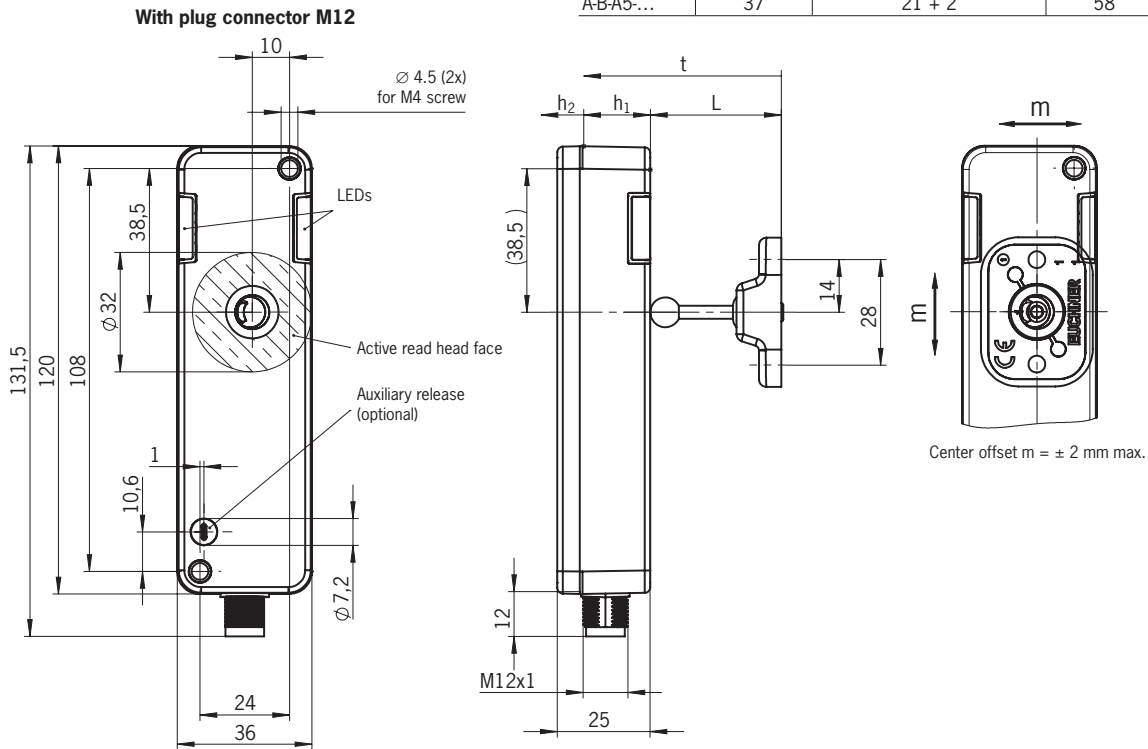

Min. door radius [mm]

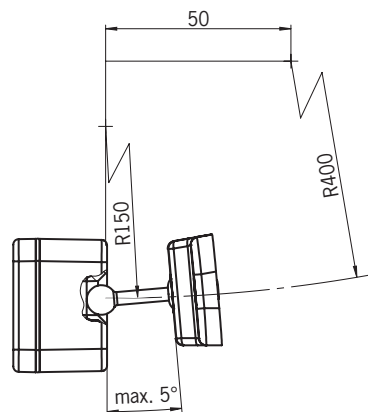

12.3. Technical data for actuator A-B-A1-A1-...

Parameter	Value			Unit
	min.	typ.	max.	
Material				
- Housing	Ultradur black			
- Ball holder	Stainless steel			
- Elastomer	Fluorinated rubber (FKM)			
Resistance	Resistant to chemicals and oil			
Food safe	DIN EN 1672-2, EN ISO 14159, PAH category 3			
Weight	0.0194			kg
Ambient temperature	-20	-	+60	°C
Degree of protection	IP65/IP67/IP69/IP69K			
Mechanical life	1 x 10 ⁶			
Locking force, max.	1,300			N
Locking force F _{Zh}	1,000			N
Installation position	Any			
Overtravel	2			mm
Power supply	Inductive via read head			

12.3.1. Dimension drawing for actuator A-B-A1-A1-...

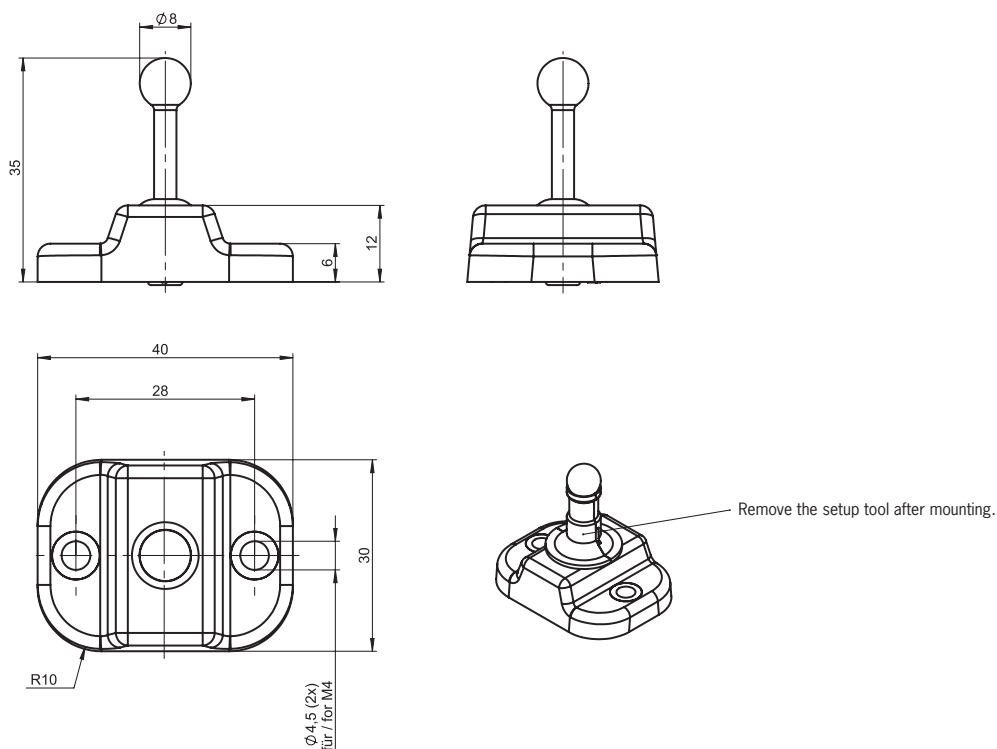

NOTICE

- › The actuator includes two non-removable safety screws.
- › Remove the setup tool after mounting the safety switch and actuator.

12.4. Technical data for actuator A-B-A5-A1-...

Parameter	Value			Unit
	min.	typ.	max.	
Material				
- Housing	Ultradur black			
- Ball holder	Stainless steel			
- Elastomer	NBR			
Resistance	Resistant to chemicals and oil			
Weight	0.0194			kg
Ambient temperature	-20	-	+60	°C
Degree of protection	IP65/IP67/IP69/IP69K			
Mechanical life	1 x 10 ⁶			
Locking force, max.	1,300			N
Locking force F _{Zh}	1,000			N
Installation position	Any			
Overtravel	2			mm
Power supply	Inductive via read head			

12.4.1. Dimension drawing for actuator A-B-A5-A1-...

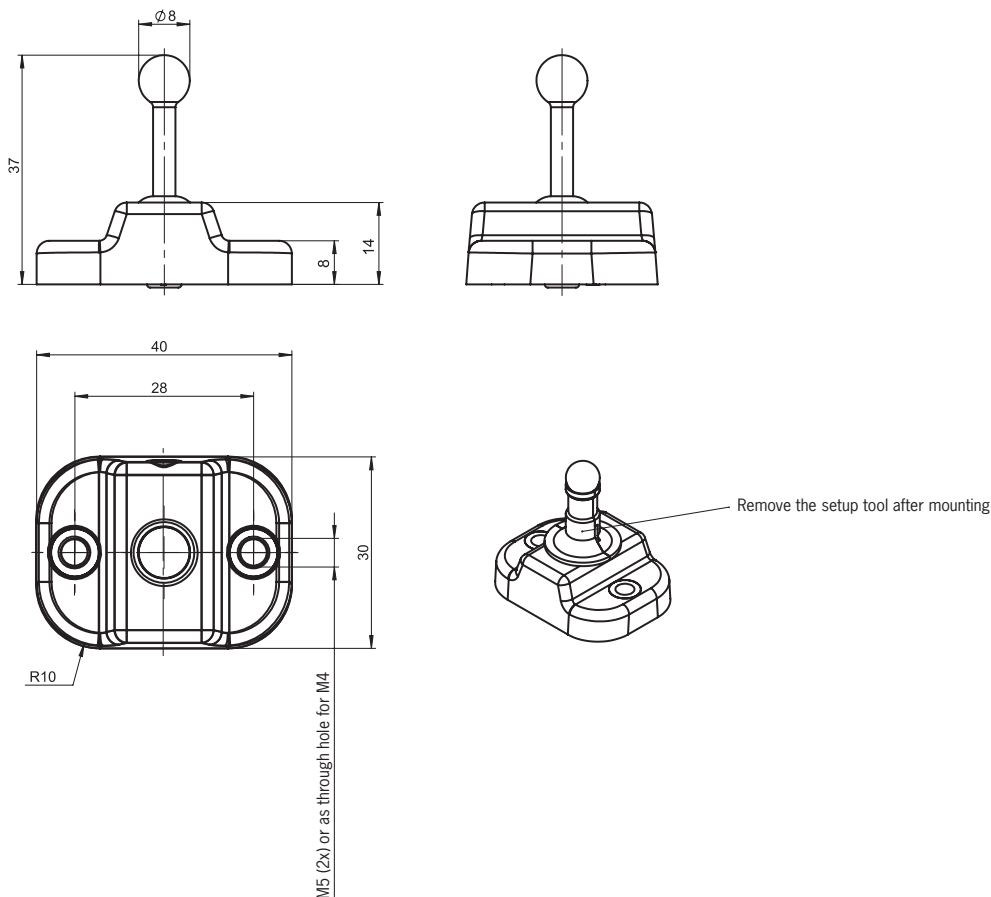

NOTICE

- › The actuator includes two non-removable safety screws.
- › Remove the setup tool after mounting the safety switch and actuator.

13. Ordering information and accessories



Tip!

Suitable accessories, e.g. cables or assembly material, can be found at www.euchner.com. To order, enter the order number of your item in the search box and open the item view. Accessories that can be combined with the item are listed in *Accessories*.

14. Inspection and service



WARNING

Danger of severe injuries due to the loss of the safety function.

- › If damage or wear is found, the complete switch and actuator assembly must be replaced. Replacement of individual parts or assemblies is not permitted
- › Check the device for proper function at regular intervals and after every fault. For information about possible time intervals, refer to EN ISO 14119:2013, section 8.2.

Regular inspection of the following is necessary to ensure trouble-free long-term operation:

- › Check the switching function (see chapter 10.3. *Functional check on page 15*)
- › Check all additional functions (e.g., escape release, lockout bar, etc.)
- › Check the secure mounting of the devices and the connections
- › Check for contamination

No servicing is required. Repairs to the device are only allowed to be made by EUCHNER.



NOTICE

The year of manufacture is given in the laser marking at the bottom right corner. The current version number in the format (V X.X.X) can also be found on the device.

15. Service

If servicing is required, please contact:

EUCHNER GmbH + Co. KG
Kohlhammerstraße 16
70771 Leinfelden-Echterdingen
Germany

Service telephone:
+49 711 7597-500

E-mail:
support@euchner.de

Internet:
www.euchner.com

16. Declaration of conformity

The product complies with the requirements according to Machinery Directive 2006/42/EC.

The EU declaration of conformity can be found at www.euchner.com. Enter the order number of your device in the search box. The document is available under *Downloads*.

EUCHNER GmbH + Co. KG
Kohlhammerstraße 16
70771 Leinfelden-Echterdingen
Germany
info@euchner.de
www.euchner.com

Edition:
MAN20001648-03-04/24
Title:
Operating Instructions Transponder-Coded Safety Switch
CTMH2-AS2B
(translation of the original operating instructions)
Copyright:
© EUCHNER GmbH + Co. KG, 04/2024

Subject to technical modifications; no responsibility is accepted for the accuracy of this information.