

# **EUCHNER**

## **Operating instructions**

**Non-Contact Safety Switch**  
**CES-I-BP-.-C07-... (Unicode/Multicode)**

**EN**

## Contents

<b>1.</b>	<b>About this document</b> .....	<b>4</b>
1.1.	Scope.....	4
1.2.	Target group .....	4
1.3.	Key to symbols.....	4
1.4.	Supplementary documents .....	4
<b>2.</b>	<b>Correct use</b> .....	<b>5</b>
<b>3.</b>	<b>Description of the safety function</b> .....	<b>6</b>
<b>4.</b>	<b>Exclusion of liability and warranty</b> .....	<b>6</b>
<b>5.</b>	<b>General safety precautions</b> .....	<b>6</b>
<b>6.</b>	<b>Function</b> .....	<b>7</b>
6.1.	Limit-range monitoring .....	7
6.2.	Door position monitoring output OD .....	7
6.3.	Communication connection C .....	7
6.4.	Switching states .....	8
<b>7.</b>	<b>Mounting</b> .....	<b>9</b>
<b>8.</b>	<b>Electrical connection</b> .....	<b>10</b>
8.1.	Notes about $\text{cULus}$ .....	11
8.2.	Safety in case of faults.....	11
8.3.	Fuse protection for power supply .....	11
8.4.	Requirements for connecting cables.....	11
8.5.	Connector assignment of safety switch CES-I-BP-.-SB .....	12
8.6.	Connector assignment of safety switch CES-I-BP-.-SI .....	12
8.7.	Notes on operation with safe control systems.....	12
8.8.	Connection.....	13
8.8.1.	Connection without IO-Link communication .....	13
8.8.2.	Connection with IO-Link communication.....	13
<b>9.</b>	<b>Using communication data</b> .....	<b>14</b>
9.1.	Connection to a BR/IO-Link Gateway GWY-CB.....	14
9.2.	Connection to a safety relay ESM-CB.....	14
9.3.	Overview of the communication data .....	14
9.3.1.	Cyclical data (process data).....	14
9.3.2.	Acyclical data (device data and events).....	15

<b>10.</b>	<b>Setup</b> .....	<b>16</b>
10.1.	Teaching-in actuator (only for unicode evaluation) .....	16
10.2.	Electrical function test.....	17
<b>11.</b>	<b>Factory reset</b> .....	<b>17</b>
<b>12.</b>	<b>Status and error messages</b> .....	<b>18</b>
12.1.	LED indicator.....	18
12.2.	Status messages.....	18
12.3.	Error messages.....	19
12.4.	Acknowledging error messages .....	20
<b>13.</b>	<b>Technical data</b> .....	<b>21</b>
13.1.	Technical data for safety switch CES-I-BP-C07-.....	21
13.1.1.	Radio frequency approvals.....	22
13.1.2.	Typical system times.....	23
13.1.3.	Dimension drawing for safety switch CES-I-BP-C07-... ..	23
13.2.	Technical data for actuator CES-A-BTN-C07-... ..	24
13.2.1.	Dimension drawing.....	24
13.2.2.	Actuating ranges and installation positions .....	25
13.3.	Technical data for actuator CES-A-BDN-06-158210.....	27
13.3.1.	Dimension drawing.....	27
13.3.2.	Operating distances* .....	28
<b>14.</b>	<b>Ordering information and accessories</b> .....	<b>29</b>
<b>15.</b>	<b>Inspection and service</b> .....	<b>29</b>
<b>16.</b>	<b>Service</b> .....	<b>29</b>
<b>17.</b>	<b>Declaration of conformity</b> .....	<b>29</b>

## 1. About this document





### 1.1. Scope

These operating instructions apply to all CES-I-BP-.-C07-... of version 1.0.X. These operating instructions, the document *Safety information* and any available data sheet form the complete user information for your device.

### 1.2. Target group







Design engineers and installation planners for safety devices on machines, as well as setup and servicing staff possessing special expertise in handling safety components.

### 1.3. Key to symbols

Symbol/depiction	Meaning
	Printed document
	Document is available for download at <a href="http://www.euchner.com">www.euchner.com</a>
 <b>DANGER</b> <b>WARNING</b> <b>CAUTION</b>	Safety precautions <b>Danger</b> of death or severe injuries <b>Warning</b> about possible injuries <b>Caution</b> slight injuries possible
 <b>NOTICE</b> <b>Important!</b>	<b>Notice</b> about possible device damage <b>Important</b> information
<b>Tip</b>	Useful information

### 1.4. Supplementary documents

The overall documentation for this device consists of the following documents:

Document title (document number)	Contents	
Safety information (2525460)	Basic safety information	
Operating instructions (2528734)	(this document)	
Declaration of conformity	Declaration of conformity	
Possibly available data sheet	Item-specific information about deviations or additions	 
	<b>Important!</b>  Always read all documents to gain a complete overview of safe installation, setup and use of the device. The documents can be downloaded from <a href="http://www.euchner.com">www.euchner.com</a> . For this purpose enter the doc. no. or the order number for the device in the search box.	

## 2. Correct use

Safety switches series CES-I-BP are interlocking devices without guard locking (type 4). The device meets the requirements according to EN IEC 60947-5-3. Devices with unicode evaluation possess a high coding level, devices with multicode evaluation possess a low coding level.

In combination with a movable guard and the machine control, this safety component prevents dangerous machine functions from occurring while the guard is open. A stop command is triggered if the guard is opened during the dangerous machine function.

This means:

- › Starting commands that cause a dangerous machine function must become active only when the guard is closed.
- › Opening the guard triggers a stop command.
- › Closing a guard must not cause automatic starting of a dangerous machine function. A separate start command must be issued. For exceptions, refer to EN ISO 12100 or relevant C-standards.

Before the device is used, a risk assessment must be performed on the machine, e.g. in accordance with the following standards:

- › EN ISO 13849-1
- › EN ISO 12100
- › IEC 62061

Correct use includes observing the relevant requirements for installation and operation, particularly based on the following standards:

- › EN ISO 13849-1
- › EN ISO 14119
- › EN 60204-1

The safety switch is only allowed to be operated in conjunction with the intended EUCHNER CES actuators and the related connection components from EUCHNER. On the use of different actuators or other connection components, EUCHNER provides no warranty for safe function.

	<p><b>Important!</b></p> <ul style="list-style-type: none"> <li>› The user is responsible for the proper integration of the device into a safe overall system. For this purpose, the overall system must be validated, e.g. in accordance with EN ISO 13849-2.</li> <li>› It is only allowed to use components that are permissible in accordance with the table below.</li> </ul>
---	--

Table 1: Possible combinations for CES components

Safety switch	Actuator	
	CES-A-BTN-C07-...	CES-A-BDN-06-...
CES-I-BP-.-C07-...	●	●
Key to symbols	●	Combination possible

### 3. Description of the safety function

Devices from this series feature the following safety functions:

#### Monitoring of the guard position (interlocking device according to EN ISO 14119)

- › Safety function:
  - The safety outputs are switched off when the guard is open (see chapter 6.4. *Switching states on page 8*).
- › Safety characteristics: category, Performance Level, PFH<sub>D</sub> (see chapter 13. *Technical data on page 21*).

### 4. Exclusion of liability and warranty

In case of failure to comply with the conditions for correct use stated above, or if the safety regulations are not followed, or if any servicing is not performed as required, liability will be excluded and the warranty void.

### 5. General safety precautions

Safety switches fulfill personnel protection functions. Incorrect installation or tampering can lead to fatal injuries to personnel.

Check the safe function of the safeguard particularly

- › after any setup work
- › after the replacement of a system component
- › after an extended period without use
- › after every fault

Independent of these checks, the safe function of the safeguard should be checked at suitable intervals as part of the maintenance schedule.



#### **WARNING**

Danger to life due to improper installation or due to bypassing (tampering). Safety components fulfill a personnel protection function.

- › Safety components must not be bypassed, turned away, removed or otherwise rendered ineffective. On this topic pay attention in particular to the measures for reducing the possibility of bypassing according to EN ISO 14119:2013, section 7.
- › The switching operation must be triggered only by actuators designated for this purpose.
- › Prevent bypassing by means of replacement actuators (only for multicode evaluation). For this purpose, restrict access to actuators and to keys for releases, for example.
- › Mounting, electrical connection and setup only by authorized personnel possessing the following knowledge:
  - specialist knowledge in handling safety components
  - knowledge about the applicable EMC regulations
  - knowledge about the applicable regulations on operational safety and accident prevention.



#### **Important!**

Prior to use, read the operating instructions and keep these in a safe place. Ensure the operating instructions are always available during mounting, setup and servicing. You can download the operating instructions from [www.euchner.com](http://www.euchner.com).

## 6. Function

The safety switch monitors the position of movable guards. The safety outputs are switched on/off when the actuator is moved into/out of the actuating range.

The system consists of the following components: coded actuator (transponder) and switch.

Whether the device learns the complete actuator code (unicode) or not (multicode) depends on the respective version.

- › **Devices with unicode evaluation:** The actuator must be assigned to the safety switch by a teach-in operation so that it is detected by the system. This unambiguous assignment ensures a particularly high level of protection against tampering. The system thus possesses a high coding level.
- › **Devices with multicode evaluation:** Unlike systems with unicode evaluation, on multicode devices a specific code is not requested but instead it is only checked whether the actuator is of a type that can be detected by the system (multicode evaluation). There is no exact comparison of the actuator code with the taught-in code in the safety switch (unicode evaluation). The system possesses a low coding level.

When the guard is closed, the actuator is moved towards the safety switch. When the operating distances are reached, power is supplied to the actuator by the switch and data are transferred.

If a permissible code is detected, the safety outputs are switched on.

The safety outputs are switched off when the guard is opened.

In the event of a fault in the safety switch, the safety outputs are switched off and the DIA LED illuminates red. The occurrence of faults is detected at the latest on the next demand to close the safety outputs (e.g. on starting).

### 6.1. Limit-range monitoring

The device detects if the actuator drifts out of the actuating range of the switch over time. The STATE LED or the limit-range signal OW indicates that the actuator is in the limit range (see chapter 12. *Status and error messages on page 18*). Readjusting the door can prevent the actuator from drifting farther out of the actuating range.

### 6.2. Door position monitoring output OD

The device features a monitoring output for the door position signal OD. Depending on the application, the signal is available at the monitoring output or as a status bit. The status bit is evaluated via the BR/IO-Link Gateway. If no BR/IO-Link Gateway is connected, this output behaves like a monitoring output.

The door position signal OD is present when a valid actuator is detected in the actuating range and the guard is closed.

### 6.3. Communication connection C

When the device is connected to a BR/IO-Link Gateway, the monitoring output functions as a communication connection. The switch delivers cyclical and acyclical data. You will find an overview of the communication data in chapter 9.3. *Overview of the communication data on page 14*.

### 6.4. Switching states

The detailed switching states for your switch can be found in chapter 12. *Status and error messages on page 18.* All safety outputs, signals and display LEDs are described there.

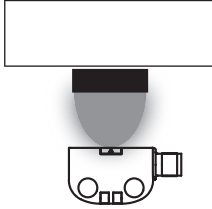
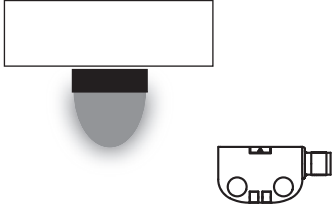
	Guard closed (actuator in the actuating range and permissible code detected)	Guard open (actuator not in the actuating range)
		
Safety outputs FO1A and FO1B	on	off
Door position signal OD	on	off



## 7. Mounting



### CAUTION

Safety switches must not be bypassed (bridging of contacts), turned away, removed or otherwise rendered ineffective.

- › Observe EN ISO 14119:2013, section 7, for information about reducing the possibilities for bypassing an interlocking device.



### NOTICE

Risk of damage to equipment and malfunctions as a result of incorrect installation.

- › Safety switches and actuators must not be used as an end stop.
- › Observe EN ISO 14119:2013, sections 5.2 and 5.3, for information about mounting the safety switch and the actuator.
- › From the assured release distance  $S_{ar}$ , the safety outputs are safely shut down.
- › When mounting several safety switches, observe the stipulated minimum distance to avoid mutual interference.

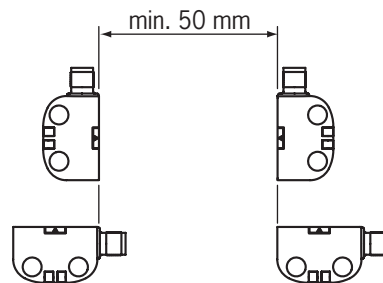

- › The operating distances change during the mounting of the actuator as a function of the material used for the guard.
- › Observe direction of arrow on the device (see figure below).

Permissible installation positions

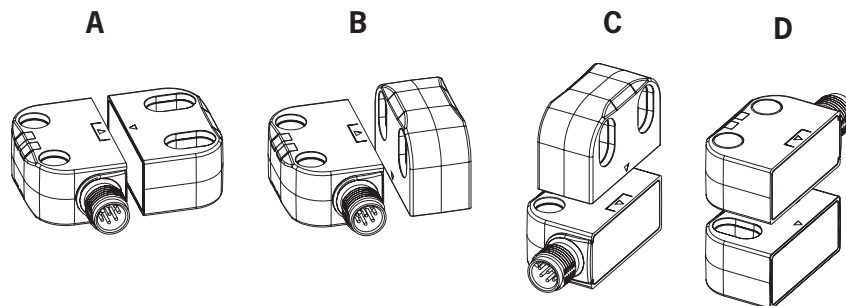

### Note the following points:

- › Actuator and safety switch must be easily accessible for inspection and replacement.
- › Actuator and safety switch must be fitted so that
  - a minimum distance is maintained with a side approach direction to avoid entering the area of possible side lobes. See chapter 13. *Technical data*, section *Typical actuating range* for the related actuator.
  - when the guard is open up to the distance  $S_{ar}$  (assured release distance), a hazard is excluded.
  - the actuator is positively mounted on the guard, e.g. by using the safety screws included.
  - the safety screws cannot be removed or tampered with using simple means.
- › Pay attention to the maximum tightening torque for the safety switch and actuator mountings of 0.8 Nm.
- › Seal the mounting holes after mounting using the caps provided to prevent the accumulation of dirt.
- › In order to prevent damage, the connecting cable must be laid with protection in areas in which high-pressure cleaners are used.

## 8. Electrical connection

The following connection options are available:

- › Connection without IO-Link communication
- › Connection with IO-Link communication



### WARNING

In the event of a fault, loss of the safety function due to incorrect connection.

- › To ensure safety, both safety outputs must always be evaluated.
- › Monitoring outputs must not be used as safety outputs.
- › Lay the connecting cables with protection to prevent short circuits.



### CAUTION

Risk of damage to equipment or malfunctions as a result of incorrect connection.

- › Do not use a control system with pulsing or switch off the pulsing function in your control system. The device generates its own test pulses on the safety outputs. A downstream control system must tolerate these test pulses, which may have a length of up to 300  $\mu$ s. Depending on the inertia of the downstream device (control system, relay, etc.), this can lead to short switching processes. The test pulses are output only with the safety outputs switched off during device start.
- › The inputs on a connected evaluation unit must be positive switching, as the two outputs on the safety switch deliver a level of +24 V in the switched-on state.
- › All the electrical connections must either be isolated from the mains supply by a safety transformer according to IEC 61558-2-6 with limited output voltage in the event of a fault, or by other equivalent insulation measures (PELV).
- › All electrical outputs must have an adequate protective circuit for inductive loads. The outputs must be protected with a free-wheeling diode for this purpose. RC interference suppression units must not be used.
- › Power devices which are a powerful source of interference must be installed in a separate location away from the input and output circuits for signal processing. The cable routing for safety circuits should be as far away as possible from the cables of the power circuits.
- › To avoid EMC interference, the physical environmental and operating conditions at the installation site of the device must comply with the requirements according to the standard EN 60204-1 (EMC).
- › Pay attention to any interference fields from devices such as frequency converters or induction heating systems. Observe the EMC instructions in the manuals from the respective manufacturer.



### Important!

If the device does not appear to function when operating voltage is applied (e.g. green STATE LED does not flash), the safety switch must be returned unopened to the manufacturer.

### 8.1. Notes about



#### Important!

- › This device is intended to be used with a Class 2 power source in accordance with UL1310. As an alternative an LV/C (Limited Voltage/Current) power source with the following properties can be used:
  - This device shall be used with a suitable isolating source in conjunction with a fuse in accordance with UL248. The fuse shall be rated max. 3.3 A and be installed in the max. 30 V DC power supply to the device in order to limit the available current to comply with the UL requirements. Please note possibly lower connection ratings for your device (refer to the technical data).
- › For use and application as per the requirements of  1) a connecting cable listed under the UL category code CYJV2 or CYJV must be used.

1) Note on the scope of the UL approval: the devices have been tested as per the requirements of UL508 and CSA/ C22.2 no. 14 (protection against electric shock and fire). Only for applications as per NFPA 79 (Industrial Machinery).

### 8.2. Safety in case of faults

- › The operating voltage  $U_B$  is reverse polarity protected.
- › The safety outputs are short circuit-proof.
- › A short circuit between the safety outputs is detected on starting or when the safety outputs are activated by the device.
- › A short circuit in the cable can be excluded by laying the cable with protection.

### 8.3. Fuse protection for power supply

The power supply must be provided with fuse protection depending on the number of switches and the current required for the outputs. The following rules apply:

#### Max. current consumption of an individual switch $I_{max}$

$$I_{max} = I_{UB} + I_{OD} + I_{F01A+F01B}$$

$$I_{UB} = \text{Switch operating current (40 mA)}$$

$$I_{OD} = \text{Load current of monitoring output (max. 50 mA)}$$

$$I_{F01A+F01B} = \text{Load current of safety outputs F01A + F01B (2 x max. 150 mA)}$$

### 8.4. Requirements for connecting cables



#### CAUTION

Risk of damage to equipment or malfunctions as a result of incorrect connecting cables.

- › Use connection components and connecting cables from EUCHNER.
- › On the use of other connection components, the requirements in the following table apply. EUCHNER provides no warranty for safe function in case of failure to comply with these requirements.
- › Observe the maximum cable length of 200 m.

Observe the following requirements with respect to the connecting cables:

Parameter	Value		Unit
	M12 / 5-pin		
Recommended cable type	LIYY 5 x 0.25	LIYY 5 x 0.34	mm <sup>2</sup>
Cable	5 x 0.25	5 x 0.34	mm <sup>2</sup>
Cable resistance R max.	78	58	Ω/km
Inductance L max.	0.64	0.53	mH/km
Capacitance C max.	60	100	nF/km

## 8.5. Connector assignment of safety switch CES-I-BP-...-SB

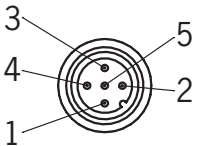
Plug connector (view of connection side)	Pin	Designation	Function	Conductor coloring of connecting cable <sup>1)</sup>
	1	UB	Operating voltage, 24 V DC	BN
	2	F01A	Safety output, channel A	WH
	3	0 V	Ground 0 V DC	BU
	4	F01B	Safety output, channel B	BK
	5	OD/C	Door position monitoring output/communication	GY

1) Only for standard EUCHNER connecting cable

## 8.6. Connector assignment of safety switch CES-I-BP-...-SI

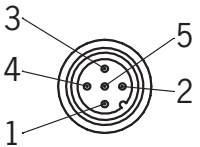
Plug connector (view of connection side)	Pin	Designation	Function	Conductor coloring of connecting cable <sup>1)</sup>
	1	UB	Operating voltage, 24 V DC	BN
	2	F01A	Safety output, channel A	WH
	3	0 V	Ground 0 V DC	BU
	4	F01B	Safety output, channel B	BK
	5	-	n.c.	GY

1) Only for standard EUCHNER connecting cable

## 8.7. Notes on operation with safe control systems

Observe the following guidelines for connection to safe control systems:

- › Use a common power supply for the control system and the connected safety switches.
- › The device tolerates voltage interruptions at UB up to 5 ms in duration, provided that the time between two voltage interruptions is at least 500 ms.
- › Tap the supply voltage directly from the power supply unit. If the power supply is connected to a terminal of a safe control system, this output must provide sufficient electrical current.
- › The safety outputs F01A and F01B can be connected to the safe inputs of a control system. Prerequisite: the input must be suitable for pulsed safety signals (OSSD signals, e.g. from light grids). The control system must tolerate test pulses on the input signals. This normally can be set up by parameter assignment in the control system. Observe the notes of the control system manufacturer. For the test pulse duration of your safety switch, refer to chapter 13. *Technical data on page 21.*

A detailed example of connecting and setting the parameters of the control system is available for many devices at [www.euchner.com](http://www.euchner.com), in the area *Downloads/Applications/CES*. The features of the respective device are dealt with there in greater detail.

### 8.8. Connection

The device is connected as shown in Fig. 1. The monitoring output OD can be connected to a control system.



#### WARNING

In the event of a fault, loss of the safety function due to incorrect connection.  
 › To ensure safety, both safety outputs FO1A and FO1B must always be evaluated.



#### Important!

The example shows only an excerpt that is relevant for the connection of the CES system. The example illustrated here does not show complete system planning. The user is responsible for safe integration into the overall system. Detailed application examples can be found at [www.euchner.com](http://www.euchner.com). Simply enter the order number of your switch in the search box. You will find all available connection examples for the device in *Downloads*.

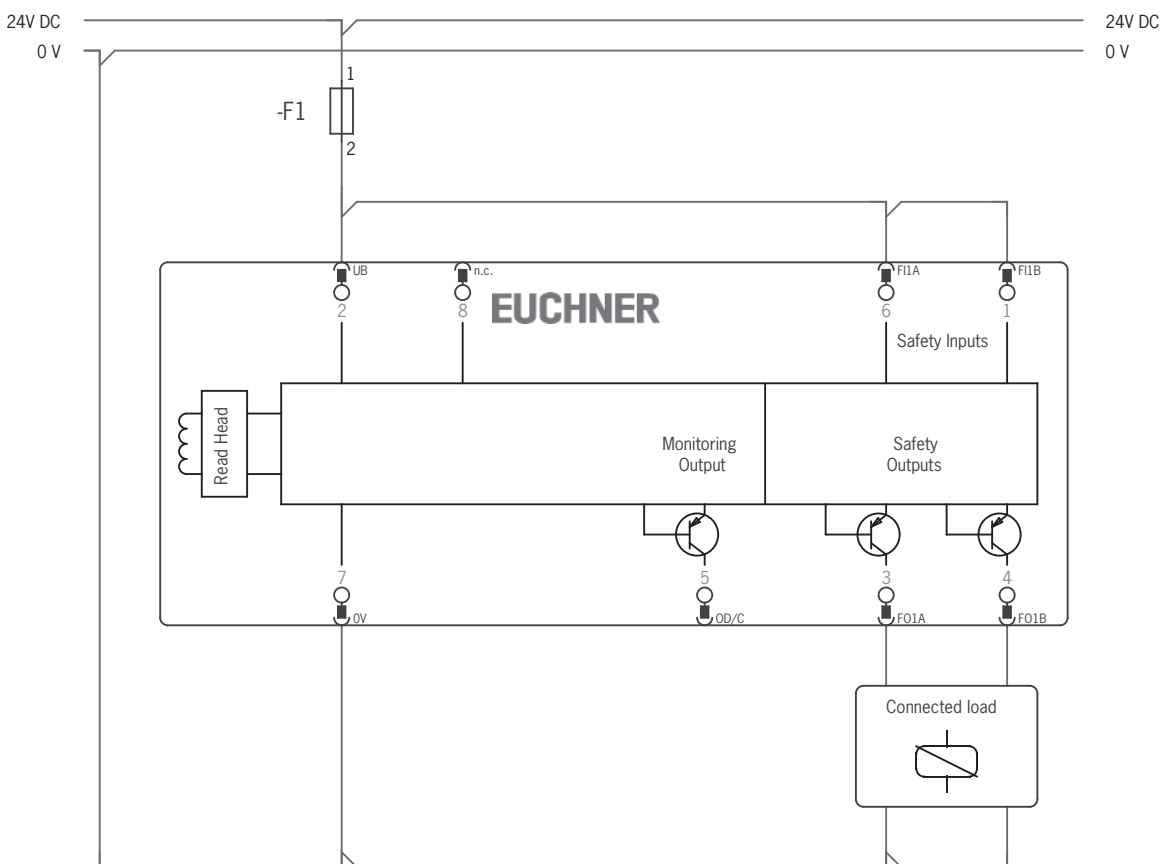

Fig. 1: Connection example CES-I-BP-...

#### 8.8.1. Connection without IO-Link communication

Only the safety and monitoring outputs are switched with this connection method.

#### 8.8.2. Connection with IO-Link communication

If, in addition to the safety function, detailed monitoring and diagnostic data are to be processed, a BR/IO-Link Gateway is required.

To poll the communication data from the connected device, communication connection C is routed to the BR/IO-Link Gateway. You will find further information in the operating instructions for your BR/IO-Link Gateway.

## 9. Using communication data

A BR/IO-Link Gateway is required to use the device's communication data and forward them to a higher-level bus system. The following devices are suitable:

- › GWY-CB-1-BR-IO (BR/IO-Link Gateway)
- › ESM-CB (safety relay with integrated BR/IO-Link Gateway)

### 9.1. Connection to a BR/IO-Link Gateway GWY-CB

The Gateway is an IO-Link device. Communication via IO-Link offers cyclical (process data) and acyclical (device data and events) data exchange (see chapter 9.3. *Overview of the communication data on page 14*).

The communication connection C on the device allows the diagnostic line to be connected to the Gateway. The OD/C connection represents a non-safety-related communication channel between the Gateway and the connected devices.

IO-Link communication can be used for the following functions as well:

- › Reset for acknowledging error messages

You will find further information in the operating instructions for your BR/IO-Link Gateway.

### 9.2. Connection to a safety relay ESM-CB

The safety relay ESM-CB features an integrated BR/IO-Link Gateway. In addition to functioning as an IO-Link device (see chapter 9.1. *Connection to a BR/IO-Link Gateway GWY-CB on page 14*), the device can be used for connecting two monitored single- or dual-channel sensor circuits. The sensor circuits evaluate various signaling devices:

- › Sensor circuit S1 with short circuit detection; suitable for single- or dual-channel safety sensors
- › Sensor circuit S2, suitable for OSSD signals; short circuit detection by signaling device

When at least one sensor circuit is interrupted, the safety relay initiates the safe state. Different relay starting behaviors and various monitoring functions are possible.

The device's safety outputs FO1A and FO1B are routed to the OSSD inputs of the safety relay. The OD/C connection of the device allows the diagnostic line to be connected to the Gateway.

You will find further information in the operating instructions for your safety relay with integrated BR/IO-Link Gateway.

### 9.3. Overview of the communication data

The switch transmits both process data that are continuously transmitted to the evaluation unit (cyclical data) and data that can be polled specifically as needed (acyclical data). For further information on connection and on the communication data, refer to the operating instructions for your BR/IO-Link Gateway.

#### 9.3.1. Cyclical data (process data)

Table 2: Cyclical data (process data)

	Bit 7	Bit 6	Bit 5	Bit 4	Bit 3	Bit 2	Bit 1	Bit 0
Byte 1	OI	-	-	-	OM	-	OW	OD

Bit	Signal	Message
OI	Diagnostics	There is a fault, see 12.3. <i>Error messages on page 19</i> .
OM	Status	The safety outputs of the device are switched.
OW	Limit range	The actuator is in the limit range of the switch's operating distances.
OD	Door position	A valid actuator is detected in the actuating range, and the guard is closed.

### 9.3.2. Acyclical data (device data and events)

After one of the commands listed below is sent, the requested data are provided via the IO-Link Gateway. The reply message always consists of 8 bytes.

**Example 1:** reply message in response to the command *Send device ID number/serial number*: 06 **E0 68 02 17 01 00 00**

In this example, the device's ID number is **157920** and its serial number is **279**.

Byte number	Byte 0	Byte 1	Byte 2	Byte 3	Byte 4	Byte 5	Byte 6	Byte 7
Reply in hex	06	E0	68	02	17	01	00	00
Description	User data length in bytes	Device ID number			Serial number			Padding data
Reply in dec.	6 bytes	157920			279			-

**Example 2:** reply message in response to the command *Send current actuator code*: 05 xx xx **00 5F** xx 00 00

In this example, the device's actuator code is **1**.

Byte number	Byte 0	Byte 1	Byte 2	Byte 3	Byte 4	Byte 5	Byte 6	Byte 7
Reply in hex	05			00	5F		00	00
Description	User data length in bytes			Current actuator code (10 bits)			Padding data	
Reply in bits				0 0 0 0 0 0 0 0 0 1	0 1 1 1 1 1 1			
Reply in dec.	5 bytes			1			-	-

Command		Reply		
HEX	Meaning	Number of bytes	Bit sequences	Format
2	Send device ID number/serial number	6	Bytes 1 - 3: Device ID number Bytes 4 - 6: Serial number	Little endian
3	Send version number of the device	5	Byte 1: (V) Bytes 2 - 4: Version number	Big endian
12	Send current error code	1		
13	Send most recently saved error code	1		
14	Send size of log file	1		
15	Send entry from log file with index	1		
16	Send current actuator code	5	Bytes 3 - 4: see example 2 above	
17	Send taught-in actuator code <sup>1)</sup>	5	Bytes 3 - 4: see example 2 above	
18	Send disabled actuator code <sup>1)</sup>	5	Bytes 3 - 4: see example 2 above	
19	Send applied voltage in mV	2		Little endian
1 A	Send current temperature in °C <sup>2)</sup>	1		Big endian
1B	Send number of switching cycles	3		Little endian
1D	Reset for acknowledging error messages	-		Big endian
1E	Factory reset	1	0x1E – Factory reset performed	

1) On devices with multicode evaluation, reply message 05 is **FF FF FF FF FF 00 00**.

2) The read value is the internal operating temperature in the device. This value can exceed the ambient temperature. The device enters the fault state when the internal operating temperature exceeds 80 °C.

For more information on these and other acyclical data, refer to the operating instructions for your BR/IO-Link Gateway.

## 10. Setup

### 10.1. Teaching-in actuator (only for unicode evaluation)

The actuator must be allocated to the safety switch using a teach-in operation before the system forms a functional unit.

During a teach-in operation, the safety outputs and the door position signal OD are switched off, i.e. the system is in the safe state.



**Tip!**

It is recommended to perform the teach-in operation prior to mounting. Mark switches and actuators that belong together in order to prevent confusion.



**Important!**

- › The teach-in operation may be performed only if the device functions flawlessly. The red DIA LED must not be illuminated.
- › The safety switch disables the code of the preceding device if teach-in is carried out for a new actuator. Teach-in is not possible again immediately for this device if a new teach-in operation is carried out. The disabled code is released again in the safety switch only after a third code has been taught-in.
- › The safety switch can be operated only with the last actuator taught-in.
- › The number of teach-in operations is unlimited.
- › If the switch detects the actuator that was most recently taught-in when in the teach-in standby state, this state is ended immediately and the switch changes to normal operation.
- › If the actuator to be taught-in is within the actuating range for less than 30 s, it will not be activated and the most recently taught-in actuator will remain saved.

1. Apply operating voltage to the safety switch.

➔ The green LED flashes quickly (approx. 5 Hz)

A self-test is performed during this time (approx. 5 s). After this, the LED flashes cyclically three times and signals that it is in teach-in standby state.

Teach-in standby state remains active for approx. 3 minutes. On switches that have not been taught in, teach-in standby is unlimited.

2. Move new actuator to the read head (observe distance  $< S_{a0}$ ).

➔ Teach-in operation starts; green LED flashes slowly. During the teach-in operation, the safety switch checks whether the actuator is a disabled actuator. After successful teach-in, the green STATE LED and the red DIA LED flash alternately. The new code has now been stored, and the old code is disabled. The teach-in operation takes approx. 30 s.

3. Disconnect safety switch from the operating voltage for 3 seconds.

➔ The switch is in normal operation after the self-test.



## 10.2. Electrical function test



### WARNING

Danger of fatal injury as a result of faults in installation and the functional check.

- › Before carrying out the functional check, make sure that there are no persons in the danger zone.
- › Observe the valid accident prevention regulations.

After installation and after any fault, the safety function must be fully checked. Proceed as follows:

1. Switch on operating voltage.
  - ➔ The machine must not start automatically.
  - ➔ The safety switch carries out a self-test. The green STATE LED flashes for 5 s at 5 Hz. The green STATE LED then flashes at regular intervals.
2. Close all guards.
  - ➔ The machine must not start automatically.
  - ➔ The green STATE LED illuminates continuously.
3. Enable operation in the control system.
4. Open the guard.
  - ➔ The machine must switch off and it must not be possible to start it as long as the guard is open.
  - ➔ The green STATE LED flashes at regular intervals.

Repeat steps 2 - 4 for each guard.

## 11. Factory reset

A factory reset deletes the configuration and restores the device's factory settings.

To perform a factory reset, connect the two outputs FO1A and FO1B to 0 V before switching on or send the command Ox1E via IO-Link communication (see chapter 9.3.2. *Acyclical data (device data and events) on page 15*).

## 12. Status and error messages

### 12.1. LED indicator

LED	Color
STATE	green
DIA	red

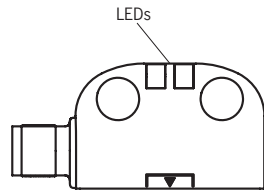

#### Important!

If you do not find the displayed device status in the following tables, this indicates an internal device fault. Contact the manufacturer.

Key to symbols	○		LED not illuminated
			LED illuminated
	1 x inverse		LED illuminated, briefly goes off 1 x
	quickly		LED flashes quickly (5 Hz)
	slowly		LED flashes slowly (1 Hz)
	3 x		LED repeatedly flashes three times
			LEDs flash alternately

### 12.2. Status messages

Operating mode	LED indicator		Safety outputs F01A / F01B	Door position signal OD	Status
	STATE green	DIA red			
Selftest	quickly (1 s)	○	off	off	Self-test after operating voltage is switched on.
	quickly	1 x			No communication with the BR/IO-Link Gateway.
Normal operation		○	on	on	Door is closed.
	1 x		off	off	Door is open.
	6 x inverse		on	on	Door is closed. The actuator is in the limit range. Door must be readjusted.
Teach-in operation	3 x	○	off	off	Device is in teach-in standby (see chapter 10.1. Teaching-in actuator (only for unicode evaluation) on page 16).
	slowly			off	Teach-in operation. Door is closed.
				off	Positive acknowledgment after successful teach-in operation.
Error		or 1x inverse	off	depending on the error	Error message (see chapter 12.3. Error messages on page 19)

### 12.3. Error messages

Error code via IO-Link	LED indicator		Error	Troubleshooting	Ac-knowledging errors	
	STATE green	DIA red			Opening/closing door	Reset
<b>Teach-in errors</b>						
0x1F			Actuator removed from the actuating range prior to the end of the teach-in operation.	Check whether the actuator is outside the actuating range or in the limit range.		●
0x25			Disabled actuator detected during the teach-in operation: The actuator was taught-in during the penultimate teach-in operation and is disabled for the current teach-in operation.	Repeat the teach-in operation with a new actuator (see chapter 10.1. <i>Teaching-in actuator (only for unicode evaluation) on page 16</i> ).		●
0x42			Invalid or faulty actuator detected during teach-in operation.	Repeat teach-in operation with valid actuator.		●
<b>Transponder/read errors</b>						
-			Invalid actuator detected.	Replace actuator.		●
<b>Output errors</b>						
0x4C 0x4D			A HIGH signal or short circuit is detected at safety output FO1A or FO1B during the self-test.	Check wiring.		●
0x54			The voltage level at safety outputs FO1A and FO1B during operation does not meet the requirements. External voltage or a short-circuit may exist.			●
<b>Environment errors</b>						
0x60			Supply voltage too high.	Decrease supply voltage.		●
0x61			Supply voltage too low.	<ul style="list-style-type: none"> <li>▸ Increase supply voltage.</li> <li>▸ Check system configuration: cable length, number of devices in the switch chain.</li> </ul>		●
0x62			Device temperature too high.	Observe the specified temperature range (see chapter 13. <i>Technical data on page 21</i> ).		●
0x63			Device temperature too low.			●
<b>Internal error</b>						
0x01 or -	○		In case of series connection with IO-Link communication: Safety input FI1A is routed to safety output FO1B of the previous device.	Check wiring.		●
			<ul style="list-style-type: none"> <li>▸ Internal device error</li> <li>▸ Supply voltage extremely high or extremely low.</li> <li>▸ Device temperature extremely high or extremely low.</li> </ul>	<ul style="list-style-type: none"> <li>▸ Check supply voltage.</li> <li>▸ Check device temperature.</li> <li>▸ Restart the device. On repeated occurrence, contact the manufacturer.</li> </ul>		●

## 12.4. Acknowledging error messages

If the DIA LED flashes inversely once, the error message can be acknowledged by opening and closing the guard. If the error is still displayed afterward, a reset must be performed.

If the DIA LED is permanently illuminated, the error message can be acknowledged only by a reset.

The reset can be performed as follows.

Reset	Centrally for all devices in a chain	Each device must be addressed individually	Further information
By briefly disconnecting the power supply	●	-	-
Via the cyclical data of IO-Link communication	●	-	See operating instructions for the IO-Link Gateway
Via the acyclical data of IO-Link communication	-	●	See chapter 9.3.2. <i>Acyclical data (device data and events)</i> on page 15

Resetting to acknowledge error messages does not delete the configuration.



**Important!**

Contact the manufacturer if the fault display is not reset after briefly disconnecting the power supply.

### 13. Technical data



#### NOTICE

If a data sheet is available for the product, the information on the data sheet applies.

#### 13.1. Technical data for safety switch CES-I-BP-C07-...

Parameter	Value			Unit
	min.	typ.	max.	
Housing material	Plastic PBT-PC-GF30			
Dimensions	40 x 26.5 x 18			mm
Weight (device without connecting cable)	0.08			kg
Ambient temperature at $U_B = 24$ V DC	- 25	-	+ 55 (with all outputs at full load) + 65 (when switching max. 10 mA per safety output)	°C
Storage temperature	- 40	-	+ 70	
Operating altitude	-	-	4,000	m
Degree of protection	IP65/IP67/IP69/IP69K			
Safety class	III			
Degree of contamination	3			
Installation orientation	Any			
Mounting method	Non-flush			
Connection	Plug connector M12, 5-pin			
Operating voltage $U_B$ (regulated, residual ripple < 5%)	24 ± 15% (PELV)			V DC
Current consumption	40			mA
External fuse (operating voltage)	0.25	-	8	A
Safety outputs FO1A/FO1B - Output voltage $U_{FO1A}/U_{FO1B}$ <sup>1)</sup>	Semiconductor outputs, p-switching, short circuit-proof			
HIGH $U_{FO1A}$	$U_B-1.5$	-	$U_B$	V DC
HIGH $U_{FO1B}$				
LOW $U_{FO1A}/U_{FO1B}$	0		1	
Switching current per safety output	1	-	150	mA
Utilization category acc. to EN IEC 60947-5-2	DC-13 24 V 150 mA Caution: Outputs must be protected by a free-wheeling diode in the case of inductive loads.			
Off-state current $I_r$	-	-	0.25	mA
Door position monitoring output OD/C <sup>1)</sup> - Output voltage	p-switching, short circuit-proof			
HIGH	$U_B-1.5$	-	$U_B$	V DC
LOW	0	-	1	
- Switching current	1	-	50	mA
Rated insulation voltage $U_i$	300			V
Rated impulse withstand voltage $U_{imp}$	1.5			kV
Conditional short-circuit current	100			A
Shock and vibration resistance	Acc. to EN IEC 60947-5-3			
Switching frequency	-	-	1	Hz
Repeat accuracy R	-	-	10	%
EMC protection requirements	Acc. to EN IEC 60947-5-3			
Ready delay	-	5	-	s
Risk time	-	-	125	ms
Reaction time <sup>2)</sup>	27.4			ms
Turn-on time	-	-	100	ms
Discrepancy time	-	-	10	ms
Test pulse duration	0.3			ms
Test pulse interval	Approx. 100			ms

Reliability values acc. to EN ISO 13849-1 <sup>3)</sup>		
Category	4	
Performance Level	PL e	
PFH <sub>D</sub>	6 x 10 <sup>-10</sup> / h	
Mission time	20	years
Reliability values acc. to EN 62061	Maximum SIL 3	

1) Values at a switching current of 50 mA without taking into account the cable lengths.

2) The reaction time is the time until the moment when at least one of the safety outputs F01A oder F01B switches off when the actuator is removed from the actuating range, given compliance with the manufacturer's specifications.

3) Refer to the declaration of conformity in chapter 17 for the issue date.

### 13.1.1. Radio frequency approvals

**FCC ID: 2AJ58-12**

**IC: 22052-12**

#### FCC/IC-Requirements

This device complies with part 15 of the FCC Rules and with Industry Canada's licence-exempt RSSs. Operation is subject to the following two conditions:

- 1) This device may not cause harmful interference, and
- 2) this device must accept any interference received, including interference that may cause undesired operation.

Changes or modifications not expressly approved by the party responsible for compliance could void the user's authority to operate the equipment.

NOTE: This equipment has been tested and found to comply with the limits for a Class A digital device, pursuant to part 15 of the FCC Rules. These limits are designed to provide reasonable protection against harmful interference when the equipment is operated in a commercial environment. This equipment generates, uses, and can radiate radio frequency energy and, if not installed and used in accordance with the instruction manual, may cause harmful interference to radio communications. Operation of this equipment in a residential area is likely to cause harmful interference in which case the user will be required to correct the interference at his own expense.

Le présent appareil est conforme aux CNR d'Industrie Canada applicables aux appareils radio exempts de licence. L'exploitation est autorisée aux deux conditions suivantes :

- (1) l'appareil ne doit pas produire de brouillage, et
- (2) l'utilisateur de l'appareil doit accepter tout brouillage radioélectrique subi, même si le brouillage est susceptible d'en compromettre le fonctionnement.

#### Supplier's Declaration of Conformity

##### 47 CFR § 2.1077 Compliance Information

##### Unique Identifier:

CES-I-BP series

##### Responsible Party – U.S. Contact Information

##### EUCHNER USA Inc.

1860 Jarvis Avenue  
Elk Grove Village, Illinois 60007

+1 315 701-0315

info(at)euchner-usa.com

http://www.euchner-usa.com

### 13.1.2. Typical system times

Refer to the technical data for the exact values.

**Ready delay:** After switch-on, the device carries out a self-test. The system is ready for operation only after this time.

**Turn-on time of safety outputs:** The max. reaction time  $t_{on}$  is the time from the moment when the actuator is in the actuating range to the moment when the safety outputs switch on.

**Risk time according to EN 60947-5-3:** The risk time is the maximum time until at least one of the safety outputs FO1A or FO1B switches off safely when the actuator is removed from the actuating range. This also applies if an internal or external fault occurs at this moment.

**Discrepancy time:** The safety outputs FO1A and FO1B switch with a slight time offset. They have the same signal state no later than after the discrepancy time.

**Test pulses at the safety outputs:** The device generates its own test pulses on the safety outputs FO1A and FO1B. A downstream control system must tolerate these test pulses.

This can usually be set up in the control systems by parameter assignment. If parameter assignment is not possible for your control system or if shorter test pulses are required, contact our support organization.

### 13.1.3. Dimension drawing for safety switch CES-I-BP-C07-...

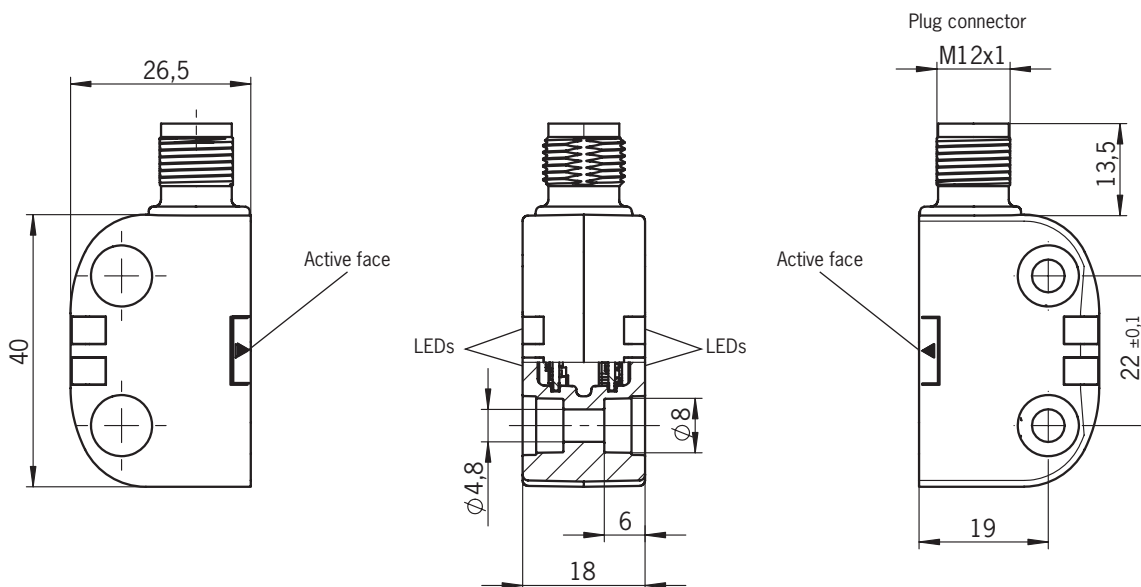

#### NOTICE

› Covers included.

**13.2. Technical data for actuator CES-A-BTN-C07-...**

Parameter	Value			Unit
	min.	typ.	max.	
Housing material	Plastic PBT-PC-GF30			
Dimensions	40 x 26.5 x 18			mm
Weight	0.03			kg
Ambient temperature	- 40	-	+ 65	°C
Degree of protection	IP65/IP67/IP69/IP69K			
Installation orientation	Active face opposite switch			
Power supply	Inductive via switch			

**13.2.1. Dimension drawing**

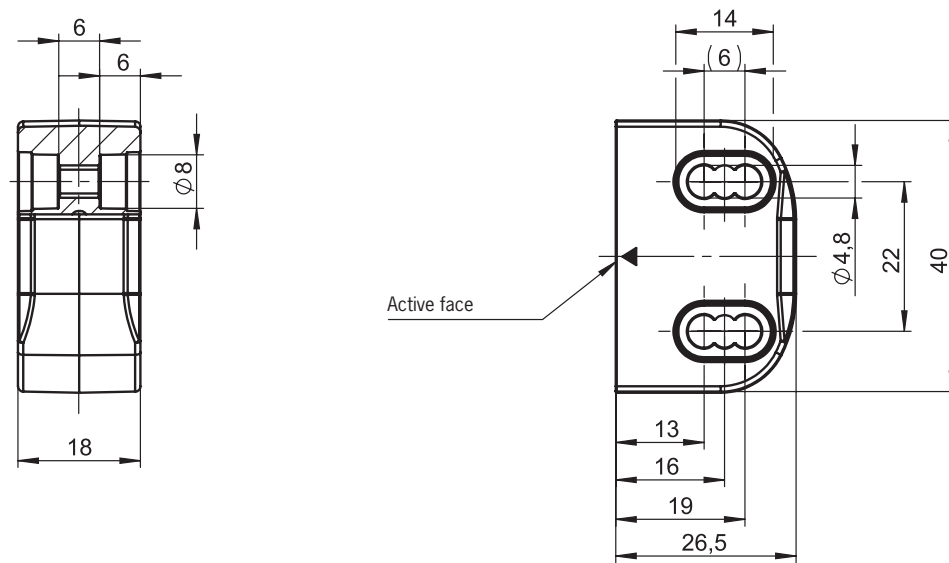

**NOTICE**

› 2 safety screws M4x20 included.



### 13.2.2. Actuating ranges and installation positions

(only in conjunction with actuator CES-A-BTN-C07)

#### Typical actuating range in installation position A

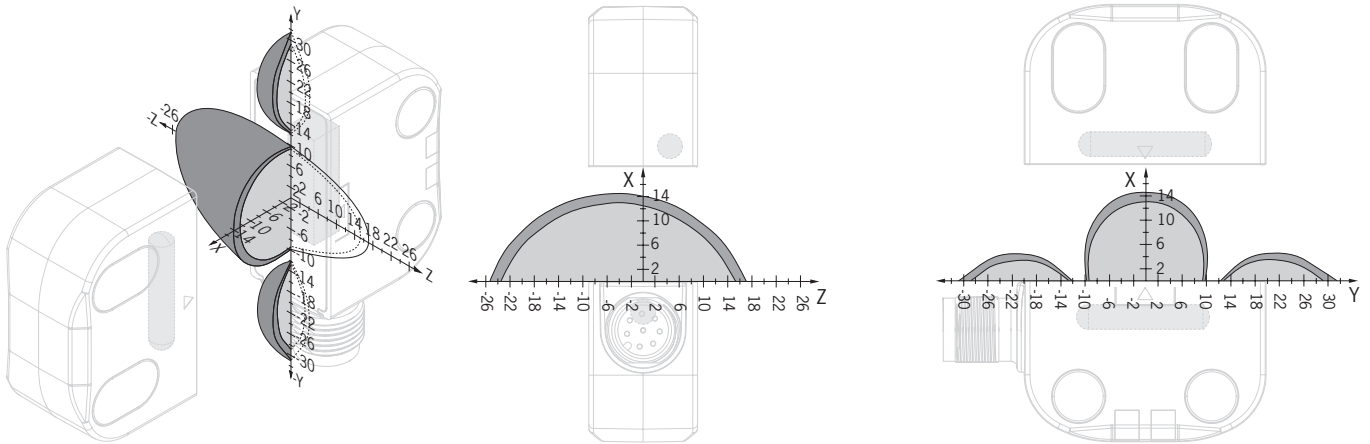

#### Operating distances for approach from x direction without center offset ( $z, y = 0$ )\*

Parameter	Value			Unit
	min.	typ.	max.	
Operating distances	-	13	-	mm
Assured operating distances $s_{ao}$	10	-	-	
Switching hysteresis <sup>1)</sup>	1	2	-	
Assured release distance $s_{ar}$	-	-	20	

\* The data apply to mounting the actuator on a non-metallic substrate. Depending on the substrate material, the actuating range may change.

#### Typical actuating range in installation position B

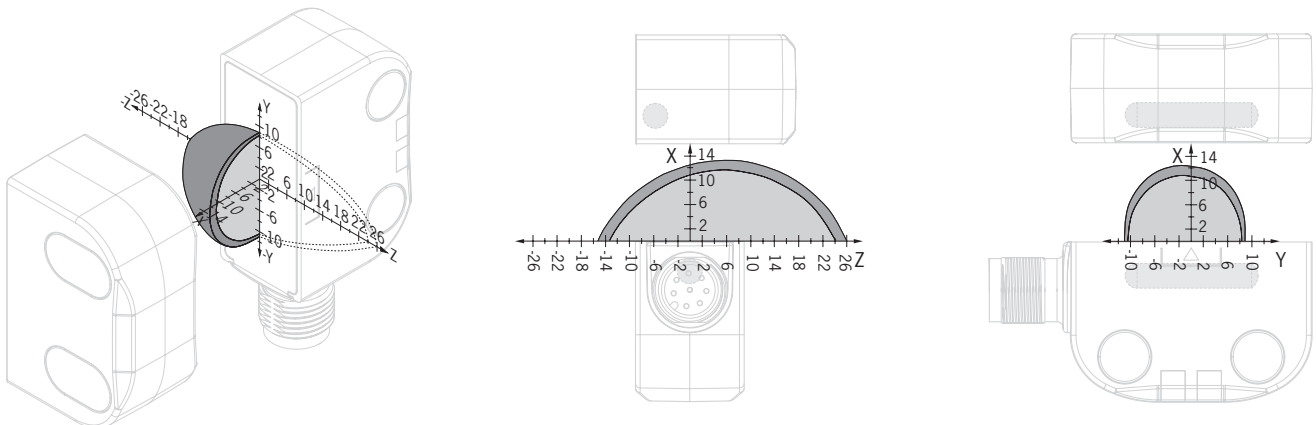

#### Operating distances for approach from x direction without center offset ( $z, y = 0$ )\*

Parameter	Value			Unit
	min.	typ.	max.	
Operating distances	-	13	-	mm
Assured operating distances $s_{ao}$	9	-	-	
Switching hysteresis <sup>1)</sup>	1	2	-	
Assured release distance $s_{ar}$	-	-	20	

\* The data apply to mounting the actuator on a non-metallic substrate. Depending on the substrate material, the actuating range may change.

**Typical actuating range in installation position C**

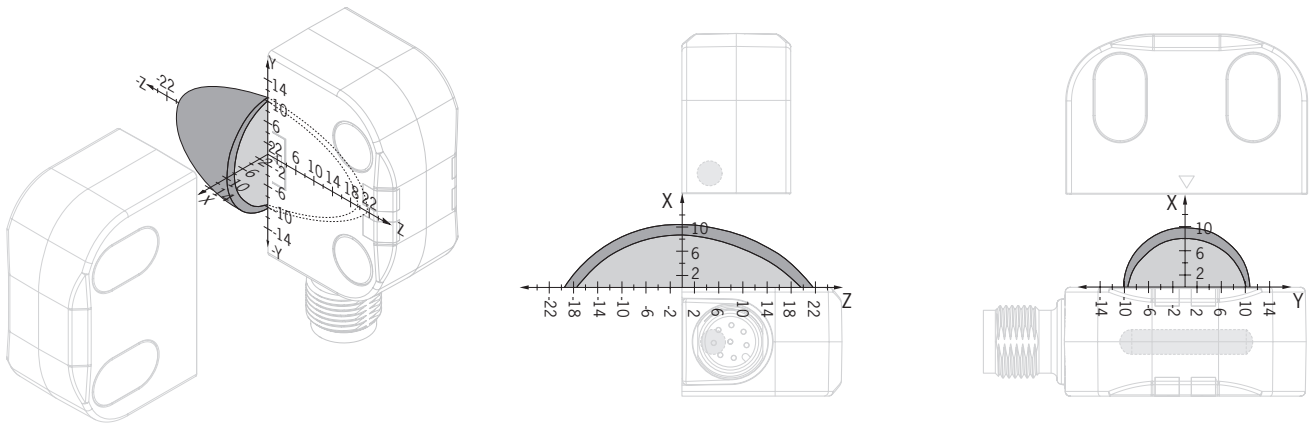

**Operating distances for approach from x direction without center offset (z, y = 0)\***

Parameter	Value			Unit
	min.	typ.	max.	
Operating distances	-	7	-	mm
Assured operating distances $s_{a0}$	3	-	-	
Switching hysteresis <sup>1)</sup>	1	2	-	
Assured release distance $s_{ar}$	-	-	17	

\* The data apply to mounting the actuator on a non-metallic substrate. Depending on the substrate material, the actuating range may change.

**Typical actuating range in installation position D**

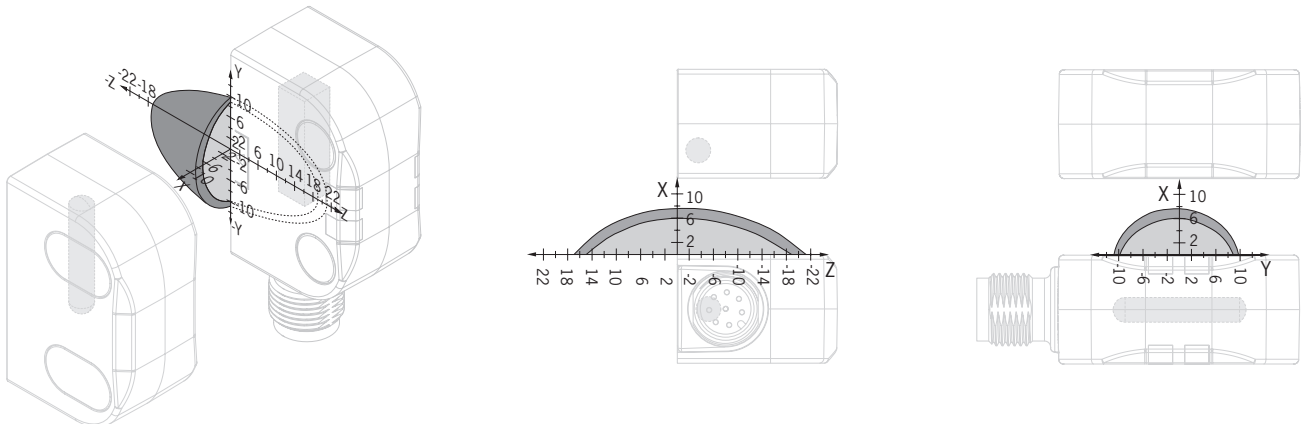

**Operating distances for approach from x direction without center offset (z, y = 0)\***

Parameter	Value			Unit
	min.	typ.	max.	
Operating distances	-	7	-	mm
Assured operating distances $s_{a0}$	2	-	-	
Switching hysteresis <sup>1)</sup>	1	2	-	
Assured release distance $s_{ar}$	-	-	17	

\* The data apply to mounting the actuator on a non-metallic substrate. Depending on the substrate material, the actuating range may change.

### 13.3. Technical data for actuator CES-A-BDN-06-158210

Parameter	Value			Unit
	min.	typ.	max.	
Housing material	Macromelt PA-based plastic			
Dimensions	26 x Ø 6			mm
Weight	0.005			kg
Ambient temperature	- 40	-	+ 65	°C
Degree of protection	IP65/IP67/IP69/IP69K 1)			
Installation orientation	Active face opposite switch			
Power supply	Inductive via switch			

1) With flush installation

#### 13.3.1. Dimension drawing

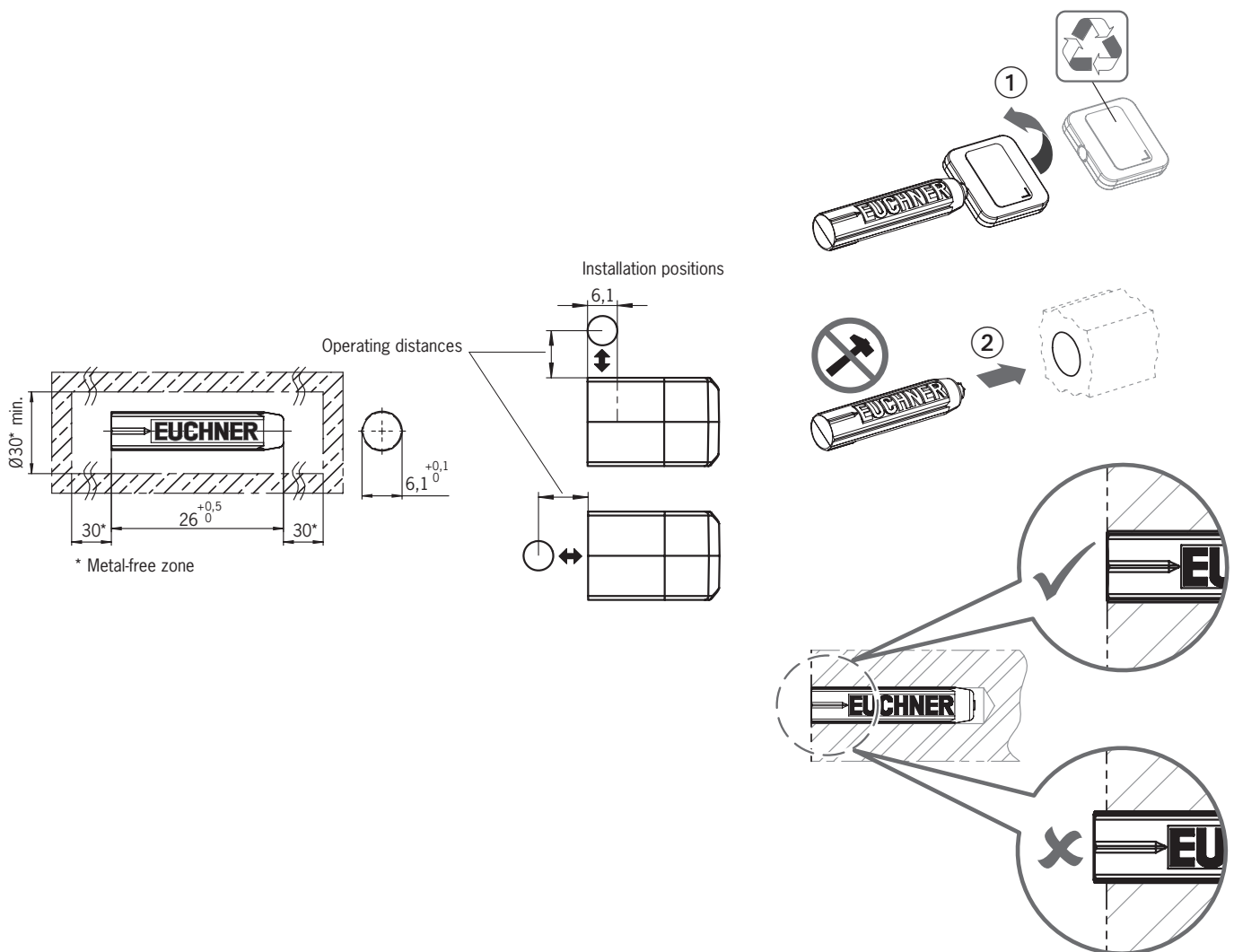

#### CAUTION

- › Do not mount at temperatures below 0 °C.
- › The actuator can be damaged during mounting.

13.3.2. Operating distances\*

Actuating range for center offset  $m = 0$

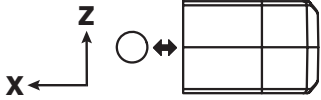
Installation position	Parameter	Value			Unit
		min.	typ.	max.	
<b>A</b>		min.	typ.	max.	
	Operating distances	-	16	-	mm
	Assured operating distances $s_{a0}$	13	-	-	
	Switching hysteresis	1	2	-	
	Assured release distance $s_{ar}$ - in x direction	-	-	24	

\* The data apply to mounting the actuator in non-metallic surroundings.

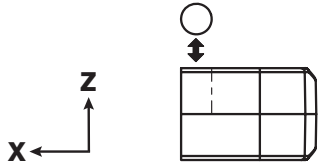
Installation position	Parameter	Value			Unit
		min.	typ.	max.	
<b>C</b>		min.	typ.	max.	
	Operating distances	-	11	-	mm
	Assured operating distances $s_{a0}$	6	-	-	
	Switching hysteresis	1	2	-	
	Assured release distance $s_{ar}$ - in z direction	-	-	21	

\* The data apply to mounting the actuator in non-metallic surroundings.

## 14. Ordering information and accessories



### Tip!

Suitable accessories, e.g. cables or assembly material, can be found at [www.euchner.com](http://www.euchner.com). To order, enter the order number of your item in the search box and open the item view. Accessories that can be combined with the item are listed in *Accessories*.

## 15. Inspection and service



### WARNING

Loss of the safety function because of damage to the device.

- › In case of damage, the entire device must be replaced.
- › Only accessories or spare parts that can be ordered from EUCHNER may be replaced.

Regular inspection of the following is necessary to ensure trouble-free long-term operation:

- › Check the switching function (see chapter 10.2. *Electrical function test on page 17*)
- › Check the secure mounting of the devices and the connections
- › Check for contamination

No servicing is required. Repairs to the device are only allowed to be made by the manufacturer.



### NOTICE

The year of manufacture can be seen in the bottom right corner. The current version number in the format (VX.X.X) can also be found on the device.

## 16. Service

If servicing is required, please contact:

EUCHNER GmbH + Co. KG  
Kohlhammerstraße 16  
70771 Leinfelden-Echterdingen  
Germany

### Service telephone:

+49 711 7597-500

### E-mail:

[support@euchner.de](mailto:support@euchner.de)

### Internet:

[www.euchner.com](http://www.euchner.com)

## 17. Declaration of conformity

The declaration of conformity is part of the operating instructions.

The complete EU declaration of conformity can also be found at [www.euchner.com](http://www.euchner.com). Enter the order number of your device in the search box. The document is available under *Downloads*.





EUCHNER GmbH + Co. KG  
Kohlhammerstraße 16  
70771 Leinfelden-Echterdingen  
Germany  
info@euchner.de  
www.euchner.com

Edition:  
2528734-04-12/22  
Title:  
Operating instructions Non-Contact Safety Switch  
CES-IBP.-C07-...  
(translation of the original operating instructions)  
Copyright:  
© EUCHNER GmbH + Co. KG, 12/2022

Subject to technical modifications; no responsibility is accepted for the accuracy of this information.