

Maße in mm / Dimensions in mm
© EUCHNER GmbH + Co. KG
no responsibility is accepted for the accuracy of this information.
Technische Änderungen vorbehalten, alle Angaben ohne Gewähr / Subject to technical modifications:

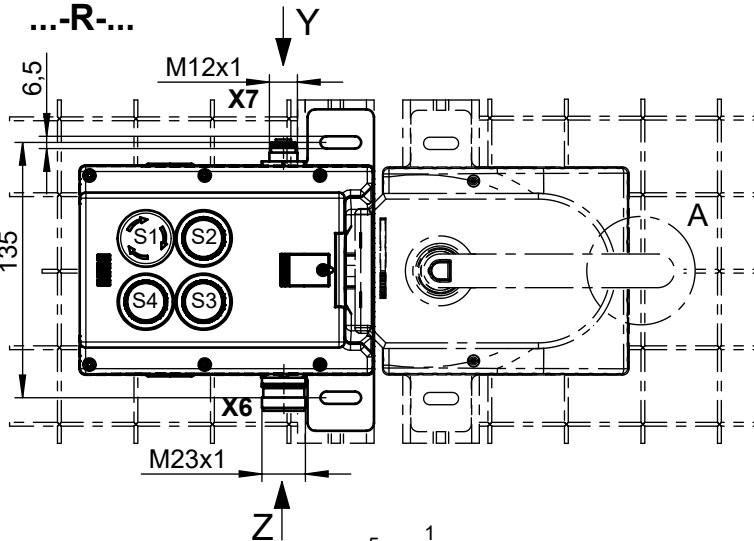

X7 SFF5 (M12) (Buchse/female)
Ansicht Steckseite Y
View plug connection side Y
Einbaustecker nicht ausgerichtet /
Connector not aligned

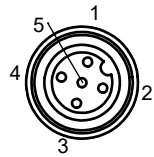

X6 RC18 (Stift/male)
Ansicht Steckseite Z
View plug connection side Z
Einbaustecker nicht ausgerichtet /
Connector not aligned

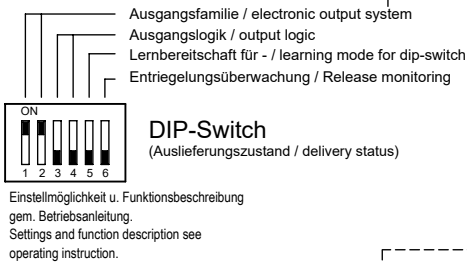
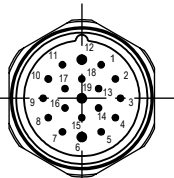

Belegung Deckeltaster:
PIN assignment top cover button:

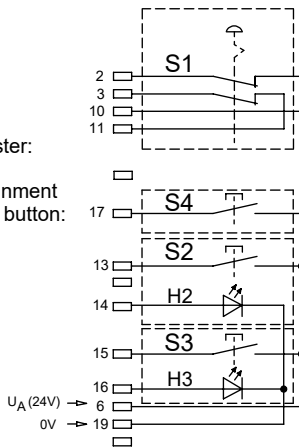

Achtung:
Im Auslieferungszustand sind IMP1 u. IMP2 mit einem Jumper gebrückt.
Eine 2-kanalige Ansteuerung des Magnets ist bei diesem Gerät nicht vorgesehen.
Attention:
In the default setting IMP1 and IMP2 are connected with a jumper.
Dual channel solenoid activation is not intended for this MGB.

Betriebsanleitung beachten
(bei Abweichungen zwischen Datenblatt u. Betriebsanleitung gelten die Daten des Datenblattes)
Please observe the operating instructions (in case of disagreement between data sheet and operating instructions, the information of the data sheet are to be considered)

Detail A
Sperrverriegelung im ausgefahrenen Zustand
Automatic lockoutbar in "open" position.

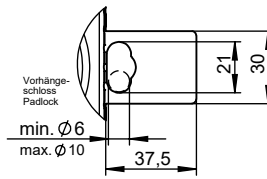

X7 Belegung (PIN assignment)

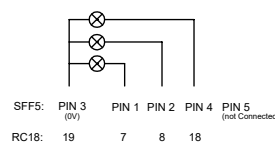

...-L-...

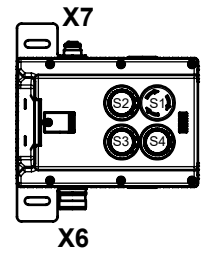

Blenden-Set für Taster inklusive:
Lens-Set for button including:
2x weiss / white
2x blau / blue
2x gelb / yellow
2x grün / green

	MGB-H	MGB-L..	MGB-E..	Türanschlag Door hinge	S1	S2	S3	S4
MGB-L1-APA-AP5A2-S10-R-173061		X		R	NOT-HALT Taster Emergency stop	Taster beleuchtet Button illuminated	Taster unbeleuchtet Button non illuminated	
MGB-L1HE-APA-R-173351	X	X	X					
MGB-L1-APA-AP5A2-S10-L-173062		X		L				
MGB-L1HE-APA-L-173353	X	X	X					

RC 18 PIN	Bezeichnung Designation	Beschreibung	Description
1	IMP1 (IMP2)	Steuerspannung zum Ein- und Ausschalten der Zuhaltung, DC 24V. Anschluss gem. Betriebsanleitung. (Bei MGB-L0, nicht belegt)	Control voltage for switching on and off the guard locking, DC 24V. Connection acc. to operating instructions. (Not used by MGB-L0)
2	S1.A1	NOT-HALT (Kanal A)	Emergency stop (circuit A)
3	S1.B1	NOT-HALT (Kanal B)	Emergency stop (circuit B)
4	FO1A	Sicherheitsausgang Kanal A, AN wenn Tür geschlossen u. zugehalten / verriegelt ist. Achtung: Stellung des DIP-Switch beachten	Safety output channel A, ON when door closed and guard locked / interlocked. Attention: Position of the DIP-Switch settings has to be observed.
5	FO1B	Sicherheitsausgang Kanal B, AN wenn Tür geschlossen und zugehalten / verriegelt ist. Achtung: Stellung des DIP-Switch beachten	Safety output channel B, ON when door is closed and guard locked / interlocked. Attention: Position of the DIP-Switch settings has to be observed.
6	UA UB	Spannungsversorgung für Zuhaltmagnet (L1/L2), Meldeausgänge u. Taster, DC 24V muss permanent anliegen.	Power supply for the interlocking solenoid, (L1/L2) monitoring output and button, DC 24V must be present continuously.
7	-	Stacklight	Stacklight
8	-	Stacklight	Stacklight
9	OI	Meldeausgang DIA, AN wenn das Gerät im Fehlerzustand ist.	Monitoring output DIA, ON when the device is in the fault state.
10	S1.A2	NOT-HALT (Kanal A)	Emergency stop (circuit A)
11	S1.B2	NOT-HALT (Kanal B)	Emergency stop (circuit B)
12	⊕	Steckerverbindergehäuse	Connector housing
13	S2	Taster beleuchtet	Button illuminated
14	H2	LED 2	
15	S3	Taster beleuchtet	Button illuminated
16	H3	LED 3	
17	S4	Taster unbeleuchtet	Button non illuminated
18	-	Stacklight	Stacklight
19	0V	Masse für Spannungsversorgung UA / UB.	Ground for the power supply UA / UB.