

Enabling Switches ZS



EUCHNER

More than safety.

EUCHNER

More than safety.



Headquarters in Leinfelden-Echterdingen



Logistics center in Leinfelden-Echterdingen



Production location in Unterböhringen

Internationally successful – the EUCHNER company

EUCHNER GmbH + Co. KG is a world-leading company in the area of industrial safety technology. EUCHNER has been developing and producing high-quality switching systems for mechanical and systems engineering for more than 60 years.

The medium-sized family-operated company based in Leinfelden, Germany, employs around 800 people around the world.

18 subsidiaries and other sales partners in Germany and abroad work for our international success on the market.

Quality and innovation – the EUCHNER products

A look into the past shows EUCHNER to be a company with a great inventive spirit. We take the technological and ecological challenges of the future as an incentive for extraordinary product developments.

EUCHNER safety switches monitor safety doors on machines and installations, help to minimize dangers and risks and thereby reliably protect people and processes. Today, our products range from electromechanical and electronic components to intelligent integrated safety solutions. Safety for people, machines and products is one of our dominant themes.

We define future safety technology with the highest quality standards and reliable technology. Extraordinary solutions ensure the great satisfaction of our customers.

The product ranges are subdivided as follows:

- ▶ Transponder-coded Safety Switches
- ▶ Transponder-coded Safety Switches with guard locking
- ▶ Multifunctional Gate Box MGB
- ▶ Access management systems (Electronic-Key-System EKS)
- ▶ Electromechanical Safety Switches
- ▶ Magnetically coded Safety Switches
- ▶ Enabling Switches
- ▶ Safety Relays
- ▶ Emergency Stop Devices
- ▶ Hand-Held Pendant Stations and Handwheels
- ▶ Safety Switches with AS-Interface
- ▶ Joystick Switches
- ▶ Position Switches

 **made
in
Germany**

Enabling Switches

General	4
About this catalog	4
Standards and approvals	5
Function and technology used in enabling switches	5
Built-in enabling switch ZSE/ZXE	9
Enabling switch ZSM	13
Enabling switch ZSA/ZSB/ZSR	33
Enabling switch ZSA (housing G1)	34
Enabling switch ZSB with additional pushbuttons and LEDs (housing G1)	38
Enabling switch ZSR (housing G2)	42
Enabling switch ZSB with additional pushbuttons and LEDs (housing G3)	43
Enabling devices ZSG/ZSA	49
Built-in enabling device ZSG	50
Enabling devices ZSA (housing G1)	51
Kits	53
Kit for enabling switch ZSM	54
Kit for enabling switch ZSA (housing G1)	60
Kit for enabling device ZSA (housing G1)	61
Accessories	63
Holders and components	64
Plug connectors and cables	66
Technical data	71
Wiring diagrams for enabling switch ZSM	72
Technical data for enabling switch ZSM	80
Technical data for enabling switch ZSE/ZXE/ZSA/ZSB/ZSR	82
Technical data for accessories for enabling switches	84
Item Index	86
Index by item designation	86
Index by order number	88





About this catalog



The Enabling Switch ZS catalog provides an overview of our two-stage enabling devices and three-stage enabling switches. Due to their robust and ergonomic design, these switches are the right choice for numerous applications.

You will find the technical data after the product overview. There is a reference to the page with the related technical data on the pages listing the products.

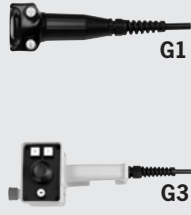
At the front of the catalog, you will find useful information on the topic of enabling switches.

You will find the following series and accessories in this catalog:

3-stage enabling switches					
Enabling switches for installation	Hand-held enabling switches				Accessories
ZSE and ZXE	in housing ZSM or as kit	in housing G1 or as kit	in housing G1, G3	in housing G2	Cables, plug connectors, holders, blanking covers
 <p>ZSE</p> <p>ZXE</p>	 <p>ZSM</p>	 <p>ZSA</p> <p>G1</p>	 <p>ZSB</p> <p>G1</p> <p>ZG3</p>	 <p>ZSR</p> <p>G2</p>	

2-stage enabling devices	
Enabling devices for installation	Hand-held enabling devices
<p>ZSG</p>  <p>ZSG</p>	<p>in housing G1 or as kit</p> <p>ZSA</p>  <p>G1</p>

Standards and approvals

Standards

Enabling switches that are integrated into safety circuits have a safety function. For this reason, they are assessed based on the Machinery Directive and the European standards. The Machinery Directive has been implemented in national law in the EU member states and, as a result, is binding for all manufacturers.

Detailed requirements for switches are defined in EN 60947 Part 5-1 (Low-voltage switchgear and controlgear – Part 5-1: Control circuit devices and switching elements – Electromechanical control circuit devices).

If the requirements of these standards are met, conformity with the applicable laws and therefore with the Machinery Directive is assumed. EUCHNER enabling switches comply with the relevant standards for safety switchgear and thereby help you to comply with safety requirements during the design of your machinery.

User standards

As a user, you should take into consideration the following standards of relevance for enabling switches:

European and international standards

Standard	Title
EN 60 204	Safety of machinery – Electrical equipment of machines
EN 775/ EN ISO 10218	Robotics – Safety requirements for robot systems in an industrial environment (ISO 10218:1992, modified)
VDI 2853	Safety requirements for construction, equipment and operation of industrial robots (withdrawn)
VDI 2854	Safety requirements for automated flexible manufacturing systems

American standards

Standard	Title
ANSI B11-TR3-2000	Risk Assessment and Risk Reduction – A Guide to Estimate, Evaluate and Reduce Risks Associated with Machine Tools
NFPA 79 (2002)	Electrical Standard for Industrial Machinery
OSHA 29 CFR 1910	
Subpart O	Machinery and Machine Guarding
Subpart P	Hand and Portable Power Tools and Other Hand-Held Equipment
Subpart S	Electrical

Please also observe any existing C standards.

Approvals

To demonstrate conformity, the Machinery Directive also includes the possibility of type examination. In addition to taking into account all relevant standards, EUCHNER commissions type examinations by a notified body. Many of the enabling switches listed in this catalog have been tested by an employers' liability insurance association (BG) and are given in the lists from the BG.

Furthermore, many enabling switches are listed by Underwriters Laboratories (UL) and the Canadian Standards Association (CSA). These enabling switches can be used in countries in which this listing is required. The approval symbols on the individual pages of the catalog indicate which body tested the enabling switches.

With the aid of the approval symbols listed below, you can quickly see which approvals are available for the related enabling switches:

	Switches with this symbol have the approval of the German Social Accident Insurance Association (DGUV) – formerly the employers' liability insurance association (BG)
	Switches with this symbol are approved by Underwriters Laboratories (UL, Canada and USA)

Function and technology used in enabling switches

Task of enabling switches

Enabling switches are manually operated control devices that, together with other command switches, enable commands related to potentially hazardous conditions to be run as long as the enabling switches are actuated continuously.

These switches are used wherever operating personnel must work directly in the danger zone on machines and installations. This is necessary during setup, programming, testing or servicing work, for example. As per Annex 1 of the Machinery Directive, the protective action of movable guards can be disabled in these operating modes. The Machinery Directive places the condition that these operating modes must be secured using a lockable device (e.g. key-operated rotary switch) and machine operation is allowed to be triggered only by a second, separate action.

To enable the operator in the danger zone of a machine to activate a machine movement, an enabling device must additionally be actuated. The operator must also be able to stop the machine movement using the enabling device. This task is performed by the enabling switch.

Every person who is in the hazardous area must carry an enabling device so that suitable action can be taken in case of danger.

Two-stage enabling device or three-stage enabling switch?

The operator can start a machine movement only if he/she actuates the enabling device and keeps it in the actuated position. The movement is stopped again when the switch is released. This two-stage function (OFF-ON) is provided by all enabling switches.

However, experience shows that the operator often clenches the enabling device in an emergency.

In this case, a three-stage enabling switch is better and is specifically requested in many C standards. This switch has three switch positions (OFF-ON-OFF) and, if the operator clenches the switch, it is actuated beyond the enabling position (center position) and the machine is shut down as a result.

If a 2-stage enabling device is used, it must also be ensured that, in an emergency, the operator is in a position to activate an emergency stop device in close proximity (VDI 2853). The following symbols are used to identify the type of enabling switch in the catalog:

Symbol for a 2-stage enabling device	Symbol for a 3-stage enabling switch

Large selection of switching elements

To be able to cover as many applications as possible, EUCHNER enabling switches can be fitted with various switching elements of single-channel or dual-channel design. Monitoring contacts are also available, as are additional devices or displays.

Positively driven contacts

Positively driven contacts are used in many switching elements. These are special switching contacts that are designed to ensure that the switching contacts are always reliably separated. Even if contacts are welded together, the connection is opened by the actuating force.

Function sequence of two-stage enabling device

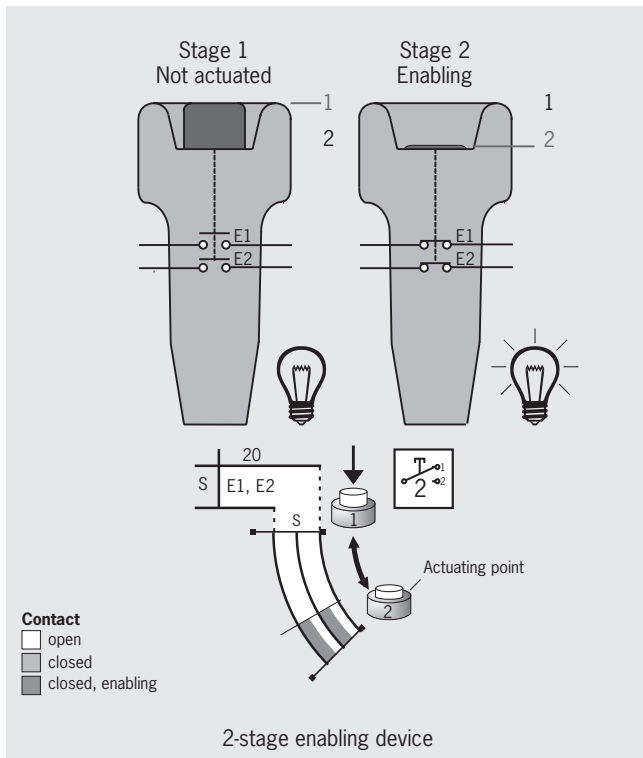

Function sequence of three-stage enabling switch

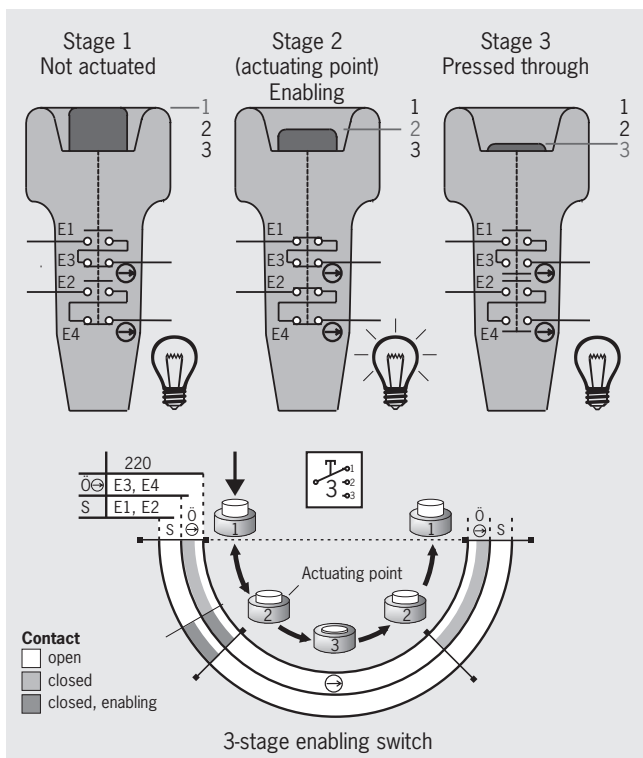

As can be clearly seen in the figure, the enabling function can be achieved only in stage 2. This function is provided by the closing of the normally open contacts (NO = E1 and E2). If the button is released, that is back from stage 2 to stage 1, the normally open contacts are opened again. The 2-stage enabling devices and 3-stage enabling switches are identical in this function.

If, as in this example, the button on a 3-stage enabling switch is pressed past the actuating point (stage 2) in panic (to stage 3), this not only resets the normally open contacts (NO) but additionally opens the safe positively driven contacts (NC ⊖).

The patented switching system ensures that the enabling function does not become active in stage 2 on reset of the pushbutton from stage 3 to stage 1. In this example, enabling is possible only if normally open and positively driven contacts are closed at the same time. This situation is possible only on actuation from stage 1 to stage 2. In the other direction, from stage 3 to stage 1, stage 2 is skipped and unintentional restarting prevented. Once the pushbutton has reached stage 1, the function sequence can be started again.

Due to its design, the switching unit also provides a wear-free, constant actuating point (stage 2).

Reading travel diagrams and wiring diagrams

For each of the switching elements used, there is a travel diagram that, depending on the enabling switch's switching stage, shows the switching states.

The following example is intended to explain these aspects:

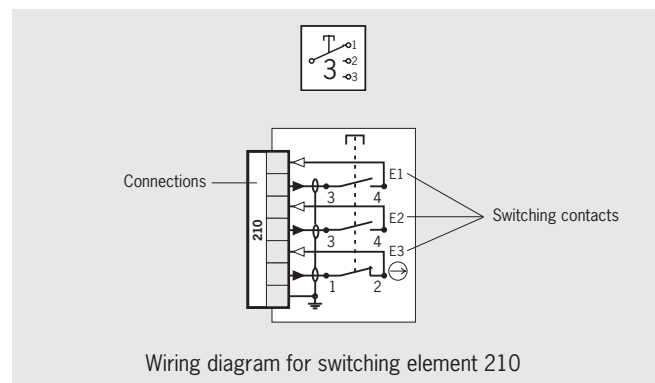

The wiring diagram shows the switching element in the free position (enabling switch not actuated).

The switching element 210 has three switching contacts (E1, E2 and E3). The switching contact E3 is designed as a positively driven contact, the other two switching contacts as normally open contacts.

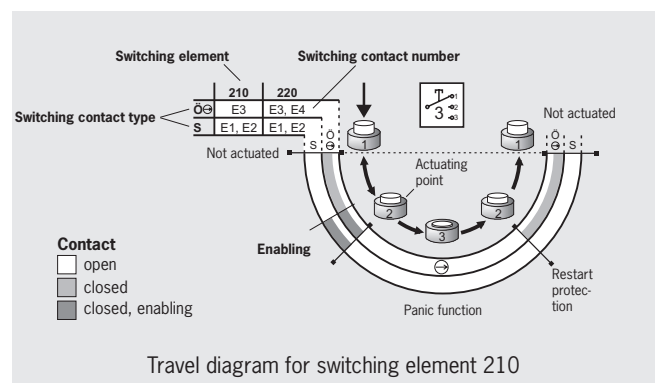

As in this example, several switching elements are combined in one travel diagram in some cases. Here, along with the switching element 210 with the switching contacts E1, E2 and E3, there is also the switching element 220 with the switching contacts E1 to E4.

The letters on the left beside the switching contact E3 define the switching contact type, a positively driven contact (NC ⊖) in this case.

The following switching contact types are available:

- ▶ NO normally open contact
- ▶ NC normally closed contact
- ▶ NC ⊖ positively driven contact
- ▶ NO/NC three-point switch
(3-stage switching contact with normally open/normally closed function; switching stage dependent on the actuating travel)
- ▶ NO/NC ⊖ three-point switch
(like NO/NC but with positively driven contact)

The travel diagram shows the switching state of each switching contact for the three switch stages “Not actuated,” “Enabling” and “Panic function” (pressed past actuating point). Gray areas mean “switch closed”; white areas mean “switch open.”

In the example for switching element 210, the sequence is as follows:

- ▶ In the not actuated state, the positively driven contact E3 is closed (gray area) and the two normally open contacts E1 and E2 are open.
- ▶ When the switch has reached stage 2, the normally open contacts E1 and E2 are closed, E3 remains closed. This is the enabling area.
- ▶ If the switch is released, the switching contacts return to their initial state.
- ▶ If the switch is pressed beyond the enabling area, all switching contacts are opened. This is the “panic function” area on the travel diagram.
- ▶ If the switch is now released again, the positively driven contact E3 is closed again. The switching system prevents the normally open contacts E1 and E2 from closing again at the same time (restart protection).

An optimal sequence is provided by the series connection of E1 (normally open contact) and E3 (positively driven contact), as then enabling is possible only at the actuating point. On pressing through to stage 3, the safe positively driven contact opens the safety circuit. On this switching element, E2 can be used as a monitoring contact or a 2nd channel.

Single-channel and dual-channel enabling switches

Often, two positively driven contacts and normally open contacts are employed to increase safety using the principle of duplicated design (redundancy). This dual-channel design ensures that on the failure of one channel or on a fault in the control circuit (e.g. in the machine wiring), the safety function can still be provided with the aid of the second channel. An example is given in the wiring diagram for switching element 220:

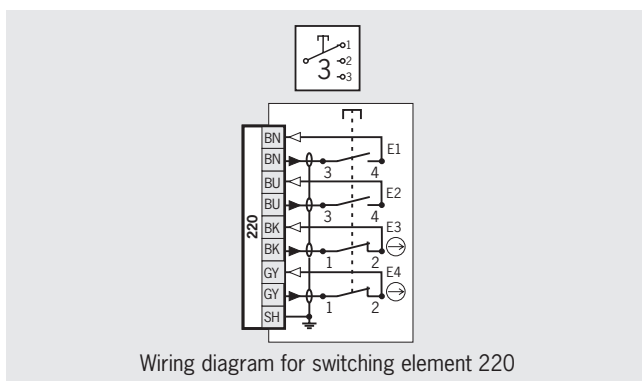

The normally open contact E1 and the positively driven contact E3 as well as the normally open contact E2 and the positively driven contact E4 can be connected externally in series. In this way, a dual-channel design is achieved.

Safety in case of faults

Along with the possibility of using positively driven contacts and the possible dual-channel layout of the design, the patented connecting cables from EUCHNER provide additional protection on the occurrence of faults. Not only the outer shielding of the cable but also the individual shielding of the cores enables short circuits or cable breaks due to crushing, for example, to be detected by a control system.

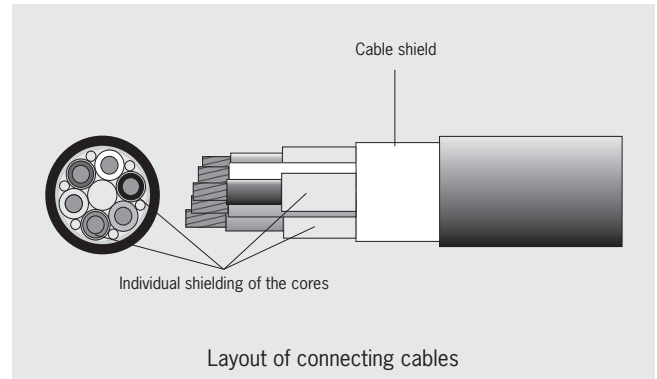

Protection against tampering

An enabling switch can ensure that operation is free of hazards only if it is not bypassed. To prevent tampering, our enabling switches are designed such that it is more difficult to bypass the safety function. The best protection against tampering is, however, acceptance by the user.

Ergonomics

To achieve the related user acceptance of a manually operated control device, the focus of EUCHNER enabling switches is on safe and balanced handling, even over extended periods (e.g. when observing manufacturing processes). Enabling switches manufactured by EUCHNER have a low weight, an ergonomic housing design and a light, stable actuating point. Both thumb-actuated switches and switches that can be actuated with several fingers in order to maintain the actuating force over an extended period are used.

By selecting a coiled cable with long cable ends, the weight of the switch is reduced as the heavy, spiral part of the cable lies on the floor and only the lighter, straight part needs to be held by the user.



Enabling switches for installation

The enabling devices in series ZSG and the enabling switches in series ZSE and ZXE can be integrated into any housings or control panels. As a result, every customer can prepare a customized solution to suit his/her specific application.



Kits for enabling switches

Using enabling switch kits from EUCHNER, you can assemble your own customized enabling switch ideally matched to your requirements. The kit is available for the housing G1 as a two- or three-stage version and for the ZSM as a three-stage version. Various switching elements are available.

Hand-held enabling switches

The enabling switches in the series ZSM, ZSA, ZSB and ZSR are installed in a housing and are already pre-wired. Depending on version, the hand-held enabling switches feature a degree of protection up to IP67 (see chapter *Technical data* page 80 ff.). In addition to providing the enabling function, EUCHNER enabling switches can be equipped with additional command buttons (pushbutton, selector switch, key-operated rotary switch or emergency stop device) and LED indicators. In this way, work processes such as axis selection and the movement of axes can be performed directly at the machine using the enabling switch.



Electrical connection

Different cable lengths and cable types are available for the connection of the pre-assembled hand-held enabling switches. Modern wiring concepts increasingly utilize plug-in connections. The enabling switch does not need to remain permanently connected, but is plugged in as required. Furthermore, a switch with plug connector can be easily replaced during servicing work. This configuration results in short downtimes. The enabling switches ZSM, ZSA, ZSB and ZSR are available with various plug connectors. In addition to the related mating connectors, further accessories are available.

Identification of switching elements

The switching elements used in our enabling switches have a numerical designation. A selection of switching elements is available depending on the series.

Explanation of symbols and notation

Symbols and specific notation related to the switch or the switching contact are used time and again in the catalog. The following example is intended to explain these aspects:

Notation

1 NC ⊖ + 1 NO

Explanation

Normally closed contacts are represented by NC, normally open contacts by NO. The number defines how many contacts are available. The symbol following the NC indicates that the NC contact is a positively driven contact. This switch therefore has one normally closed contact and one normally open contact; the normally closed contact is a positively driven contact.

Acknowledgment of enabling

Vibration signal

The enabling switch ZSM is optionally equipped with a vibration motor. This permits acknowledgment of enabling in a loud environment, for example. The signal pulsates, similar to the vibration signal of cellular telephones.



LED

An LED can also be optionally used as visual acknowledgment. Several products are equipped accordingly.

Emergency stop/machine stop

All emergency stop devices with red pushbutton must be active in the danger zone. Since a plugged connection could be unplugged in certain circumstances, enabling switches with plug connectors are equipped only with a gray machine stop. Otherwise, it must be ensured that confusion between effective and non-effective devices is ruled out.

Selection table for built-in enabling switches ZSE and ZXE

Design			
E	Built-in version (without cable)		
	Function		
	3	3-stage (OFF - enabling - OFF)	
		Connection	
		C	Tab connector, screw terminal
 Enabling switch ZXE	 Enabling switch ZSE		
Design E ●	Stages 3 ●	Connection C ●	Page 10 - 12



Built-in enabling switches ZSE and ZXE

- ▶ 3-stage function
- ▶ Dual-channel version
- ▶ Optionally with 22.5 mm or 30.5 mm installation dimension
- ▶ Suitable for installation in hand-held pendant stations HBL or housing G2 or G3, for example



3-stage function

Enabling function is active only in the second stage (center position, actuating point). If the pushbutton is released or pushed further (panic function), the enabling is removed (dependent on the wiring, see function sequence).

Hand-held pendant stations HBL

See catalog for hand-held pendant stations.

Switching elements (see also page 8)

- ▶ **111** 1 NO + 1 NC ⊕ + 1 NC
- ▶ **121** 1 NO + 2 NC ⊕ + 1 NC
- ▶ **210** 2 NO + 1 NC ⊕
- ▶ **220** 2 NO + 2 NC ⊕
- ▶ **2202** 2 NO/NC ¹⁾

ZSE, 3-stage function

Tab connector

Dimension drawings

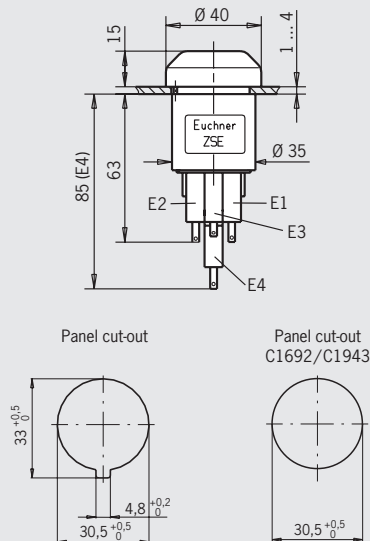

Wiring diagrams/function sequence

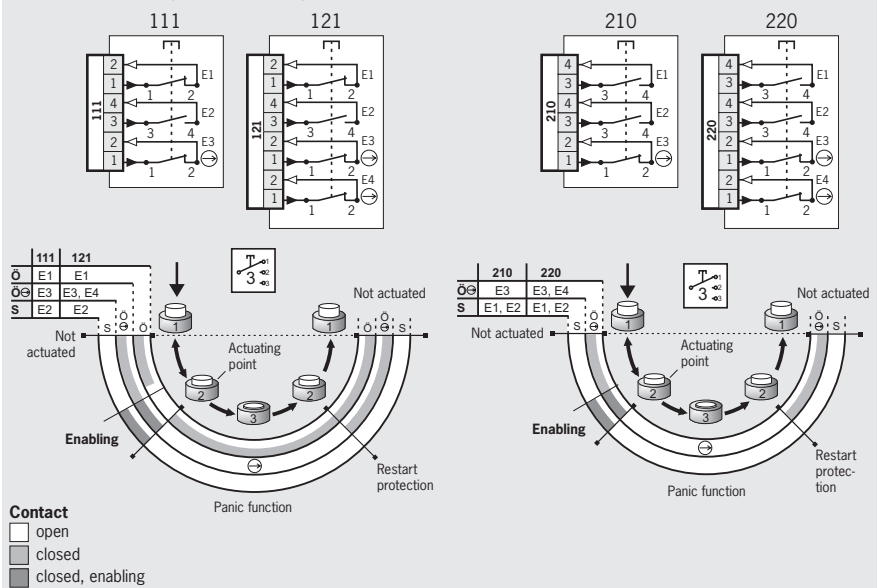

Ordering table

Design	Connection	Version	Switching element			
			111: 1NO+1NC ⊕ +1NC	121: 1NO+2NC ⊕ +1NC	210: 2NO+1NC ⊕	220: 2NO+2NC ⊕
Built-in 3-stage ZSE	Tab connector		052448 ZSE2-1	070782 ZSE2-3	052449 ZSE2-2	070762 ZSE2-4
		Suitable for hand-held pendant stations HBL, for example	On request	On request	070752 ZSE2-2C1692	083477 ZSE2-4C1943

ZSE, 3-stage function

Tab connection, with spacer

Dimension drawings

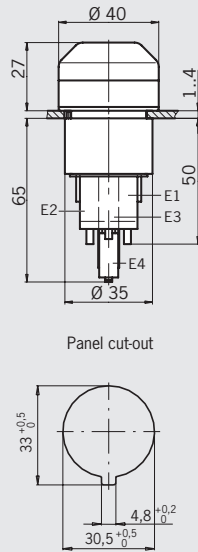

Wiring diagrams/function sequence

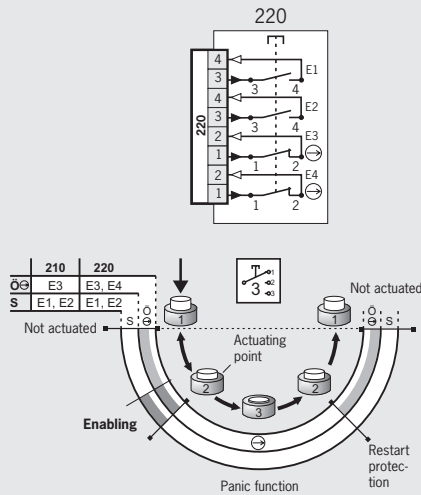

Contact
 open
 closed
 closed, enabling

Ordering table

Design	Connection	Version	Switching element			
			111: 1NO+1NC \ominus +1NC	121: 1NO+2NC \ominus +1NC	210: 2NO+1NC \ominus	220: 2NO+2NC \ominus
Built-in 3-stage ZSE	Tab connector	With spacer for installation in housing G2 or G3	On request	On request	On request	091098 ZSE2-4C1801



ZXE, 3-stage function Screw terminals

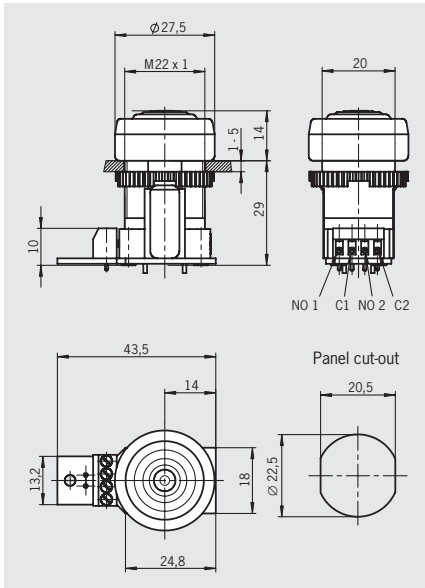

ZXE, 3-stage function Screw terminals, with click sound ¹⁾

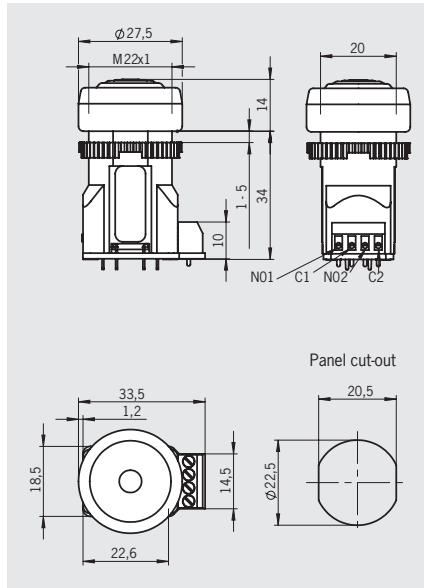

ZXE, 3-stage function Tab connectors, with click sound ¹⁾

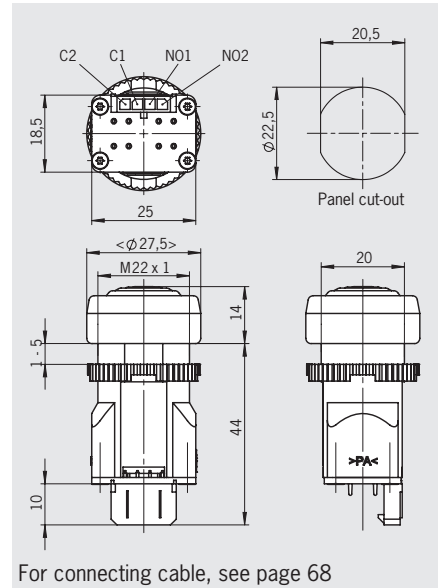

Wiring diagrams/function sequence

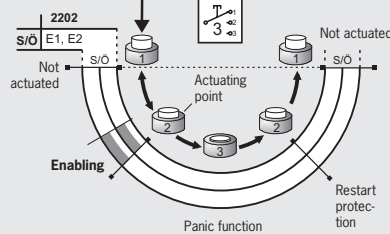
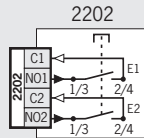

- Contact**
- open
 - closed
 - closed, enabling

Ordering table

Design	Connection	Version	Switching element
			2202: 2NO/NC ²⁾
Built-in 3-stage ZXE	Screw terminals	Slow-action switching contact	091336 ZXE-091336
		Snap-action switching contact	104833 ZXE-104833
	Tab connectors	Snap-action switching contact	111276 ZXE-111276

1) With versions ZXE-104833 and ZXE-111276, a click sounds during the change from stage 1 to stage 2 and during the return from stage 2 to stage 1.

2) From position 1 to position 2 ⇒ NO contact; from position 2 to position 3 ⇒ NC contact.

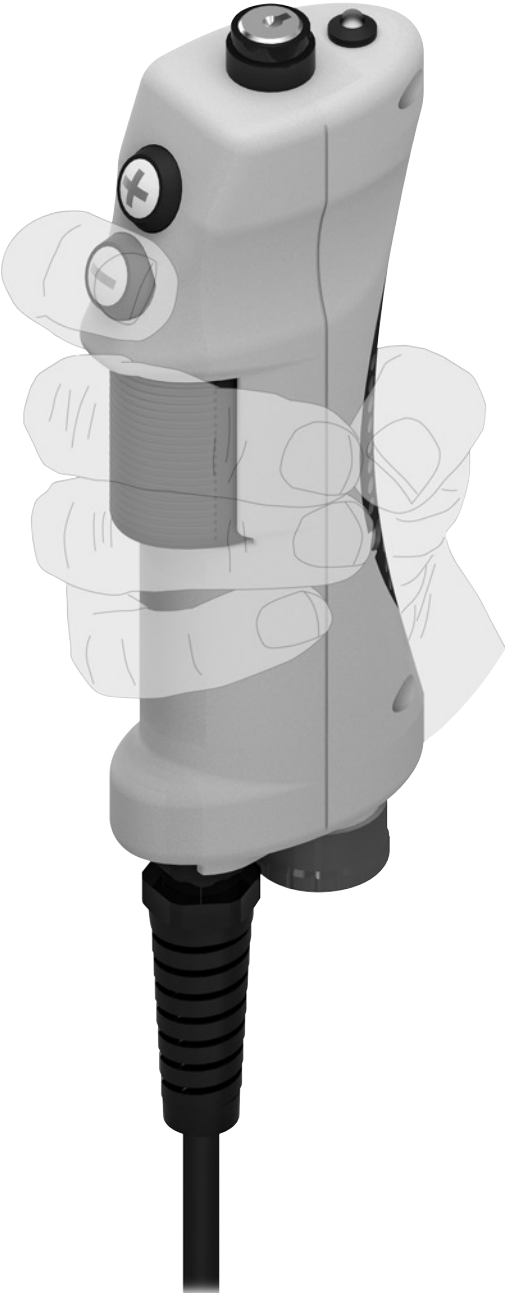

Item overview for enabling switch ZSM

Order no./item	Top		Stop command device		Front		Bottom		ZS	Vibration signal	Cable length [m]		Plug connector	Page
	Selector switch	Key-operated rotary switch	Pushbutton	LED indicator	Machine stop gray 2 NC ⊕	Emergency stop red 2 NC ⊕	Top pushbutton	Bottom pushbutton			Mini joystick	Key-operated rotary switch		
102966 ZSM4204-102966	-	-	-	●	-	White	-	-	3 C	●	5	-	-	16
105645 ZSM4204-105645	-	-	-	-	-	White	-	-	3 C	-	-	1.88-5	-	16
138119 ZSM2204-138119	-	-	-	●	⊕	⊕	-	-	1 NC + 2 NO	-	-	1.88-5	-	17
126706 ZSM2201-126706	-	-	-	-	⊕	⊕	-	-	2 NO	-	-	2.85-4.8	-	17
103126 ZSM2101-103126	-	●	-	●	⊕	⊕	-	●	3 NO	●	5	-	-	18
117128 ZSM2204-117128	-	-	Black	●	⊖	⊖	-	●	3 NO	●	10	-	-	18
123678 ZSM2104-123678	-	-	-	●	⊕	⊕	-	●	3 NO	-	5	-	RC12	19
110317 ZSM2301-110317	3-stage 1 of 3	-	-	●	⊕	⊕	-	-	2 NO	-	-	1.88-5	RC17	19
111595 ZSM2304-111595	3-stage 1 of 3	-	-	●	⊕	⊕	-	●	2 NO	-	-	1.88-5	RC17	19
105075 ZSM2301-105075	-	-	● Reset	●	⊖	⊖	-	●	2 NO	●	-	1.4-3.8	HAN Q17	20
099713 ZSM4200-099713	-	-	-	-	-	-	-	-	3 C	-	5	-	-	21
121883 ZSM4200-121883	-	-	-	-	-	-	-	-	3 C	-	-	3.1-9.8	-	21
111871 ZSM2300-111871	-	-	-	2 x ●	-	-	-	-	1 C + 1 NO	-	-	1.88-5	-	22
124156 ZSM4200-124156	-	-	-	-	-	Black	-	-	3 C	-	-	1.88-5	-	22
099714 ZSM2100-099714	-	-	-	●	-	⊕	-	-	3 NO	●	5	-	-	23
109971 ZSM2300-109971	-	-	-	●	-	⊕	-	-	2 NO	●	5	-	-	23
112803 ZSM2300-112803	-	-	-	●	-	⊕	-	-	2 NO	●	-	3-9	-	23
127990 ZSM2300-127990	-	-	-	●	-	⊕	-	-	2 NO	●	-	1.38-4.5	-	24
111462 ZSM2300-111462	-	-	-	●	-	⊕	-	-	2 NO	●	-	1.88-5	RC12	24
099716 ZSM2300-099716	-	-	-	-	-	⊕	-	-	2 NO	-	5	-	RC12	25

113290 ZSM2300-113290	-	-	-	-	-	-	-	-	-	-	-	13	-	RC12	25
100697 ZSM2200-100697	4-stage 1 of 4 Gray code	-	-	-	-	-	-	-	-	-	-	10	-	-	26
106103 ZSM2100-106103	5-stage Gray code	-	-	-	-	-	-	-	-	-	-	3	-	-	26
105308 ZSM2200-105308	12-stage Gray code	-	-	-	-	-	-	-	-	-	-	5	-	-	27
103462 ZSM3100-103462	12-stage Gray code	-	-	-	-	-	-	-	-	-	-	-	1.88 - 5	-	27
122279 ZSM2200-122279	16-stage Gray code	-	-	-	-	-	-	-	-	-	-	-	1.88 - 5	RC12	28
116714 ZSM2200-116714	-	-	-	-	-	-	-	-	-	-	-	12	-	-	29
110338 ZSM2300-110338	-	-	-	-	-	-	-	-	-	-	-	-	1.55 - 3.5	RC12	30
106670 ZSM2300-106670	-	-	-	-	-	-	Reset	-	-	-	-	-	1.25 - 3.1	HAN Q17	30
157209 ZSM2200-157209	-	-	-	-	-	-	Black	-	-	-	-	-	1.88 - 5	-	31
106374 ZSM2300-106374	-	-	-	-	-	-	Black	-	-	-	-	-	-	RC17	31

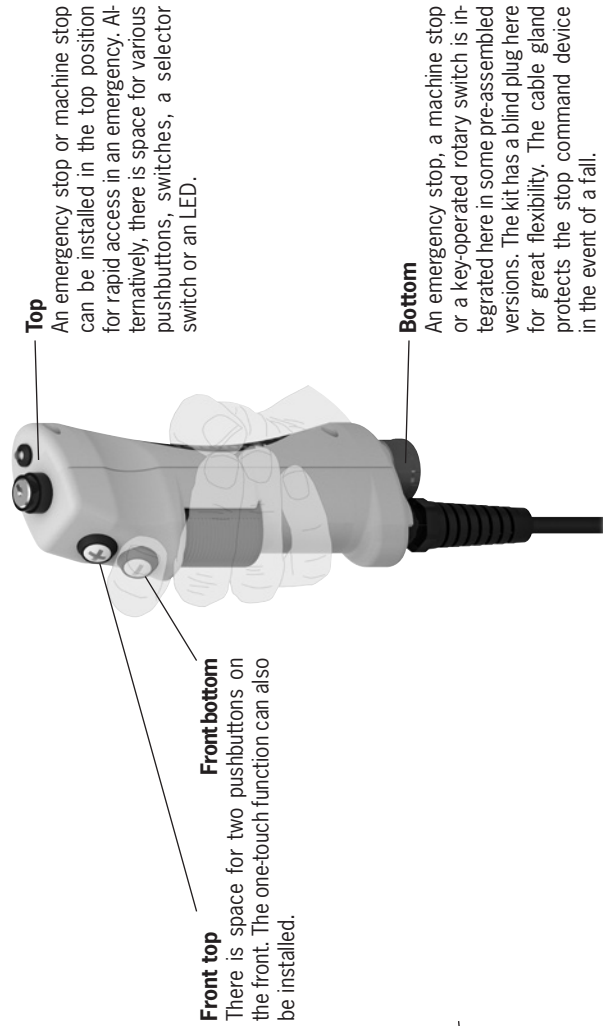

Enabling switch ZSM with upper stop command device



- ▶ 3-stage function
- ▶ Stop command device
- ▶ Vibration signal optional
- ▶ LED indicator optional
- ▶ Pushbutton
- ▶ Coiled connecting cable optional

3-stage function

Enabling function is active only in the second stage (center position, actuating point). If the pushbutton is released or pushed further (panic function), the enabling is removed (dependent on the wiring, see function sequence).

Stop command device

Dual-channel emergency stop device (red, with pull-to-reset and turn-to-reset button) or machine stop (gray, with pull-to-reset and turn-to-reset button) on the switch housing, for different wiring concepts.

Vibration signal

The vibration signal is used for tactile feedback of the enabling position.

LED indicator

The LED indicator is used for visual feedback directly at the enabling switch.

Pushbuttons

Additional functions can be run directly at the enabling switch using the pushbuttons.

+ and – buttons

These pushbuttons can be configured individually. For example, for moving axes in the positive or negative direction.

Cable

The high-quality connecting cables are available in a straight or coiled version.

ZSM4204-102966, 3-stage function

Flying lead, emergency stop device

Dimension drawing

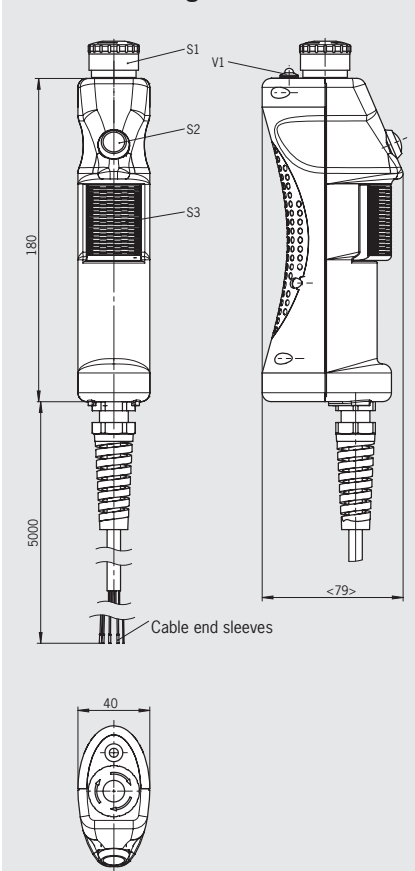

For wiring diagram, see page 72

ZSM4204-105645, 3-stage function

Flying lead, emergency stop device

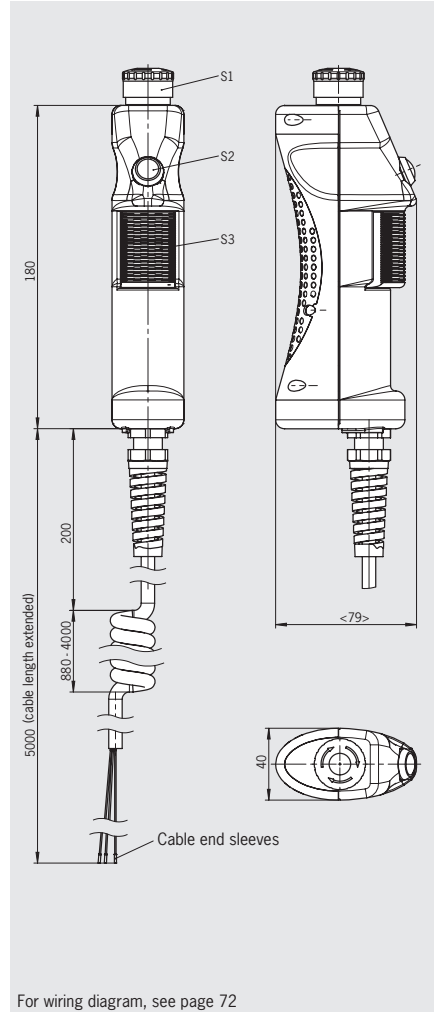

For wiring diagram, see page 72

Switching element/function sequence

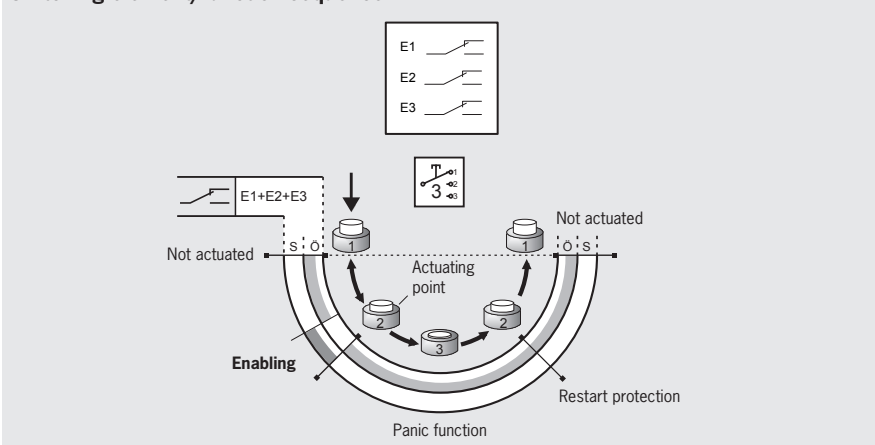

Ordering table

Design	Connection	Cable length	Version	Order no./item
ZSM	Flying lead 23 x 0.14 mm ²	5 m straight	Enabling switch with 3 changeover contacts (S3), red emergency stop device (S1), vibration signal, yellow LED indicator (V1), white pushbutton (S2)	102966 ZSM4204-102966
		1.88 ... 5 m coiled	Enabling switch with 3 changeover contacts (S3), red emergency stop device (S1), white pushbutton (S2)	105645 ZSM4204-105645



ZSM2204-138119, 3-stage function

Flying lead, emergency stop device

ZSM2201-126706, 3-stage function

Flying lead, machine stop

Dimension drawing

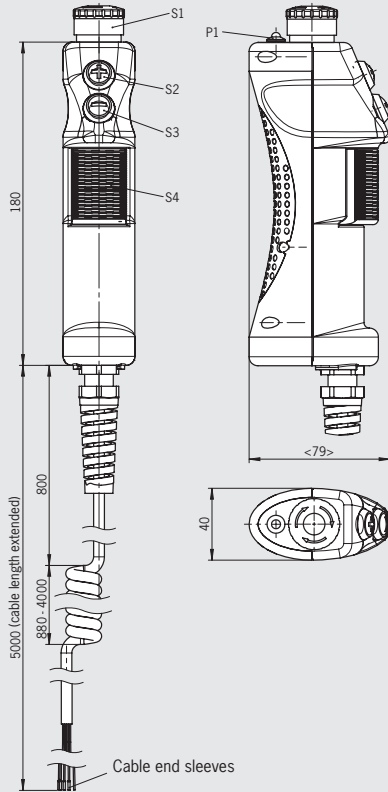

For wiring diagram, see page 72

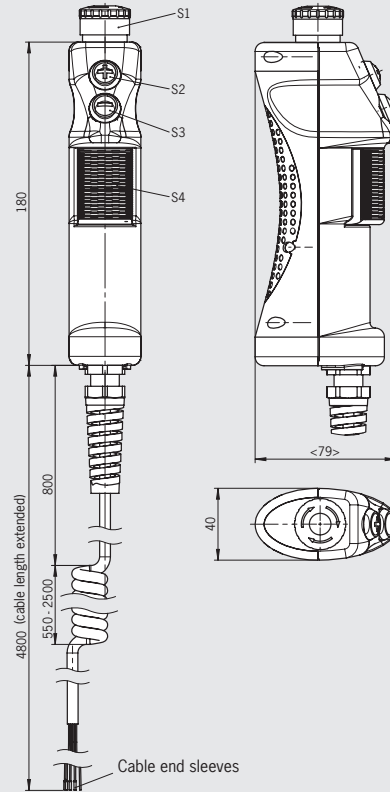

For wiring diagram, see page 72

Switching element/function sequence

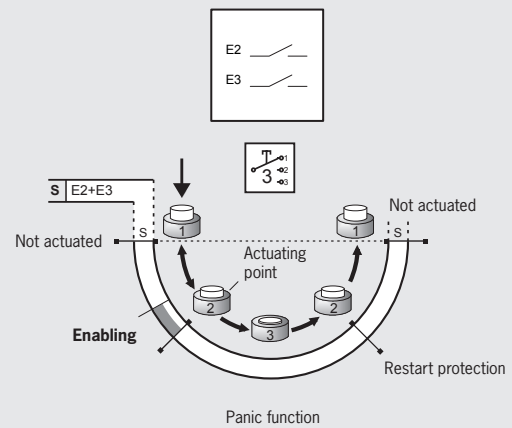
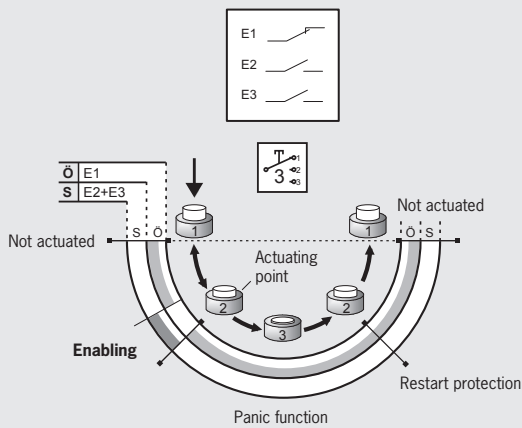

Ordering table

Design	Connection	Cable length	Version	Order no./item
ZSM	Flying lead 23 x 0.14 mm ²	1.88 ... 5 m coiled	Enabling switch with 1 NC contact and 2 NO contacts (S4), red emergency stop device (S1), yellow LED indicator (P1), +/- buttons (S2/S3)	138119 ZSM2204-138119
	Flying lead 12 x 0.14 mm ²	2.85 ... 4.8 m coiled	Enabling switch with 2 NO contacts (S4), gray machine stop (S1), +/- buttons (S2/S3)	126706 ZSM2201-126706

For technical data, see page 71

Enabling switch ZSM with lower stop command device



- ▶ 3-stage function
- ▶ Stop command device
- ▶ Vibration signal optional
- ▶ LED indicator
- ▶ Reset button optional
- ▶ + and – buttons
- ▶ Selector switch optional
- ▶ Key-operated rotary switch optional
- ▶ Coiled connecting cable optional
- ▶ Plug connector optional

3-stage function

Enabling function is active only in the second stage (center position, actuating point). If the pushbutton is released or pushed further (panic function), the enabling is removed (dependent on the wiring, see function sequence).

Stop command device

Dual-channel emergency stop device (red, with pull-to-reset and turn-to-reset button) or machine stop (gray, with pull-to-reset and turn-to-reset button) on the switch housing, for different wiring concepts. Lower position, protected by anti-kink strain relief in case of a fall.

Vibration signal

The vibration signal is used for tactile feedback of the enabling position.

LED indicator

The LED indicator is used for visual feedback directly at the enabling switch.

Reset button

Pushbutton for reset function directly from the enabling switch. Laser inscription on button head: **C** (cancel).

+ and – buttons

These pushbuttons can be configured individually. For example, for moving axes in the positive or negative direction.

Selector switch

The adjustable detent positions can be used as required for axis, speed or range selection, for example.

Key-operated rotary switch

For individual use, e.g. as operating mode selector.

Cable

The high-quality connecting cables are available in a straight or coiled version.

ZSM2101-103126, 3-stage function

Flying lead, emergency stop device

ZSM2204-117128, 3-stage function

Flying lead, emergency stop device

Dimension drawing

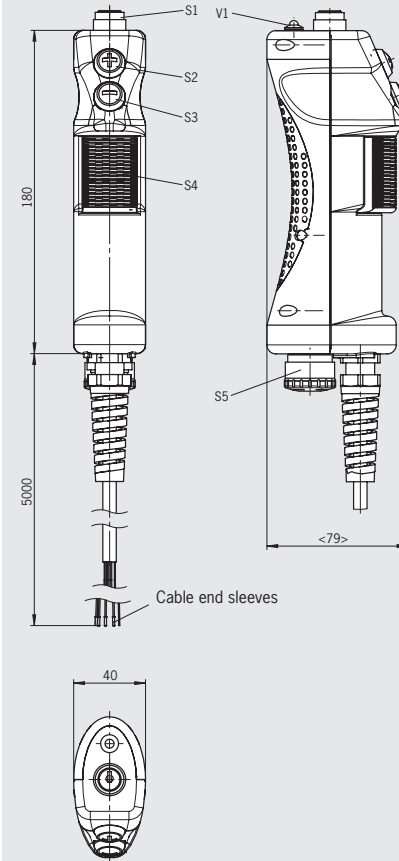

For wiring diagram, see page 73

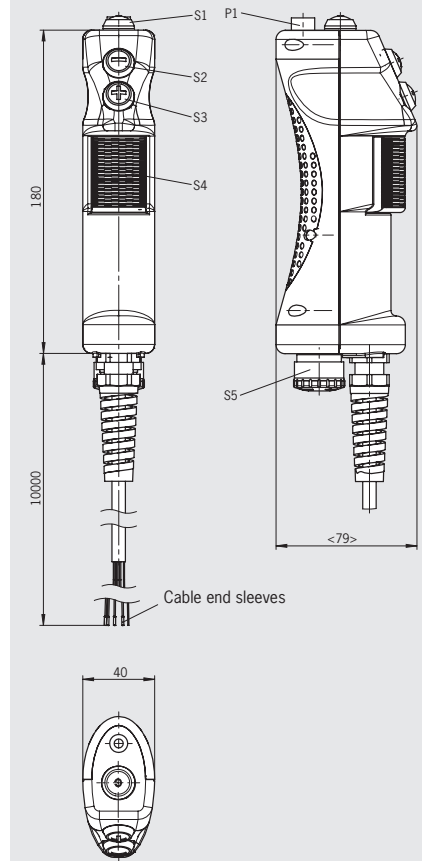

For wiring diagram, see page 73

Switching element/function sequence

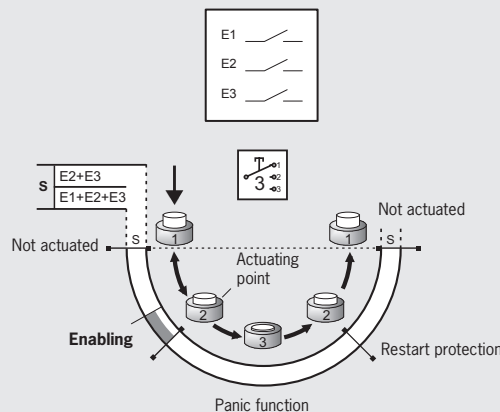

Ordering table

Design	Connection	Cable length	Version	Order no./item
ZSM	Flying lead 23 x 0.14 mm ²	5 m straight	Enabling switch with 3 NO contacts (S4), red emergency stop device (S5), vibration signal, yellow LED indicator (V1), +/- buttons (S2/S3), key-operated rotary switch (S1)	103126 ZSM2101-103126
		10 m straight	Enabling switch with 3 NO contacts (S4), red emergency stop device (S5), vibration signal, red/green LED indicator (P1), +/- buttons (S3/S23), black pushbutton (S1)	117128 ZSM2204-117128



ZSM2104-123678, 3-stage function
Plug connector RC12, emergency stop device

ZSM2301-110317, 3-stage function
Plug connector RC17, machine stop

ZSM2304-111595, 3-stage function
Plug connector RC17, emergency stop device

Dimension drawing

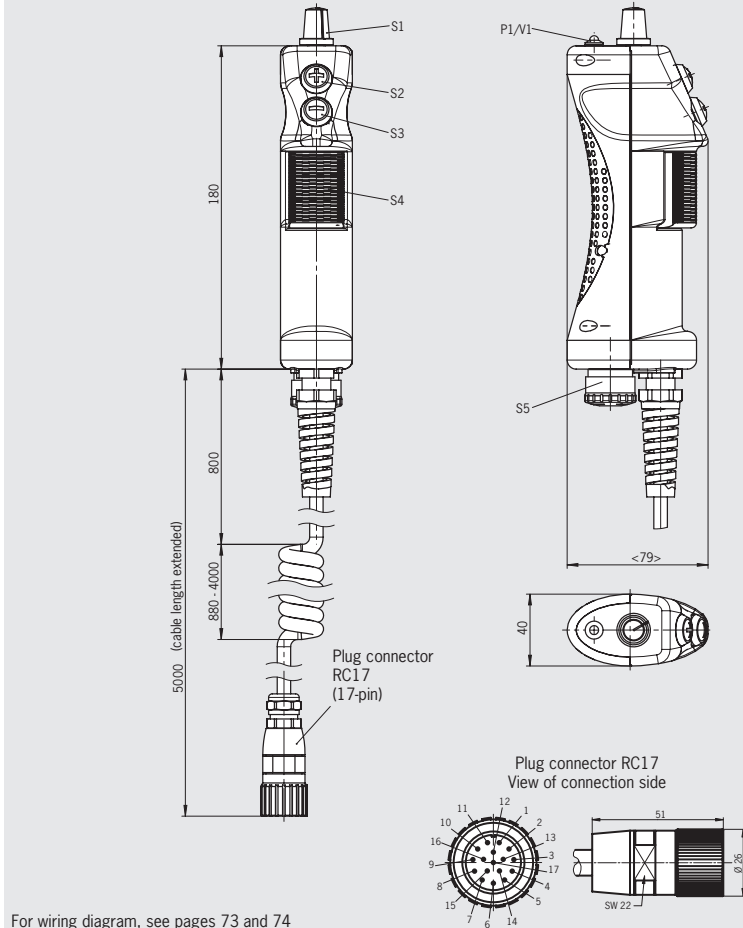
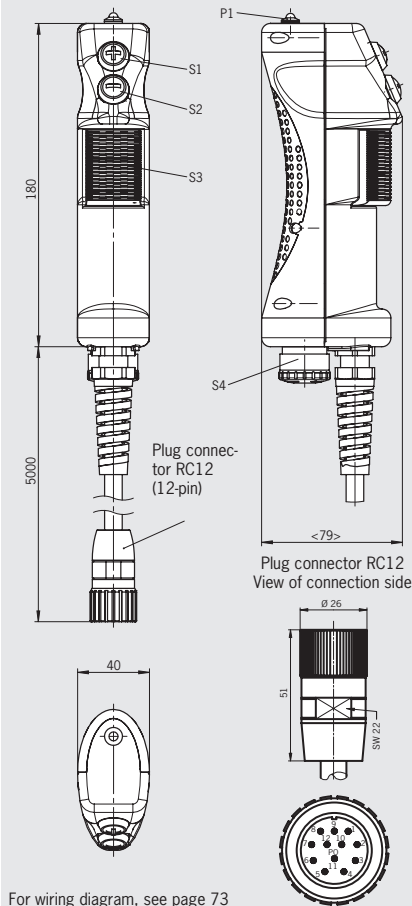

Please turn page

Switching element/function sequence

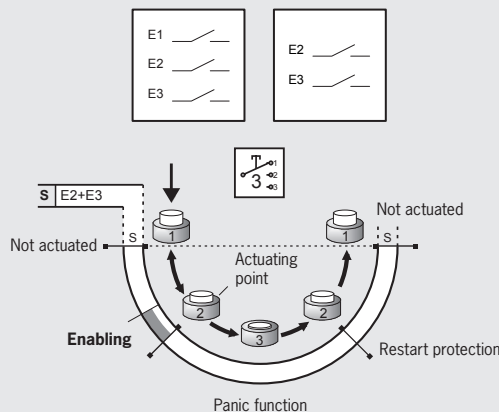

Ordering table

Design	Connection	Cable length	Version	Order no./item
ZSM	RC12 Plug connector (12-pin)	5 m straight	Enabling switch with 3 NO contacts (S3), red emergency stop device (S4), yellow LED indicator (P1), +/- buttons (S1/S2)	123678 ZSM2104-123678
	RC17 Plug connector (17-pin)	1.88 ... 5 m coiled	Enabling switch with 2 NO contacts (S4), gray machine stop (S5), yellow LED indicator (V1), +/- buttons (S2/S3), selector switch, 3-stage, 1 of 3 (S1)	110317 ZSM2301-110317
			Enabling switch with 2 NO contacts (S4), red emergency stop device (S5), yellow LED indicator (P1), +/- buttons (S2/S3), selector switch, 3-stage, 1 of 3 (S1)	111595 ZSM2304-111595



ZSM2301-105075, 3-stage function
 Plug connector HAN Q17, machine stop

Dimension drawing

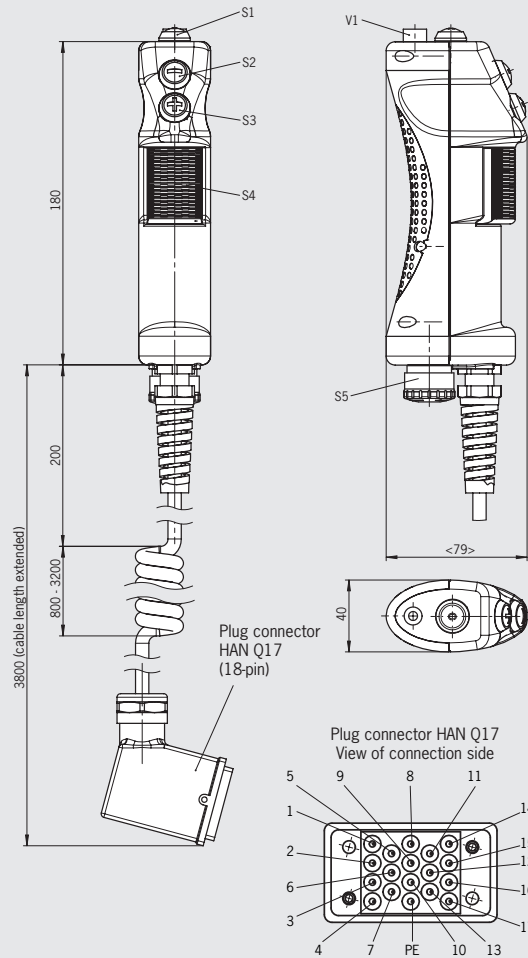

For wiring diagram, see page 74

Switching element/function sequence

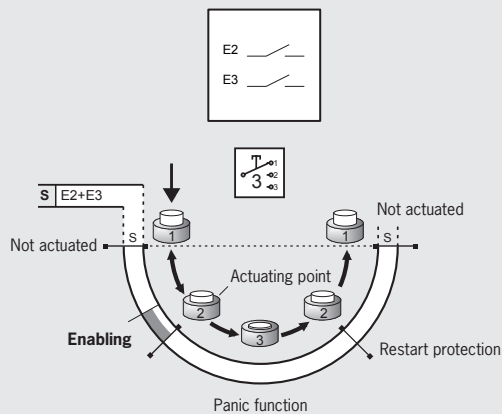

Ordering table

Design	Connection	Cable length	Version	Order no./item
ZSM	HAN Q17 Plug connector (18-pin)	1.4 ... 3.8 m coiled	Enabling switch with 2 NO contacts (S4), gray machine stop (S5), vibration signal, red/green LED indicator (V1), +/- buttons (S3/S2), reset button (S1)	105075 ZSM2301-105075

Enabling switch ZSM without stop command device



- ▶ 3-stage function
- ▶ Vibration signal optional
- ▶ LED indicator optional
- ▶ + and - buttons optional
- ▶ Coiled connecting cable optional
- ▶ Plug connector optional

ZSM4200-099713, 3-stage function
Flying lead

ZSM4200-121883, 3-stage function
Flying lead

3-stage function

Enabling function is active only in the second stage (center position, actuating point). If the pushbutton is released or pushed further (panic function), the enabling is removed (dependent on the wiring, see function sequence).

Vibration signal

The vibration signal is used for tactile feedback of the enabling position.

LED indicator

The LED indicator is used for visual feedback directly at the enabling switch.

Pushbuttons

Additional functions can be run directly at the enabling switch using the pushbuttons.

+ and - buttons

These pushbuttons can be configured individually. For example, for moving axes in the positive or negative direction.

Cable

The high-quality connecting cables are available in a straight or coiled version.

Dimension drawing

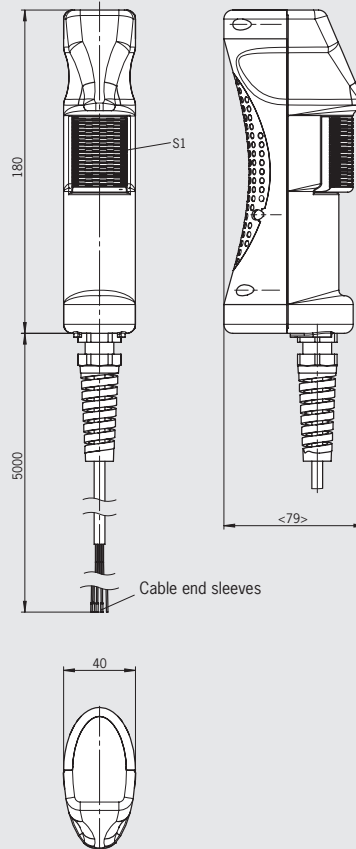

For wiring diagram, see page 74

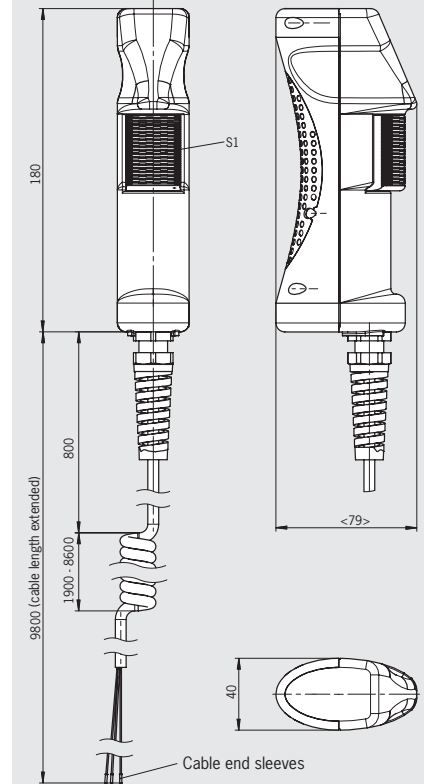

For wiring diagram, see page 74

Switching element/function sequence

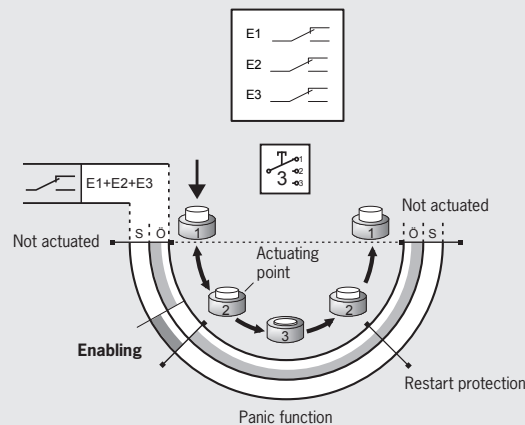

Ordering table

Design	Connection	Cable length	Version	Order no./item
ZSM	Flying lead 12 x 0.14 mm ²	5 m straight	Enabling switch with 3 changeover contacts (S1)	099713 ZSM4200-099713
		3.1 ... 9.8 m coiled	Enabling switch with 3 changeover contacts (S1)	121883 ZSM4200-121883



ZSM2300-111871, 3-stage function Flying lead

Dimension drawing

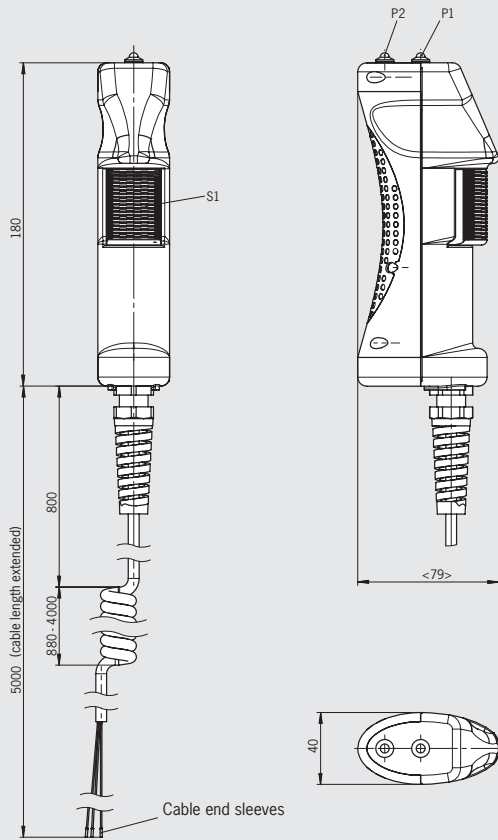

For wiring diagram, see page 75

ZSM4200-124156, 3-stage function Flying lead

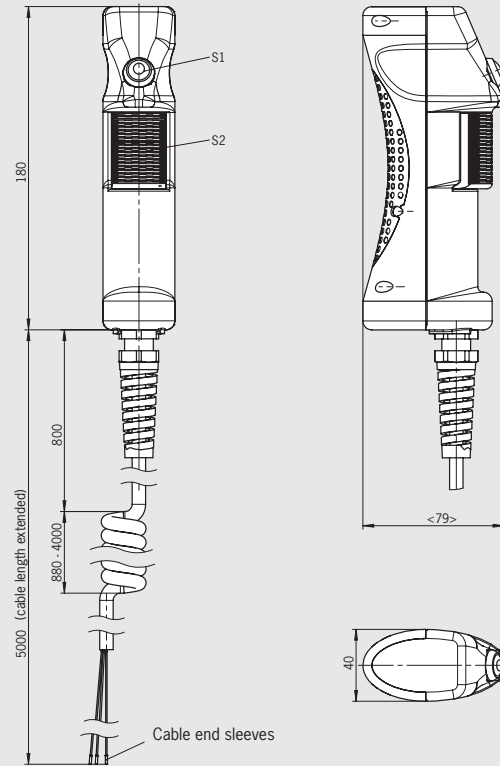

For wiring diagram, see page 75

Switching element/function sequence

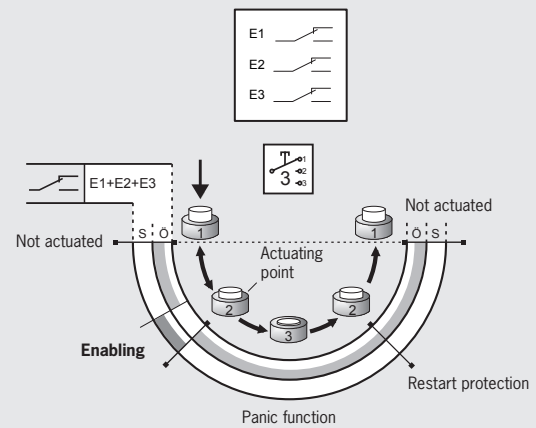
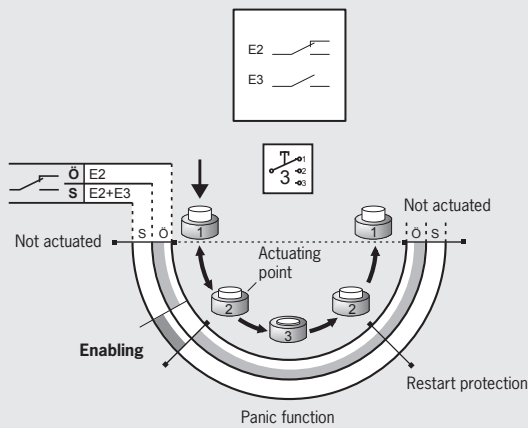

Ordering table

Design	Connection	Cable length	Version	Order no./item
ZSM	Flying lead 12 x 0.14 mm ²	1.88 ... 5 m coiled	Enabling switch with 1 changeover contact and one NO contact (S1), 2 green (P1) and yellow (P2) LED indicators	111871 ZSM2300-111871
			Enabling switch with 3 changeover contacts (S2), black pushbutton (S1)	124156 ZSM4200-124156



ZSM2100-099714, 3-stage function
Flying lead

ZSM2300-109971, 3-stage function
Flying lead

ZSM2100-112803, 3-stage function
Flying lead

Dimension drawing

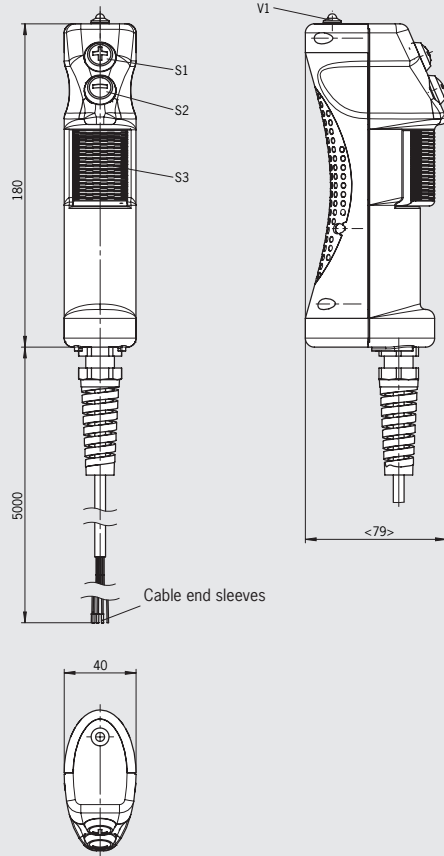

For wiring diagram, see page 75

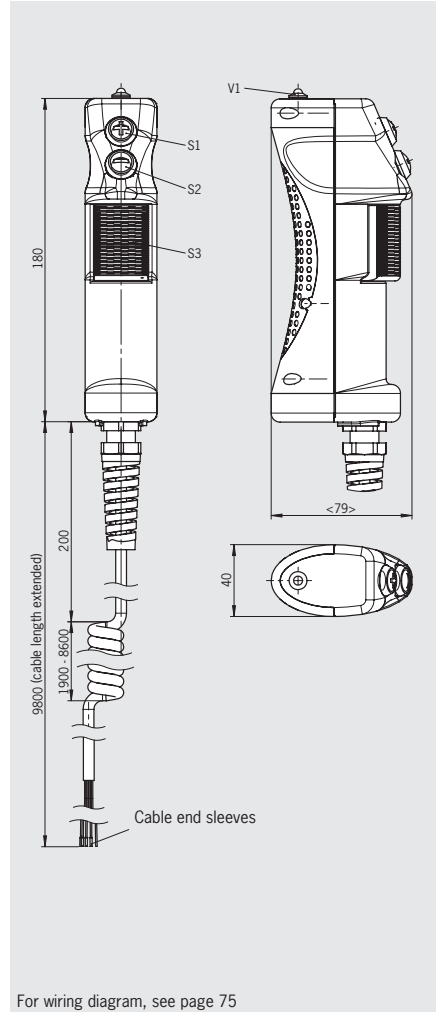

For wiring diagram, see page 75

Please turn page

Switching element/function sequence

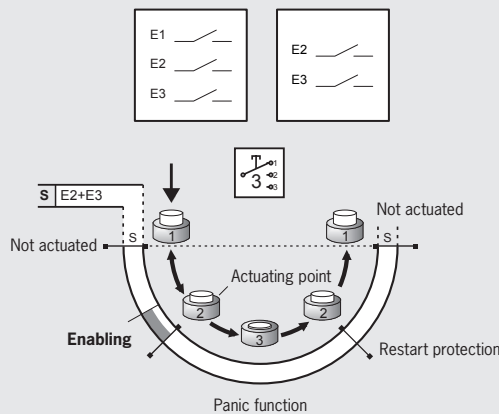

Ordering table

Design	Connection	Cable length	Version	Order no./item
ZSM	Flying lead 12 x 0.14 mm ²	5 m straight	Enabling switch with 3 NO contacts (S3), vibration signal, yellow LED indicator (V1), +/- buttons (S1/S2)	099714 ZSM2100-099714
			Enabling switch with 2 NO contacts (S3), vibration signal, yellow LED indicator (V1), +/- buttons (S1/S2), alternative wiring	109971 ZSM2300-109971
		3 ... 9 m coiled	Enabling switch with 2 NO contacts (S3), vibration signal, yellow LED indicator (V1), +/- buttons (S1/S2), alternative wiring	112803 ZSM2300-112803

For technical data, see page 71



ZSM2300-127990, 3-stage function Flying lead

ZSM2300-111462, 3-stage function Plug connector RC12

Dimension drawing

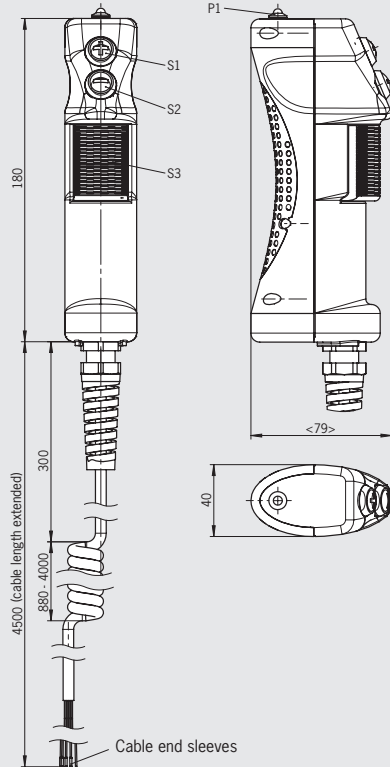

For wiring diagram, see page 76

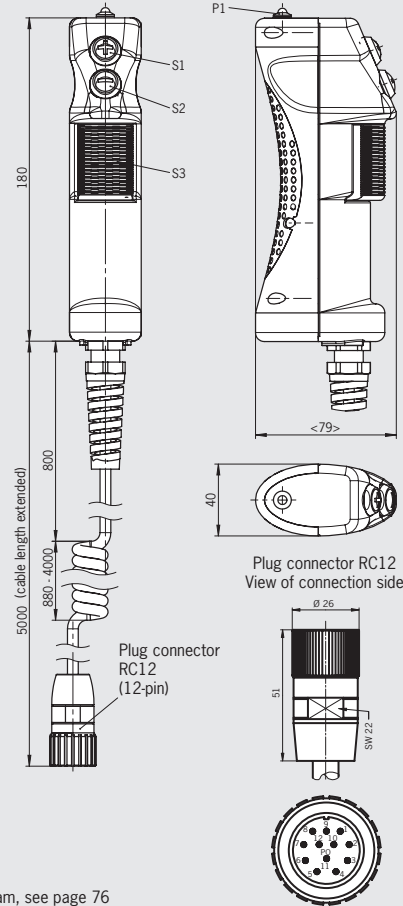

For wiring diagram, see page 76
For mating connector, see page 66

Switching element/function sequence

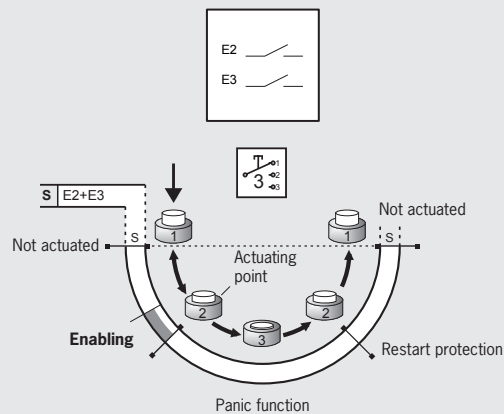

Ordering table

Design	Connection	Cable length	Version	Order no./item
ZSM	Flying lead 12 x 0.14 mm ²	1.38 ... 4.5 m coiled	Enabling switch with 2 NO contacts (S3), vibration signal, yellow LED indicator (P1), +/- buttons (S1/S2)	127990 ZSM2300-127990
	RC12 Plug connector (12-pin)	1.88 ... 5 m coiled	Enabling switch with 2 NO contacts (S3), vibration signal, yellow LED indicator (P1), +/- buttons (S1/S2)	111462 ZSM2300-111462



ZSM2300-099716, 3-stage function
Plug connector RC12

ZSM2300-113290, 3-stage function
Plug connector RC12

Dimension drawing

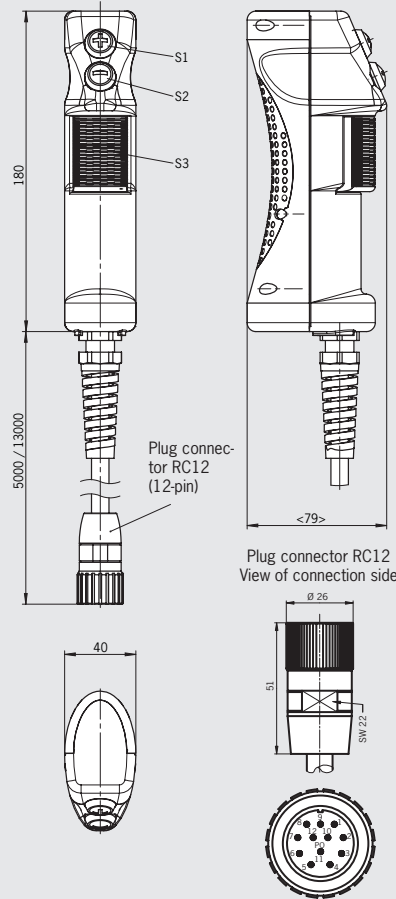

For wiring diagram, see page 76
For mating connector, see page 66

Switching element/function sequence

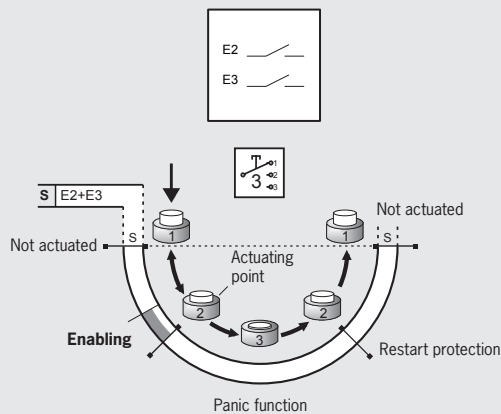

Ordering table

Design	Connection	Cable length	Version	Order no./item
ZSM	RC12 Plug connector (12-pin)	5 m straight	Enabling switch with 2 NO contacts (S3), +/- buttons (S1/S2)	099716 ZSM2300-099716
		13 m straight	Enabling switch with 2 NO contacts (S3), +/- buttons (S1/S2)	113290 ZSM2300-113290

For technical data, see page 71

Enabling switch ZSM without stop command device



- ▶ 3-stage function
- ▶ Vibration signal optional
- ▶ LED indicator optional
- ▶ + and – buttons
- ▶ Selector switch
- ▶ Coiled connecting cable optional
- ▶ Plug connector optional

3-stage function

Enabling function is active only in the second stage (center position, actuating point). If the pushbutton is released or pushed further (panic function), the enabling is removed (dependent on the wiring, see function sequence).

Vibration signal

The vibration signal is used for tactile feedback of the enabling position.

LED indicator

The LED indicator is used for visual feedback directly at the enabling switch.

+ and – buttons

These pushbuttons can be configured individually. For example, for moving axes in the positive or negative direction.

Selector switch

The adjustable detent positions can be used as required for axis, speed or range selection, for example.

Cable

The high-quality connecting cables are available in a straight or coiled version.

ZSM2200-100697, 3-stage function

Flying lead, selector switch

Dimension drawing

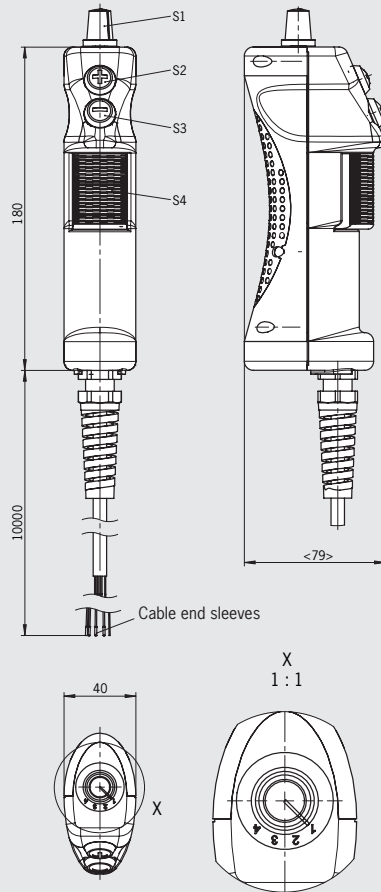

For wiring diagram, see page 76

ZSM2100-106103, 3-stage function

Flying lead, selector switch

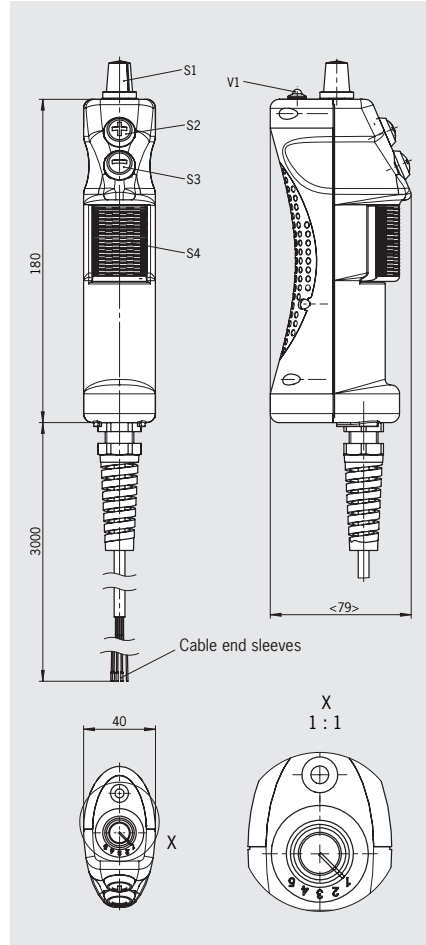

For wiring diagram, see page 77

Switching element/function sequence

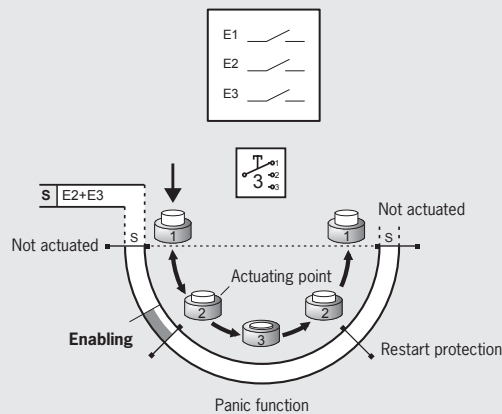

Ordering table

Design	Connection	Cable length	Version	Order no./item
ZSM	Flying lead 23 x 0.14 mm ²	10 m straight	Enabling switch with 3 NO contacts (S4), vibration signal, +/- buttons (S2/S3), selector switch, 4-stage, 1 of 4 (S1)	100697 ZSM2200-100697
	Flying lead 12 x 0.14 mm ²	3 m straight	Enabling switch with 3 NO contacts (S4), yellow LED indicator (V1), +/- buttons (S2/S3), selector switch, 5-stage, Gray code (S1)	106103 ZSM2100-106103



ZSM2200-105308, 3-stage function

Flying lead, selector switch

ZSM3100-103462, 3-stage function

Flying lead, selector switch

Dimension drawing

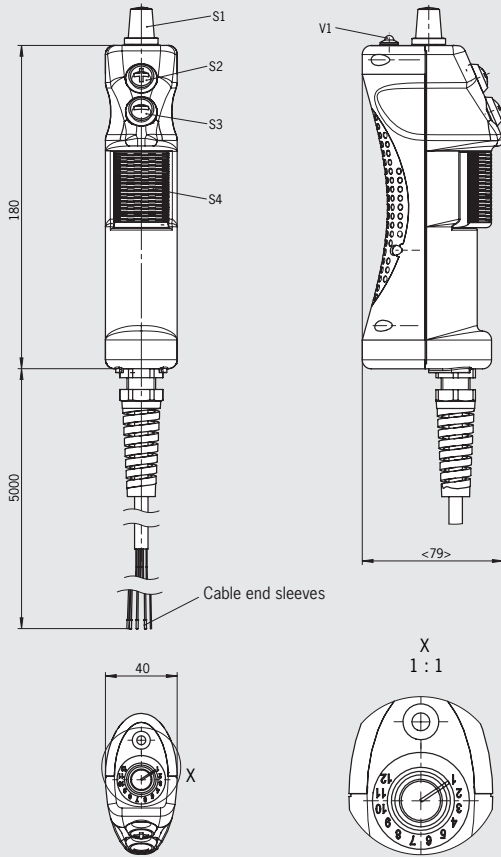

For wiring diagram, see page 77

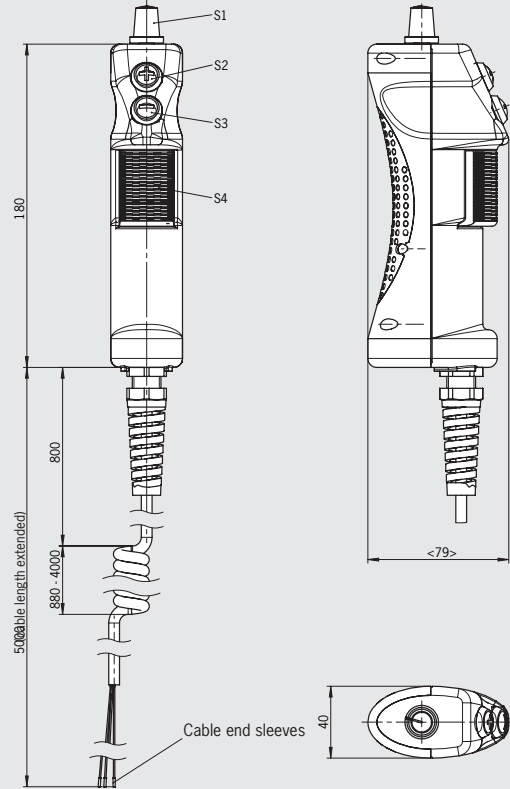

For wiring diagram, see page 77

Please turn page

Switching element/function sequence

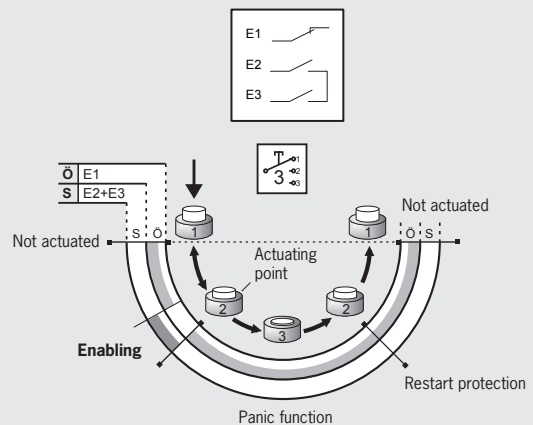
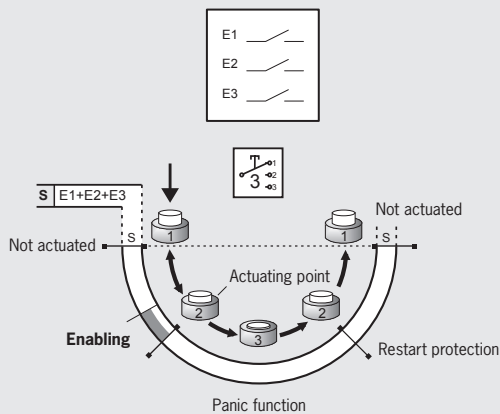

Ordering table

Design	Connection	Cable length	Version	Order no./item
ZSM	Flying lead 23 x 0.14 mm ²	5 m straight	Enabling switch with 3 NO contacts (S4), yellow LED indicator (V1), +/- buttons (S2/S3), selector switch, 12-stage, Gray code (S1)	105308 ZSM2200-105308
	Flying lead 12 x 0.14 mm ²	1.88 ... 5 m coiled	Enabling switch with 1 NC contact and 2 NO contacts (S4), +/- buttons (S2/S3), selector switch, 12-stage, Gray code (S1)	103462 ZSM3100-103462



ZSM2200-122279, 3-stage function
 Plug connector RC12, selector switch

Dimension drawing

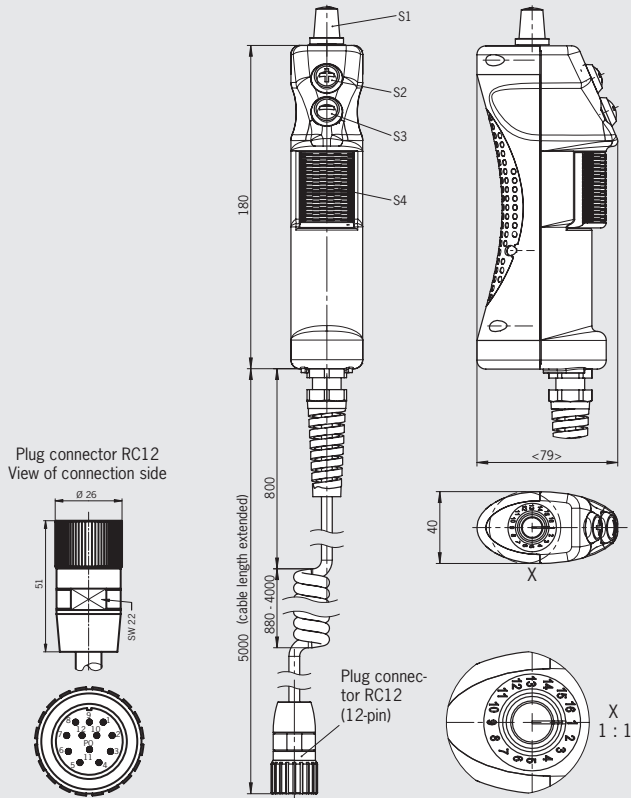

For wiring diagram, see page 77
 For mating connector, see page 66

Switching element/function sequence

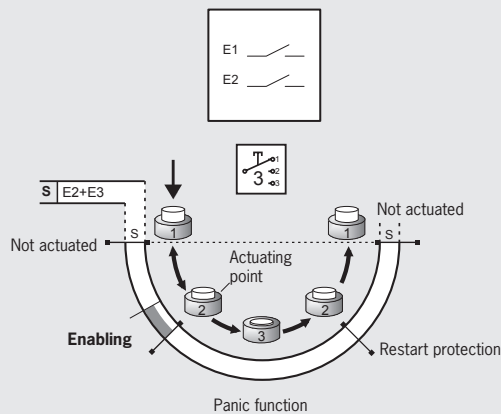

Ordering table

Design	Connection	Cable length	Version	Order no./item
ZSM	RC12 Plug connector (12-pin)	1.88 ... 5 m coiled	Enabling switch with 2 NO contacts (S4), +/- buttons (S2/S3), selector switch, 16-stage, Gray code (S1)	122279 ZSM2200-122279



Enabling switch ZSM without stop command device

- ▶ 3-stage function
- ▶ Vibration signal optional
- ▶ LED indicator optional
- ▶ Reset button optional
- ▶ + and – buttons optional
- ▶ Pushbutton optional
- ▶ Key-operated rotary switch optional
- ▶ Mini joystick optional
- ▶ Coiled connecting cable optional
- ▶ Plug connector optional

3-stage function

Enabling function is active only in the second stage (center position, actuating point). If the pushbutton is released or pushed further (panic function), the enabling is removed (dependent on the wiring, see function sequence).

Vibration signal

The vibration signal is used for tactile feedback of the enabling position.

LED indicator

The LED indicator is used for visual feedback directly at the enabling switch.

Reset button

Button for reset function directly from the enabling switch. Laser inscription on button head: **C** (cancel).

+ and – buttons

These pushbuttons can be configured individually. For example, for moving axes in the positive or negative direction.

Pushbuttons

Additional functions can be run directly at the enabling switch using the pushbuttons.

Key-operated rotary switch

For individual use, e.g. as operating mode selector.

Mini joystick

Four different operating directions are possible with the mini joystick. All contacts are optionally connected to a common pin. This permits a one-touch function irrespective of the actuating direction.

Cable

The high-quality connecting cables are available in a straight or coiled version.

ZSM2200-116714, 3-stage function

Flying lead, key-operated rotary switch

Dimension drawing

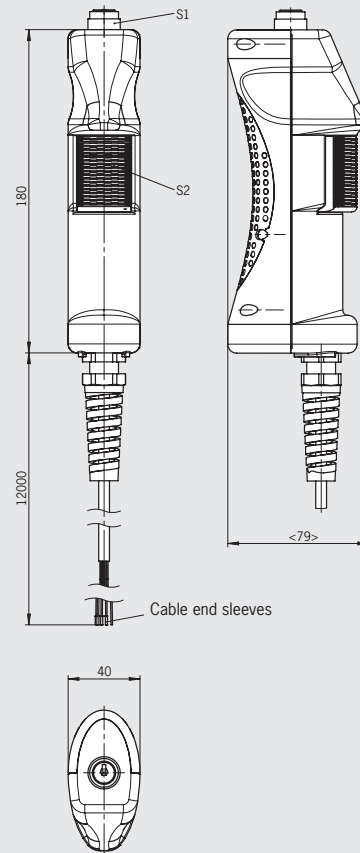

For wiring diagram, see page 78

Switching element/function sequence

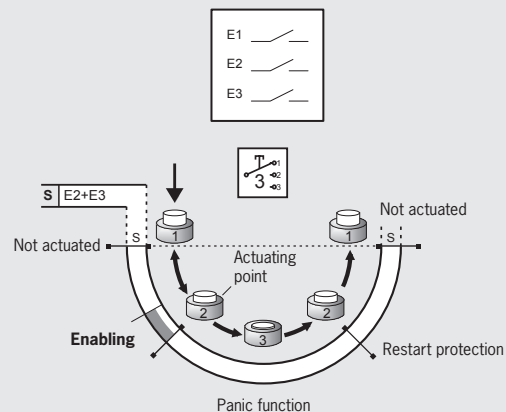

Ordering table

Design	Connection	Cable length	Version	Order no./item
ZSM	Flying lead 12 x 0.14 mm ²	12 m straight	Enabling switch with 3 NO contacts (S2), vibration signal, key-operated rotary switch (S1)	116714 ZSM2200-116714



ZSM2300-110338, 3-stage function
Plug connector RC12, key-operated rotary switch

ZSM2300-106670, 3-stage function
Plug connector HAN Q17, reset button

Dimension drawing

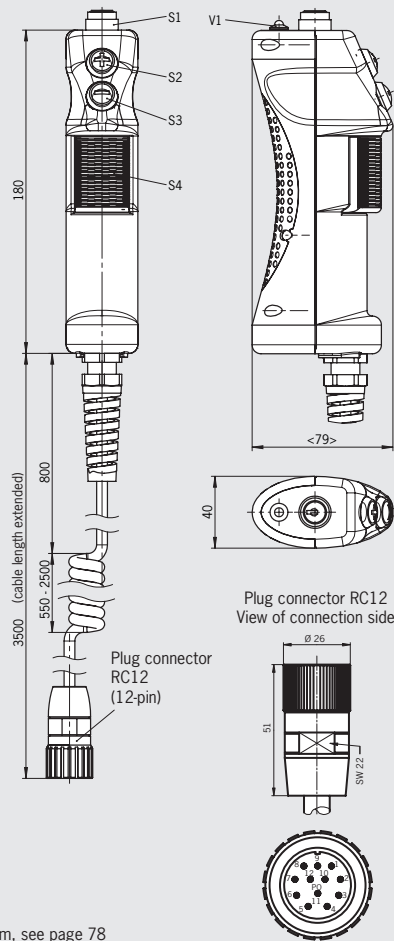

For wiring diagram, see page 78
For mating connector, see page 66

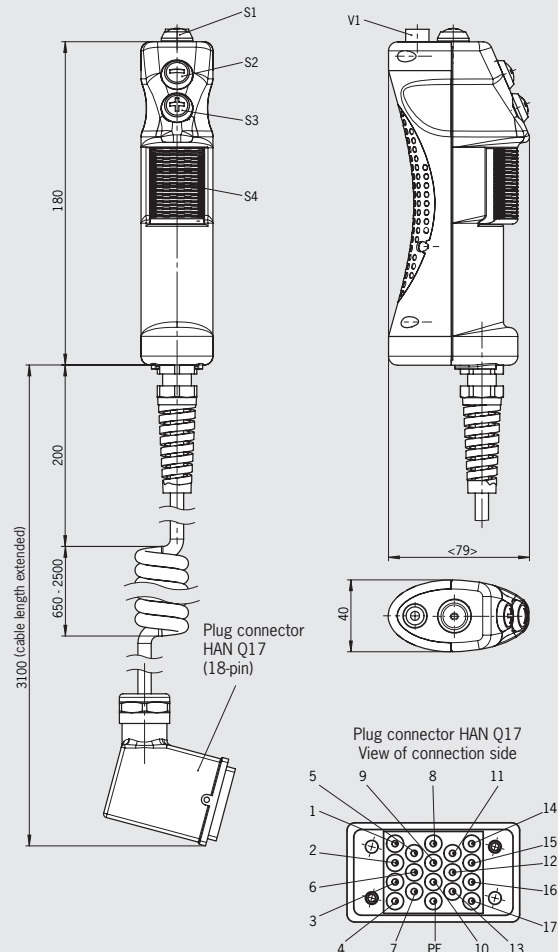

For wiring diagram, see page 78

Switching element/function sequence

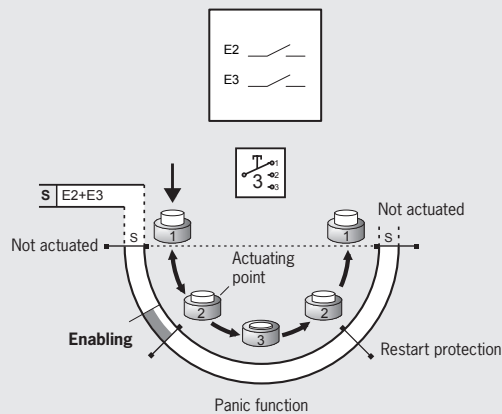

Ordering table

Design	Connection	Cable length	Version	Order no./item
ZSM	RC12 Plug connector (12-pin)	1.55 ... 3.5 m coiled	Enabling switch with 2 NO contacts (S4), yellow LED indicator (V1), +/- buttons (S2/S3), key-operated rotary switch (S1)	110338 ZSM2300-110338
	HAN Q17 Plug connector (18-pin)	1.25 ... 3.1 m coiled	Enabling switch with 2 NO contacts (S4), vibration signal, yellow LED indicator (V1), +/- buttons (S3/S2), reset button (S1)	106670 ZSM2300-106670



ZSM2200-157209, 3-stage function

Flying lead, mini joystick

ZSM2300-106374, 3-stage function

Plug connector RC17, mini joystick (one-touch function)

Dimension drawing

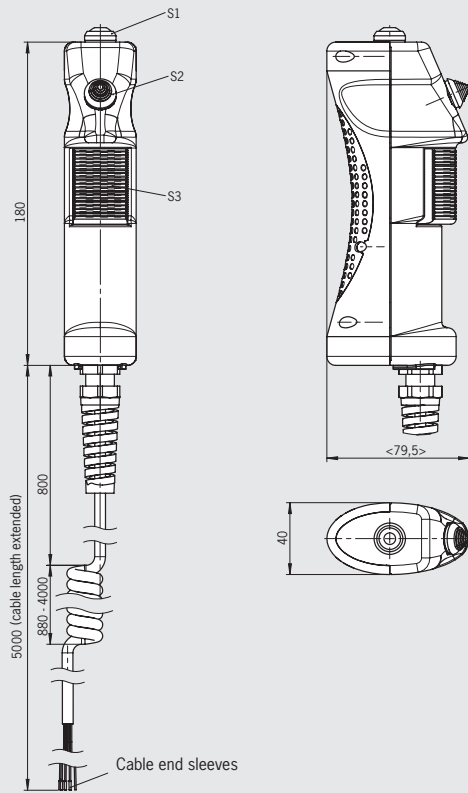

For wiring diagram, see page 78

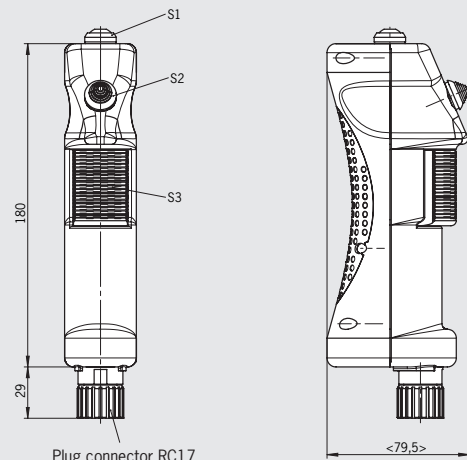

Plug connector RC17
(17-pin)



Plug connector RC17
View of connection side

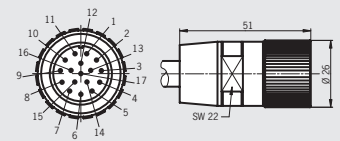

For wiring diagram, see page 79
For mating connector, see page 66
For connecting cable, see page 68

Switching element/function sequence

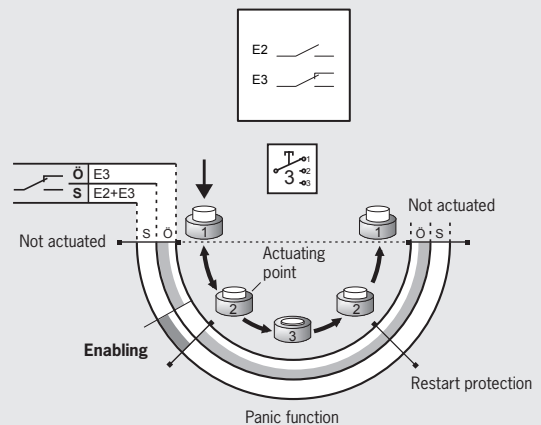
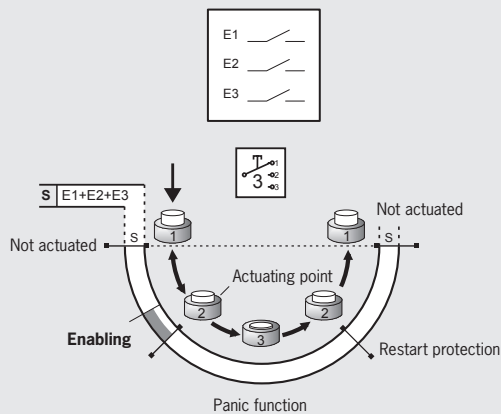

Ordering table

Design	Connection	Cable length	Version	Order no./item
ZSM	Flying lead 12 x 0.14 mm ²	1.88 ... 5 m coiled	Enabling switch with 3 NO contacts (S3), mini joystick (S2), black pushbutton (S1)	157209 ZSM2200-157209
	RC17 Plug connector (17-pin)	Without cable	Enabling switch with 1 NO contact and 1 changeover contact (S3), one-touch function (S2), black pushbutton (S1)	106374 ZSM2300-106374

For technical data, see page 71

Selection table for enabling switches ZSA, ZSB and ZSR

Design										
G1	Housing G1 (black)									
G2	Housing G2 (yellow)									
G3	Housing G3 (yellow)									
Function										
3	3-stage (OFF - enabling - OFF)									
Connection										
C	Flying lead									
SVM5	Plug connector M12, 5-pin									
HAN10	Plug connector, 10-pin + PE									
RC12	Plug connector, 11-pin + PE									
RC17	Plug connector, 17-pin									
Additional elements										
Z	Additional elements, e.g. pushbuttons, LEDs, key-operated rotary switches, selector switches, etc.									

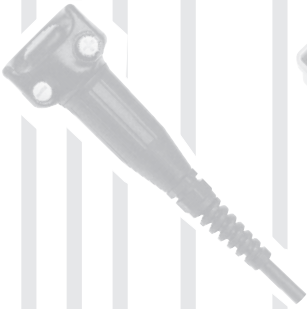

**Enabling switch
ZSA/ZSB
Housing G1**

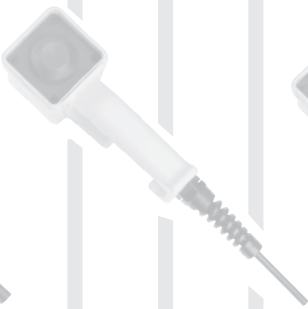

**Enabling switch ZSR
Housing G2**

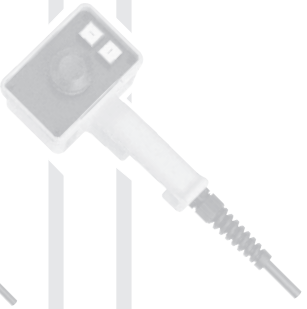

**Enabling switch ZSB
Housing G3**

G1	G2	G3	Stages	3	C	SVM5	HAN10	RC12	RC17	Z	Page
●			●	●							34/35
●			●			●					36
●			●				●	●			37
●			●	●						●	38/39
●			●					●	●	●	40
●			●				●			●	41
	●		●	●							42
		●	●	●						●	43/44
		●	●					●		●	43/47
		●	●						●	●	45/46



Enabling switch ZSA

- ▶ Housing G1
- ▶ 3-stage function
- ▶ Single-channel or dual-channel version
- ▶ Connecting cable straight or coiled
- ▶ Wall holder optional



ZSA, 3-stage function

Flying lead

Dimension drawings

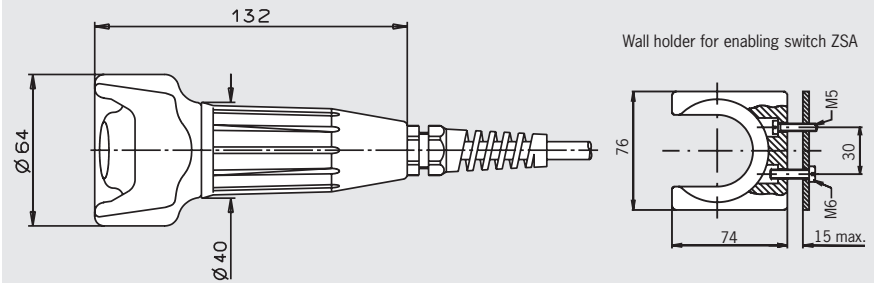

3-stage function

Enabling function is active only in the second stage (center position, actuating point). If the pushbutton is released or pushed further (panic function), the enabling is removed (dependent on the wiring, see function sequence).

Cable

The high-quality connecting cables (individual shielding of the safety contacts) are available in a straight or coiled version.

Switching elements (see also page 8)

- ▶ **111** 1 NO + 1 NC ⊖ + 1 NC
- ▶ **121** 1 NO + 2 NC ⊖ + 1 NC
- ▶ **210** 2 NO + 1 NC ⊖
- ▶ **220** 2 NO + 2 NC ⊖

Cable lengths (coiled cable pulled out straight)

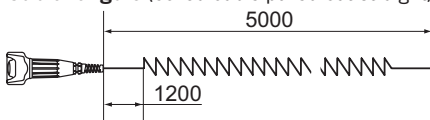

Wiring diagrams/function sequence

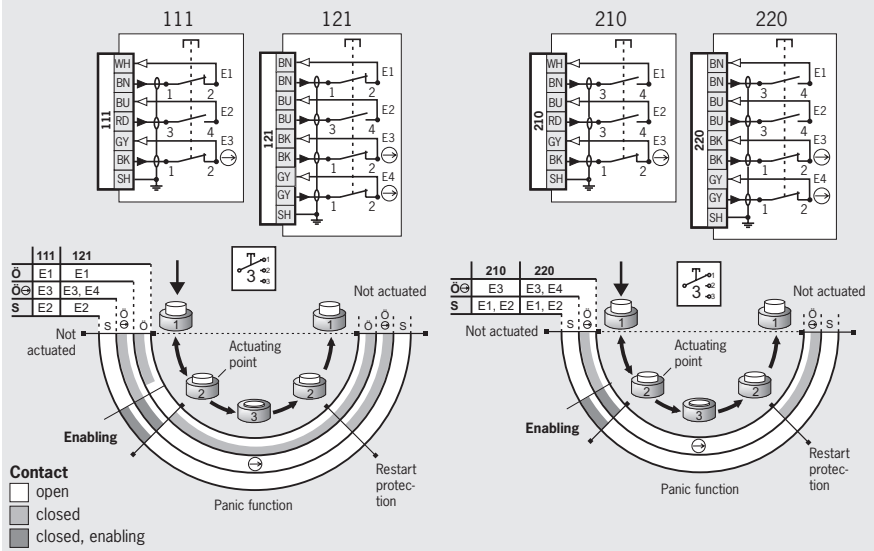

Ordering table

Design	Connection/ cross-section	Cable length	Version	Switching element			
				111: 1NO+1NC ⊖ +1NC	121: 1NO+2NC ⊖ + 1NC	210: 2NO+1NC ⊖	220: 2NO+2NC ⊖
G1 3-stage	Flying lead 6 x 0.34 mm ²	2 m straight		On request	-	099371 ZSA2A2G02A	-
		5 m straight		055402 ZSA2A1G05A	-	055406 ZSA2A2G05A	-
		5 m coiled		055404 ZSA2A1S05A	-	055408 ZSA2A2S05A	-
		10 m straight		055403 ZSA2A1G10A	-	055407 ZSA2A2G10A	-
		15 m straight		On request	-	057007 ZSA2A2G15A	-
	Flying lead 8 x 0.34 mm ²	2.5 m straight	Incl. wall holder	-	On request	-	086788 ^{1) 2)} ZSA2A4L25AC1689
		5 m straight		-	On request	-	070764 ZSA2A4G05A
		5 m coiled		-	On request	-	070766 ZSA2A4S05A
		10 m straight		-	070785 ZSA2A3G10A	-	070765 ZSA2A4G10A
		20 m straight		-	On request	-	073300 ZSA2A4G20A

1) No BG type examination

2) No cULus type examination



Enabling switch ZSA

- ▶ Housing G1
- ▶ 3-stage function
- ▶ Single-channel or dual-channel version
- ▶ Connecting cable straight or coiled
- ▶ Plug connector optional



3-stage function

Enabling function is active only in the second stage (center position, actuating point). If the button is released or pushed further (panic function), the enabling is removed (dependent on the wiring, see function sequence)

Cable

The high-quality connecting cables (individual shielding of the safety contacts) are available in a straight or coiled version.

Switching elements (see also page 8)

- ▶ **1210** 1 NO/NC ⊖¹⁾ + 1 NO
- ▶ **2210** 1 NO/NC ⊖¹⁾
1 S (additional monitoring contact)
- ▶ **2220** 2 NO/NC ⊖¹⁾

Cable lengths (coiled cable pulled out straight)

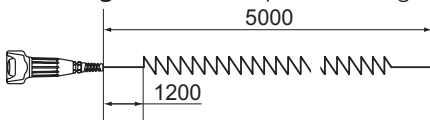

ZSA, 3-stage function

Flying lead

Dimension drawings

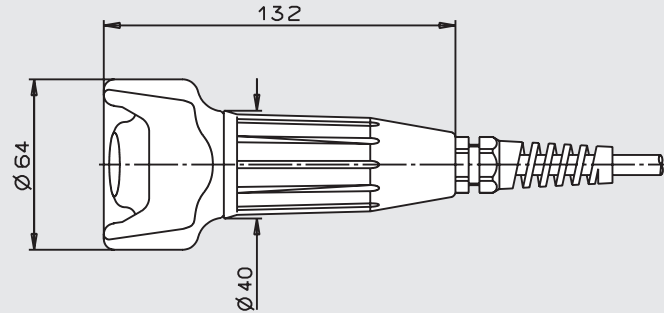

Wiring diagrams/function sequence

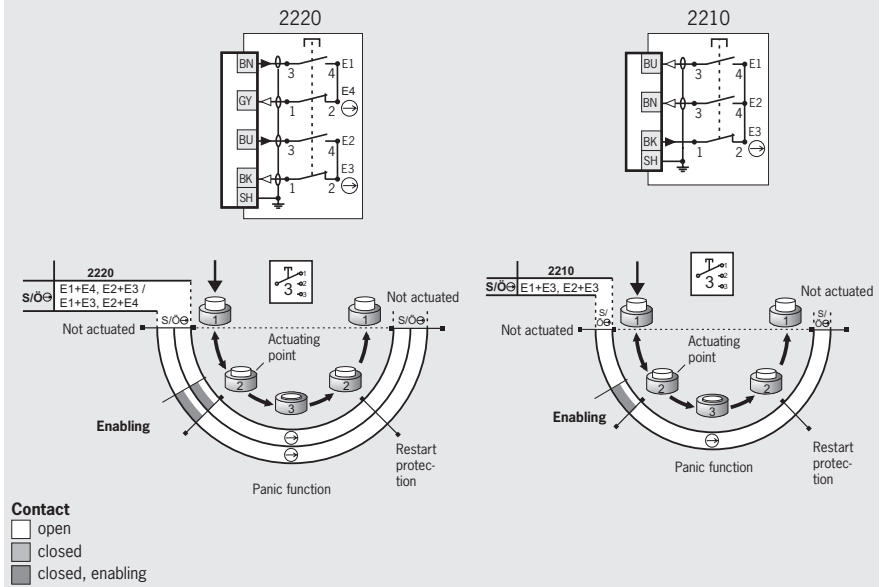

Ordering table

Design	Connection/ cross-section	Cable length	Switching element	
			2210: 1NO/NC ⊖ ¹⁾ +1NO	2220: 2NO/NC ⊖ ¹⁾
G1 3-stage	Flying lead 8 x 0.34 mm ²	5 m straight	On request	072961 ZSA2B4G05A
		5 m coiled	On request	085118 ZSA2B4S05A
	Flying lead 3 x 0.75 mm ²	5 m straight	055410 ZSA2B2G05A	-
		10 m straight	055411 ZSA2B2G10A	-

1) Closed only in center position; one NO contact and one positively driven contact are combined internally.



ZSA, 3-stage function Plug connector

Dimension drawings

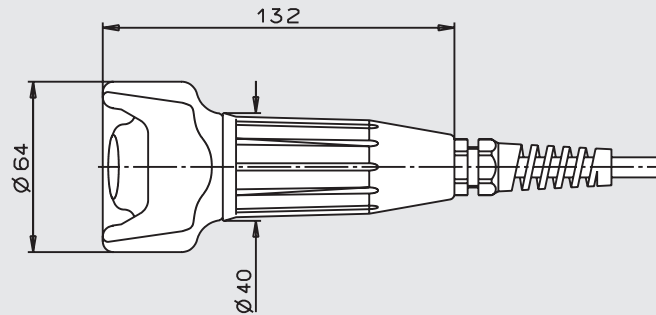

Male plug SVM5 (5-pin)

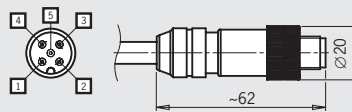

For mating connector, see page 69

View of connection side

Wiring diagrams/function sequence

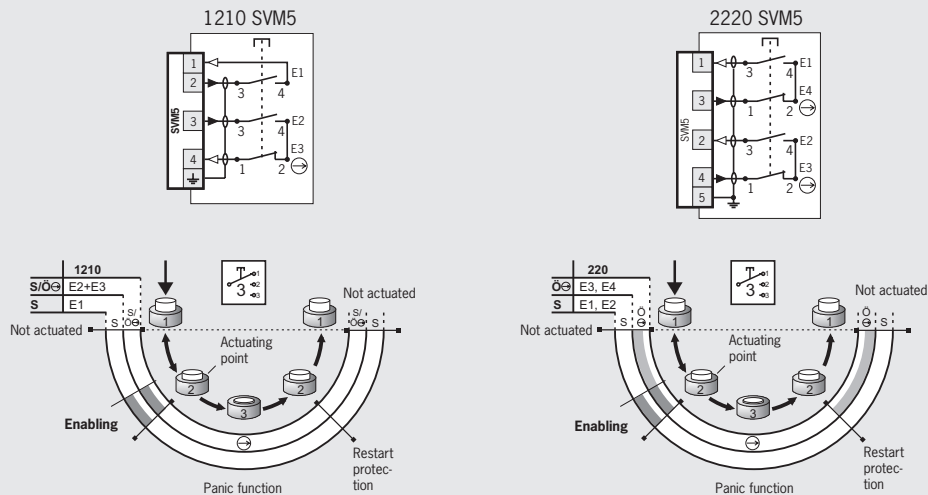

Contact
 open
 closed
 closed, enabling

Ordering table

Design	Connection	Cable length	Switching element	
			1210: 1NO/NC \ominus ¹⁾ + 1NO	2220: 2NO/NC \ominus ¹⁾
G1 3-stage	SVM5 Plug connector (5-pin)	10 m straight	On request	110560 ZSA2B4G10CC2322
		15 m straight	072870 ZSA2B2G15CC1926	On request
		25 m straight	On request	On request

1) Closed only in center position; one NO contact and one positively driven contact are combined internally.



Enabling switch ZSA

- ▶ Housing G1
- ▶ 3-stage function
- ▶ Single-channel or dual-channel version
- ▶ Straight connecting cable
- ▶ Plug connector
- ▶ Direct connection to safety switch optional
- ▶ Increased actuating force optional



3-stage function

Enabling function is active only in the second stage (center position, actuating point). If the pushbutton is released or pushed further (panic function), the enabling is removed (dependent on the wiring, see function sequence).

Cable

The high-quality connecting cables (individual shielding of the safety contacts) are available in a straight version.

Suitable for direct connection to safety switch

This enabling switch can be connected directly to a safety switch (TZ...C1803) (see catalog for safety switches with metal housing).

Increased actuating force

A higher force is required on pressing through from stage 2 (enabling) to stage 3 (pressed through "panic function").

Switching elements (see also page 8)

- ▶ **2220** 2 NO/NC \ominus ¹⁾

ZSA, 3-stage function Plug connector

Dimension drawings

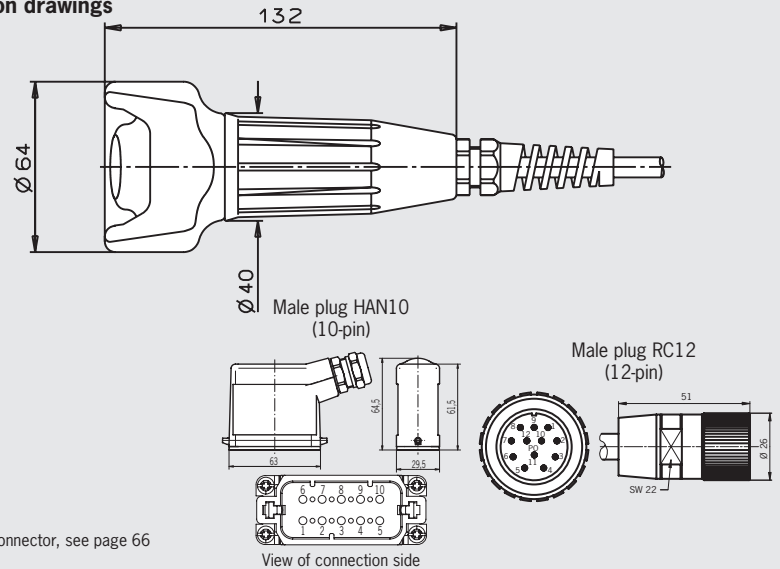

Wiring diagrams/function sequence

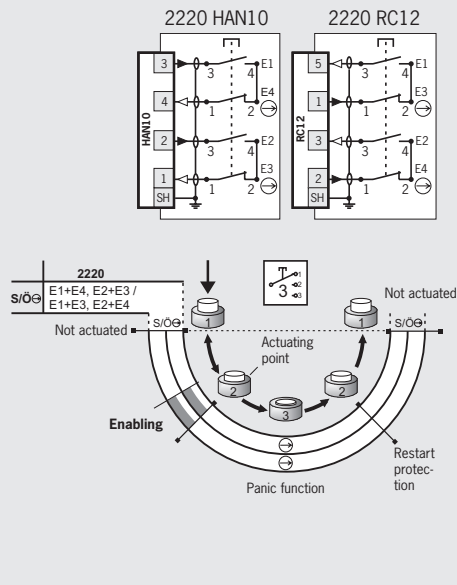

Ordering table

Design	Connection	Cable length	Version	Switching element
				2220: 2NO/NC \ominus ¹⁾
G1 3-stage	HAN10 Plug connector (10-pin)	10 m straight	Increased actuating force, shield on plug housing	077489 ²⁾ ZSA2B4G10CC1830
	RC12 Plug connector (12-pin)	5 m straight	Direct connection to TZ...C1803, shield on plug housing	092141 ^{2) 3)} ZSA092141C2038
		10 m straight	Direct connection to TZ...C1803, shield on plug housing, high actuating force	098064 ²⁾ ZSA2B4G10CC1861

1) Closed only in center position; one NO contact and one positively driven contact are combined internally.

2) No BG type examination

3) No cULus type examination

Enabling switches ZSA and ZSB

- ▶ **Housing G1**
- ▶ **3-stage function**
- ▶ **Dual-channel version**
- ▶ **Straight connecting cable**
- ▶ **Plug connector optional**
- ▶ **LED and/or pushbuttons optional**



3-stage function

Enabling function is active only in the second stage (center position, actuating point). If the pushbutton is released or pushed further (panic function), the enabling is removed (dependent on the wiring, see function sequence).

Cable

The high-quality connecting cables (individual shielding of the safety contacts) are available in a straight version.

LEDs

The LEDs are used for visual feedback direct at the enabling switch.

+ and - buttons

These pushbuttons can be configured individually. For example, for moving axes in positive or negative direction.

Switching elements (see also page 8)

- ▶ **210** 2 NO + 1 NC ⊖
- ▶ **220** 2 NO + 2 NC ⊖
- ▶ **2220** 2 NO/NC ⊖¹⁾

ZSA/ZSB, 3-stage function

Flying lead

Dimension drawings

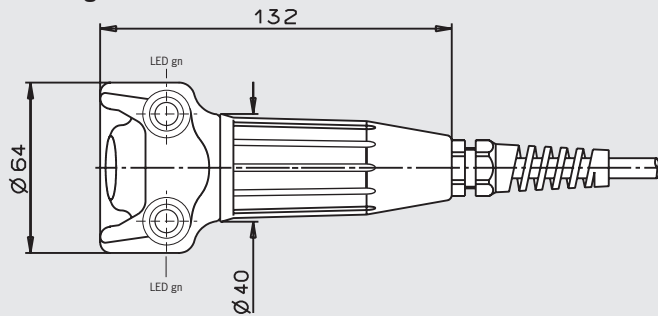

Wiring diagrams/function sequence

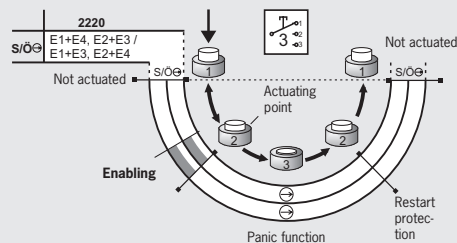
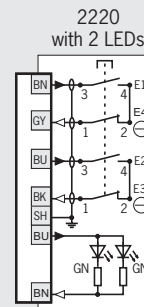

Contact
 □ open
 ■ closed
 ■ closed, enabling

Ordering table

Design	Connection/ cross-section	Cable length	Version	Switching element
G1 3-stage	Flying lead 8 x 0.34 mm ²	10 m straight	2 LEDs (gn)	2220: 2NO/NC ⊖¹⁾ 086707 ZSA086707C1983

1) Closed only in center position; one NO contact and one positively driven contact are combined internally.



ZSA/ZSB, 3-stage function Flying lead

Dimension drawings

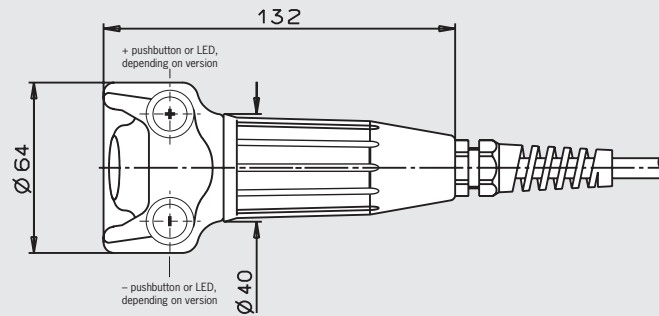

Wiring diagrams/function sequence

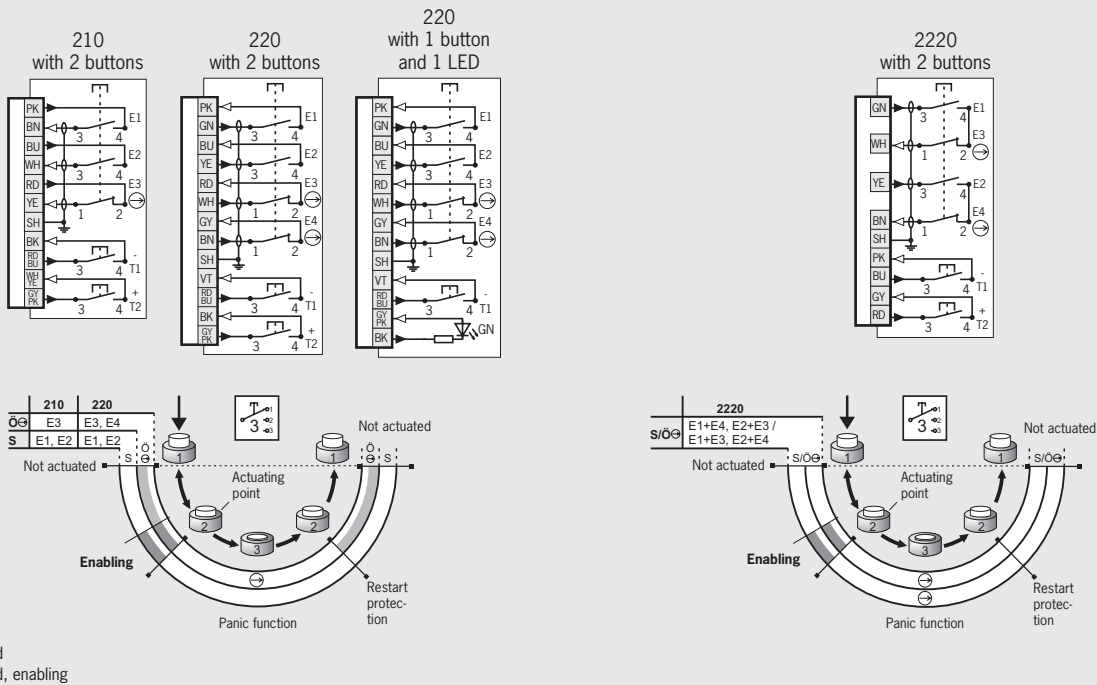

Please turn page

Ordering table

Design	Connection/ cross-section	Cable length	Version	Switching element		
				210: 2NO+1NC \ominus	220: 2NO+2NC \ominus	2220: 2NO/NC \ominus 1)
G1 3-stage	Flying lead 8 x 0.5 mm ² + 8 x 0.14 mm ²	5 m straight	1 pushbutton, 1 LED (gn)	On request	085126 2) ZSB085126	On request
		6 m straight	1 pushbutton, 1 LED (gn)	On request	110031 2) ZSB2A4G06A-C2302	On request
		5 m straight	2 pushbuttons (+ and -)	073260 ZSB2A2G05A	083317 2) ZSB083317	092378 2) ZSB092378
		10 m straight	2 pushbuttons (+ and -)	073261 ZSB2A2G10A	On request	On request
		15 m straight	2 pushbuttons (+ and -)	095612 ZSB2A2G15A	On request	On request
		20 m straight	2 pushbuttons (+ and -)	On request	096900 2) ZSB096900	On request
		8 m coiled	2 pushbuttons (+ and -)	On request	103161 2) ZSB103161	On request
		22 m coiled	2 pushbuttons (+ and -)	On request	On request	109136 ZSB2B4S22A

1) Closed only in center position; one NO contact and one positively driven contact are combined internally.

2) No BG type examination



ZSB, 3-stage function Plug connector

Dimension drawings

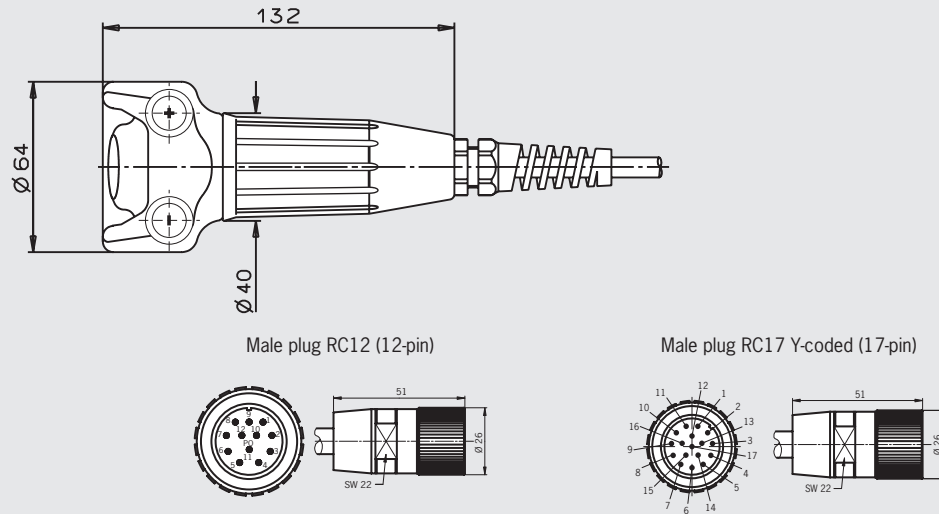

For mating connector, see page 66 and 69

View of connection side

Wiring diagrams/function sequence

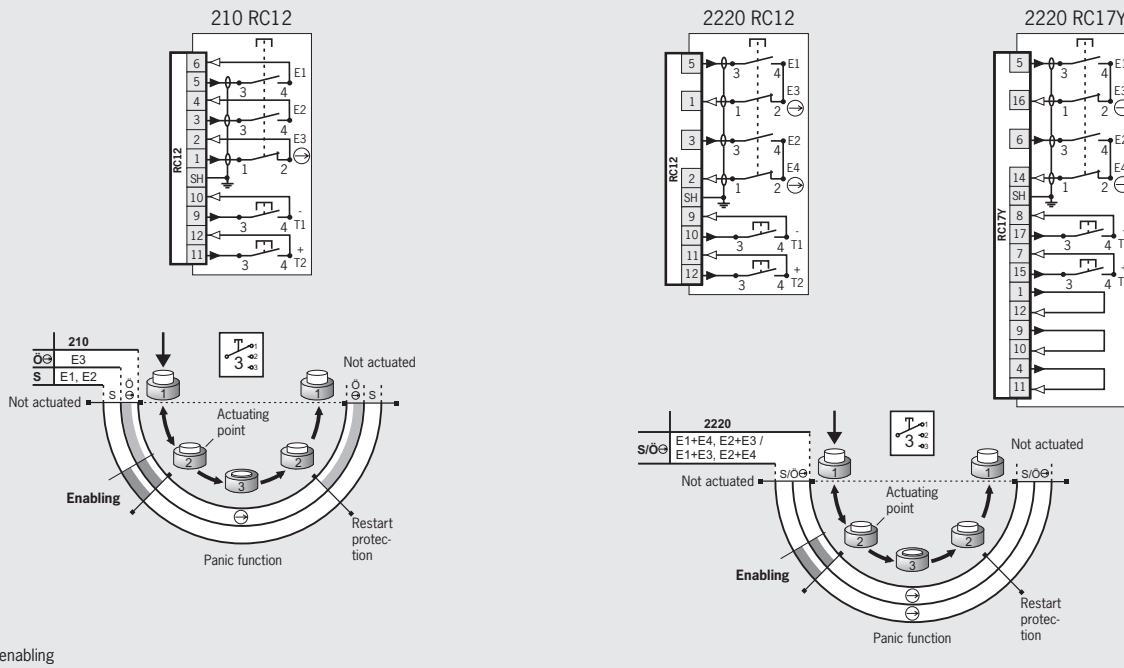

Ordering table

Design	Connection	Cable length	Version	Switching element	
				210: 2NO+1NC ⊖	2220: 2NO/NC ⊕ ¹⁾
G1 3-stage	RC12 Plug connector (12-pin)	5 m straight	2 pushbuttons (+ and -), shield on plug housing	073264 ZSB2A2G05C	On request
		5 m straight	2 pushbuttons (+ and -), direct connection TZ...C1803, shield on plug housing	On request	077040 ²⁾ ZSB077040
		10 m straight	2 pushbuttons (+ and -), shield on plug housing	073265 ZSB2A2G10C	On request
	RC17 Plug connector Y-coded (17-pin)	5 m straight	2 pushbuttons (+ and -), shield on plug housing	On request	092996 ²⁾ ZSB2B4G05C-C2044

1) Closed only in center position; one NO contact and one positively driven contact are combined internally.

2) No BG type examination



Enabling switches ZSA and ZSB

- ▶ Housing G1
- ▶ 3-stage function
- ▶ Dual-channel version
- ▶ Straight connecting cable
- ▶ Plug connector



3-stage function

Enabling function is active only in the second stage (center position, actuating point). If the pushbutton is released or pushed further (panic function), the enabling is removed (dependent on the wiring, see function sequence).

Cable

The high-quality connecting cables (individual shielding of the safety contacts) are available in a straight version.

Switching elements (see also page 8)

- ▶ **2220** 2 NO/NC ⊖¹⁾

ZSB, 3-stage function Plug connector

Dimension drawings

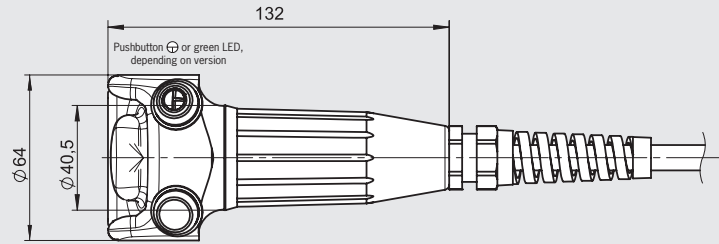

Male plug HAN10
(10-pin)

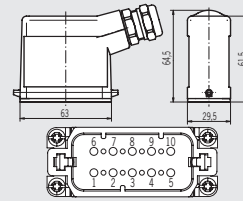

For mating connector, see page 69

View of connection side

Wiring diagrams/function sequence

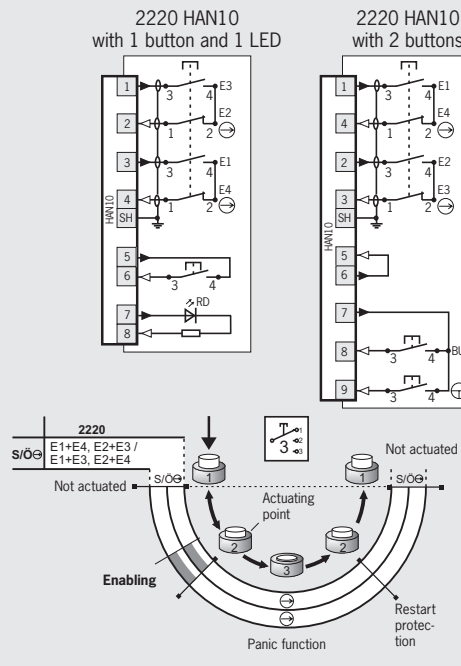

Ordering table

Design	Connection	Cable length	Version	Switching element
				2220: 2 NO/NC ⊖ ¹⁾
G1 3-stage	HAN10 Plug connector (10-pin)	3 m straight	1 blue pushbutton, 1 pushbutton ⊕	099807 ZSB2B4G03-C2176
		10 m straight	1 pushbutton, 1 green LED	106277 ZSB2B4G10C-C2281

1) Closed only in center position; one NO contact and one positively driven contact are combined internally.



Enabling switch ZSR

- ▶ 3-stage function
- ▶ Single-channel or dual-channel version
- ▶ Housing G2
- ▶ Connecting cable straight or coiled
- ▶ Including holder



3-stage function

Enabling function is active only in the second stage (center position, actuating point). If the pushbutton is released or pushed further (panic function), the enabling is removed (dependent on the wiring, see function sequence).

Cable

The high-quality connecting cables (individual shielding of the safety contacts) are available in a straight version.

Switching elements (see also page 8)

- ▶ **210** 2 NO + 1 NC ⊖
- ▶ **220** 2 NO + 2 NC ⊖

Cable lengths (coiled cable pulled out straight)

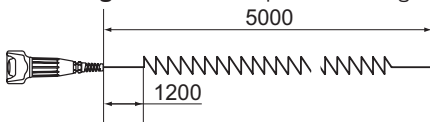

ZSR, 3-stage function

Flying lead

Dimension drawings

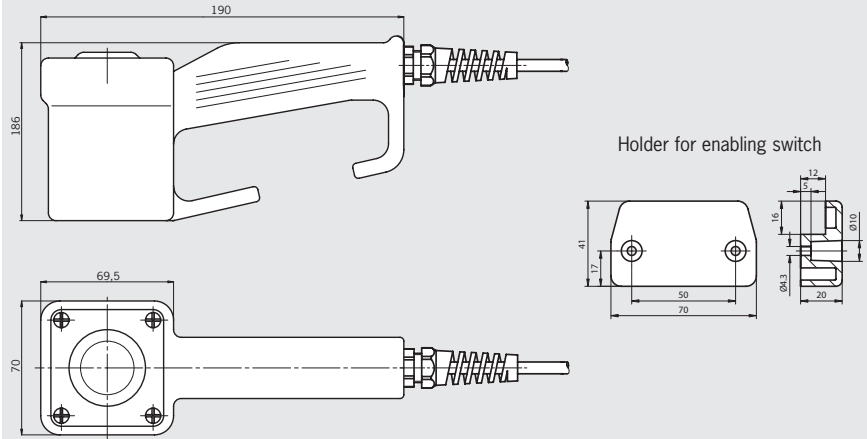

Wiring diagrams/function sequence

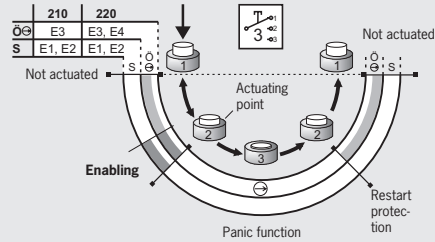
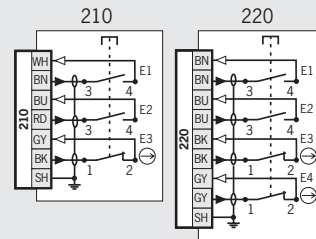

Contact
 open
 closed
 closed, enabling

Ordering table

Design	Connection/ cross-section	Cable length	Switching element	
			210: 2NO+1NC ⊖	220: 2NO+2NC ⊖
G2 3-stage	Flying lead 6 x 0.34 mm ²	10 m straight	055428 ZSR2A2G10A	-
		5 m coiled	055429 ZSR2A2S05A	-
	Flying lead 8 x 0.34 mm ²	5 m straight	-	097609 ZSR2A4G05A
		5 m coiled	-	104085 ZSR2A4S05A

1) Closed only in center position; one NO contact and one positively driven contact are combined internally.



Enabling switch ZSB

- ▶ 3-stage function
- ▶ Dual-channel version
- ▶ Housing G3
- ▶ Connecting cable straight or coiled
- ▶ Plug connector
- ▶ Two illuminated pushbuttons
- ▶ Including holder



3-stage function

Enabling function is active only in the second stage (center position, actuating point). If the pushbutton is released or pushed further (panic function), the enabling is removed (dependent on the wiring, see function sequence).

Cable

The high-quality connecting cables (individual shielding of the safety contacts) are available in a straight or coiled version.

Illuminated + and - pushbuttons

These pushbuttons can be configured individually. For example, for moving axes in positive or negative direction.

Switching elements (see also page 8)

- ▶ 220 2 NO + 2 NC ⊖
- ▶ 2220 2 NO/NC ⊖¹⁾

Cable lengths (coiled cable pulled out straight)

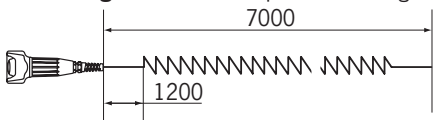

ZSB, 3-stage function Plug connector

Dimension drawings

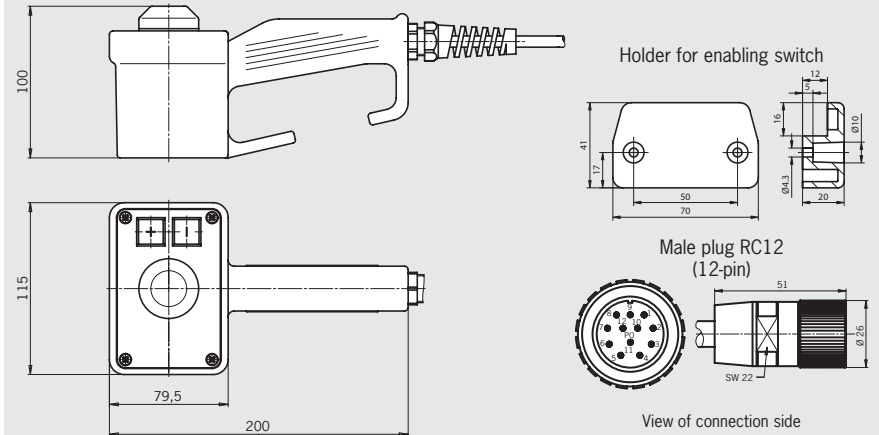

For mating connector, see page 66

Wiring diagrams/function sequence

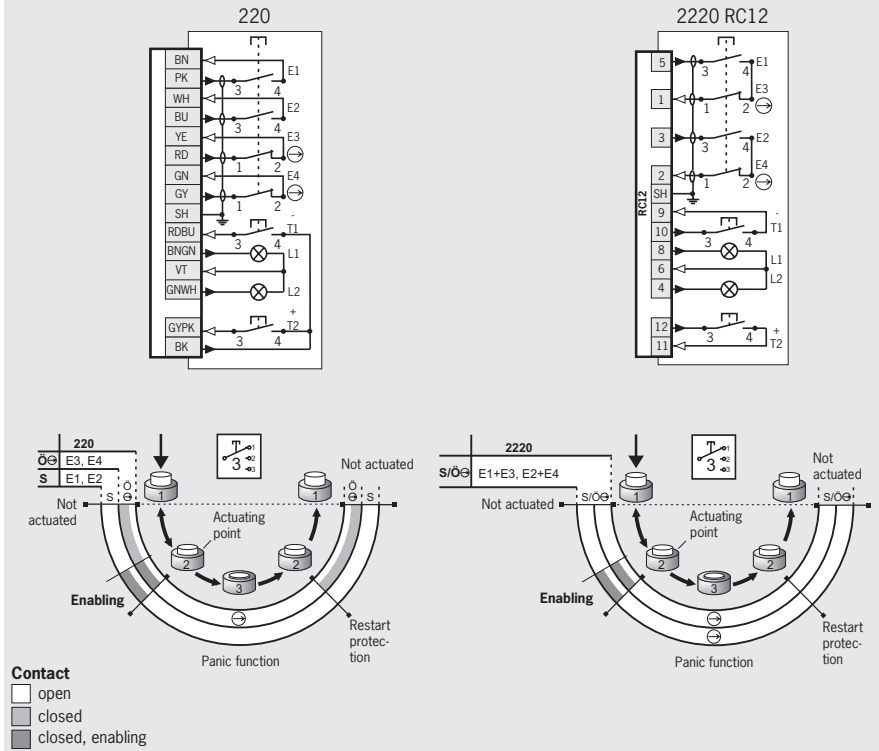

Ordering table

Design	Connection/ cross-section	Cable length	Version	Switching element	
				220: 2NO+2NC ⊖	2220: 2NO/NC ⊖ ¹⁾
G3 3-stage	Flying lead 4 x 0.5 mm ² + 4 x 0.5 mm ² + 8 x 0.14 mm ²	7 m coiled	2 illuminated pushbuttons (+ and -)	100570 ZSB100570	On request
	RC12 Plug connector (12-pin)	5 m straight	2 illuminated pushbuttons (+ and -)	-	077029 ZSB077029
		12 m straight	2 illuminated pushbuttons (+ and -)	-	085058 ZSB085058

1) Closed only in center position; one NO contact and one positively driven contact are combined internally.



Enabling switch ZSB

- ▶ 3-stage function
- ▶ Dual-channel version
- ▶ Housing G3
- ▶ Straight connecting cable
- ▶ Two illuminated pushbuttons
- ▶ Selector switch
- ▶ Including holder



3-stage function

Enabling function is active only in the second stage (center position, actuating point). If the pushbutton is released or pushed further (panic function), the enabling is removed (dependent on the wiring, see function sequence).

Cable

The high-quality connecting cables (individual shielding of the safety contacts) are available in a straight version.

Illuminated + and - pushbuttons

These pushbuttons can be configured individually. For example, for moving axes in positive or negative direction.

Selector switch (12-stage)

For the selection of different axes or ranges. All outputs are open between the switch positions on the selector switch (break-before-make switching)!

Switching elements (see also page 8)

- ▶ 2220 2 NO/NC \ominus 1)

ZSB, 3-stage function

Flying lead, key-operated rotary switch or selector switch

Dimension drawings

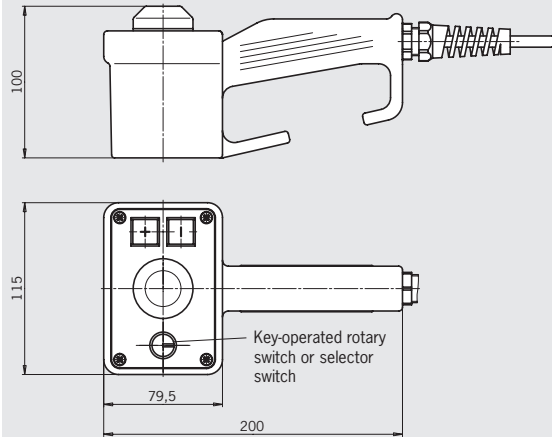

Holder for enabling switch

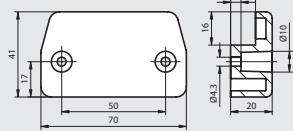

Switching table for selector switches (210 and 2220)

Pos.	BN	YE	VT	BK
	8	4	2	1
1	0	0	0	0
2	0	0	0	1
3	0	0	1	0
4	0	0	1	1
5	0	1	0	0
6	0	1	0	1
7	0	1	1	0
8	0	1	1	1
9	1	0	0	0
10	1	0	0	1
11	1	0	1	0
12	1	0	1	1

Wiring diagrams/function sequence

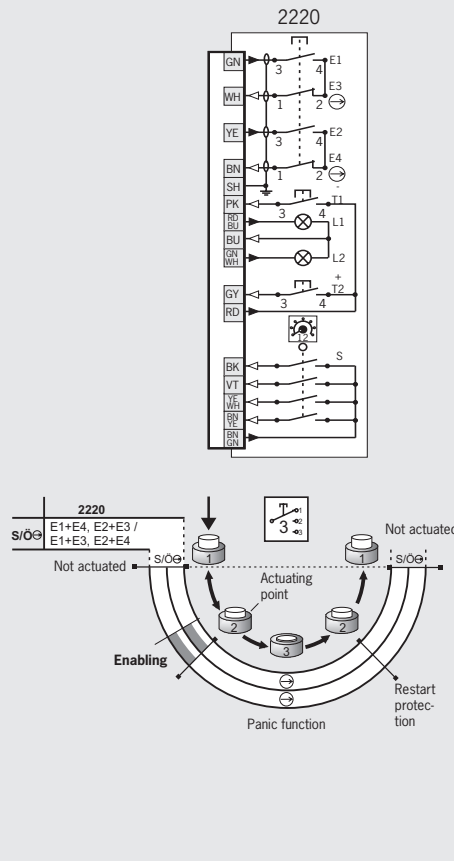

Ordering table

Design	Connection/ cross-section	Cable length	Version	Switching element
				2220: 2NO/NC \ominus 1)
G3 3-stage	Flying lead 8 x 0.5 mm ² + 8 x 0.14 mm ²	10 m straight	2 illuminated pushbuttons (+ and -), 1 selector switch	087821 ZSB087821

1) Closed only in center position; one NO contact and one positively driven contact are combined internally.



Enabling switch ZSB

- ▶ 3-stage function
- ▶ Dual-channel version
- ▶ Housing G3
- ▶ Straight connecting cable
- ▶ Plug connector
- ▶ Two illuminated pushbuttons
- ▶ Key-operated rotary switch
- ▶ Including holder



3-stage function

Enabling function is active only in the second stage (center position, actuating point). If the pushbutton is released or pushed further (panic function), the enabling is removed (dependent on the wiring, see function sequence).

Cable

The high-quality connecting cables (individual shielding of the safety contacts) are available in a straight version.

Illuminated + and - pushbuttons

These pushbuttons can be configured individually. For example, for moving axes in positive or negative direction.

Key-operated rotary switch

For individual use, e.g. as operating mode selector.

Switching elements (see also page 8)

- ▶ **210** 2 NO + 1 NC ⊖

ZSB, 3-stage function

Plug connector, key-operated rotary switch

Dimension drawings

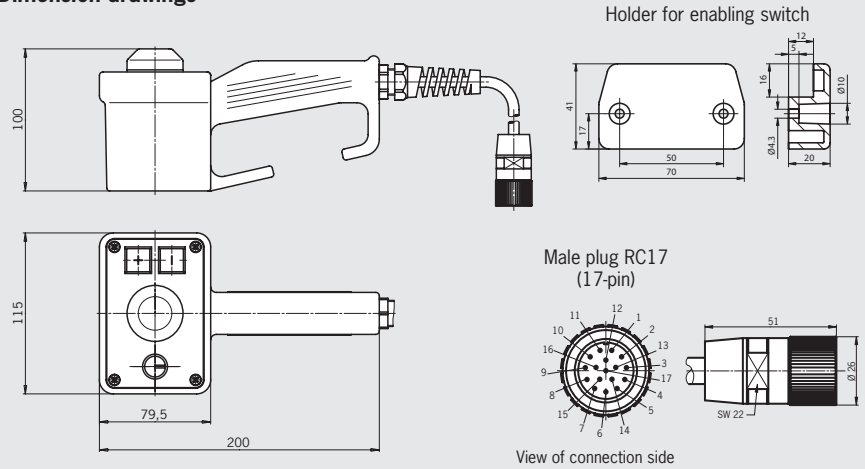

For mating connector, see page 66

Wiring diagrams/function sequence

210 with key-operated rotary switch

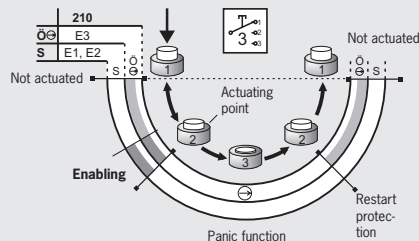
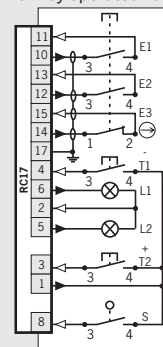

Ordering table

Design	Connection	Cable length	Version	Switching element
				210: 2NO+1NC ⊖
G3 3-stage	RC17 Plug connector (17-pin)	5 m straight	2 illuminated pushbuttons (+ and -) 1 key-operated rotary switch (1NO)	072645 ZSB072645
		12 m straight	2 illuminated pushbuttons (+ and -) 1 key-operated rotary switch (1NO)	072403 ZSB072403



Enabling switch ZSB

- ▶ 3-stage function
- ▶ Dual-channel version
- ▶ Housing G3
- ▶ Straight connecting cable
- ▶ Plug connector
- ▶ Two illuminated pushbuttons
- ▶ Key-operated rotary switch
- ▶ Emergency stop device
- ▶ Including holder



3-stage function

Enabling function is active only in the second stage (center position, actuating point). If the pushbutton is released or pushed further (panic function), the enabling is removed (dependent on the wiring, see function sequence).

Cable

The high-quality connecting cables (individual shielding of the safety contacts) are available in a straight version.

Illuminated + and - pushbuttons

These pushbuttons can be configured individually. For example, for moving axes in positive or negative direction.

Key-operated rotary switch

For individual use, e.g. as operating mode selector.

Emergency stop device

Enabling switch with dual-channel emergency stop device on the switch housing, for various wiring concepts. Red emergency stop button.

Switching elements (see also page 8)

- ▶ 2220 2 NO/NC \ominus ¹⁾

ZSB, 3-stage function

Plug connector, key-operated rotary switch, emergency stop device

Dimension drawings

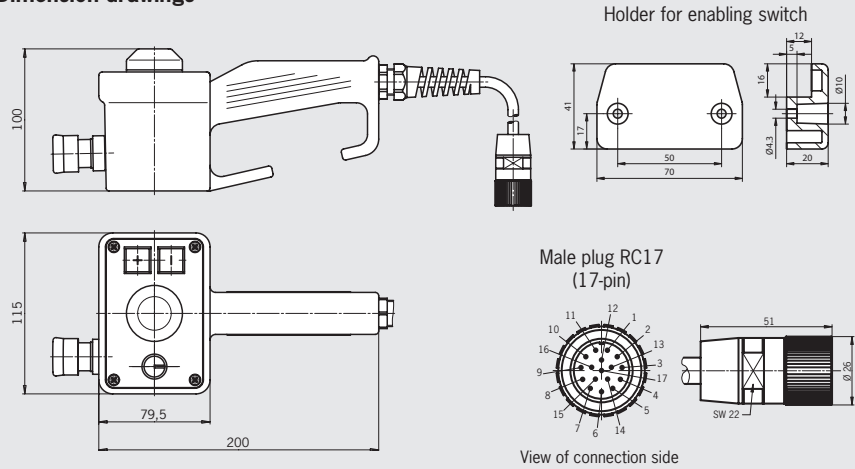

For mating connector, see page 66

Wiring diagrams/function sequence

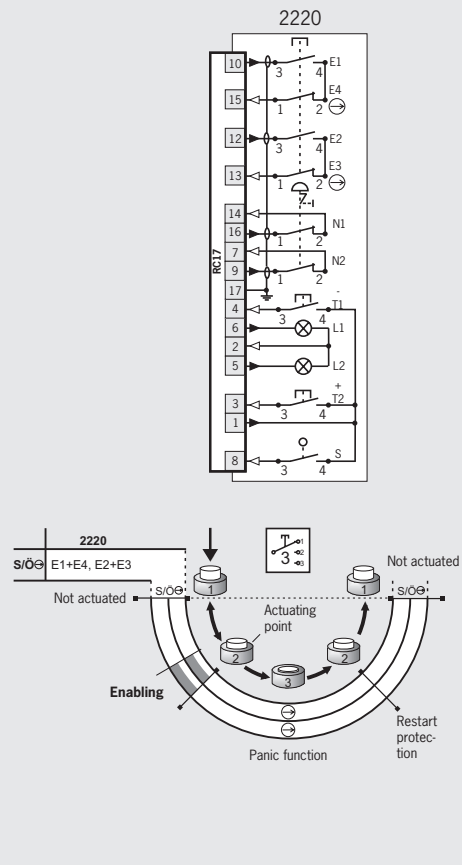

Ordering table

Design	Connection	Cable length	Version	Switching element
				2220: 2 NO/NC \ominus ¹⁾
G3 3-stage	RC17 Plug connector (17-pin)	5 m straight	2 illuminated pushbuttons (+ and -), 1 key-operated rotary switch (1NO), 1 emergency stop device	090489 ZSB090489

1) Closed only in center position; one NO contact and one positively driven contact are combined internally.



Enabling switch ZSB

- ▶ 3-stage function
- ▶ Dual-channel version
- ▶ Housing G3
- ▶ Straight connecting cable
- ▶ Plug connector
- ▶ LED indicator
- ▶ Illuminated pushbutton



3-stage function

Enabling function is active only in the second stage (center position, actuating point). If the pushbutton is released or pushed further (panic function), the enabling is removed (dependent on the wiring, see function sequence).

Cable

The high-quality connecting cables (individual shielding of the safety contacts) are available in a straight or coiled version.

LED indicator

The LED indicator is used for visual feedback directly at the enabling switch.

Illuminated pushbuttons

Additional functions can be run directly at the enabling switch using the pushbuttons.

Switching elements (see also page 8)

- ▶ 220 2 NO + 2 NC ⊕

ZSB, 3-stage function Plug connector

Dimension drawings

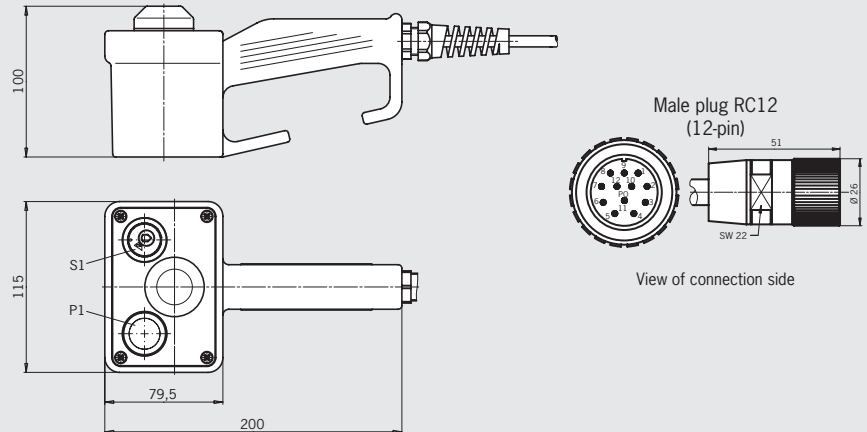

For mating connector, see page 66

Wiring diagrams/function sequence

220 RC12 ZSB122338

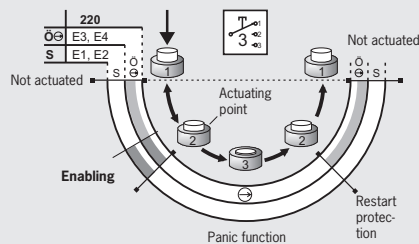
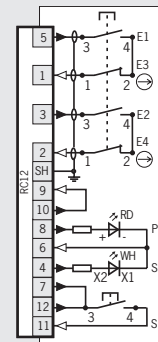

Contact
 open
 closed
 closed, enabling

Ordering table

Design	Connection	Cable length	Version	Switching element
				220: 2NO+2NC ⊕
G3 3-stage	RC12 Plug connector (12-pin)	10 m straight	1 illuminated pushbutton, 1 LED indicator	122338 ZSB122338

Selection table for enabling devices ZSG and ZSA

Design	
E	Built-in version (gray, without cable)
G1	Housing G1 (black)
Function	
2	2-stage (OFF – enabling)
Connection	
C	Tab connector, flying lead

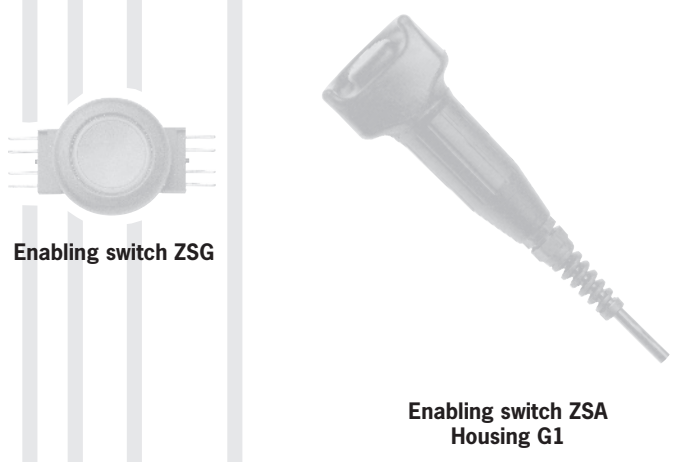

Design	Stages	Connection	Page	
E	G1	2	C	50
●	●	●	●	51

Built-in enabling device ZSG

- ▶ Gray housing
- ▶ 2-stage function
- ▶ Dual-channel version
- ▶ Suitable for installation in hand-held pendant stations HBL, for example



2-stage function ¹⁾

Enabling function is active in the second stage (pressed position). When the pushbutton is released, the enabling is removed (see function sequence).

Hand-held pendant stations HBL

See catalog for hand-held pendant stations.

Switching elements (see also page 8)

- ▶ 20 2 NO

ZSG, 2-stage function ¹⁾

Tab connector

Dimension drawings

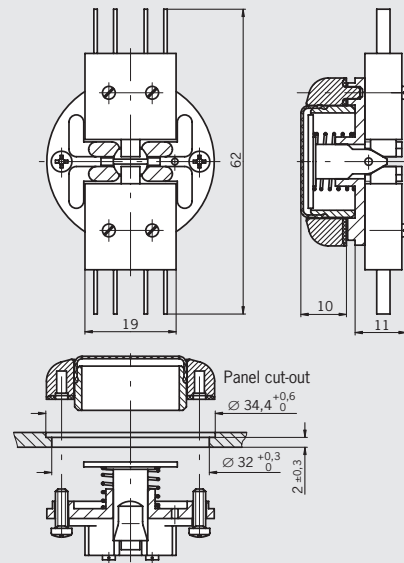

Wiring diagrams/function sequence

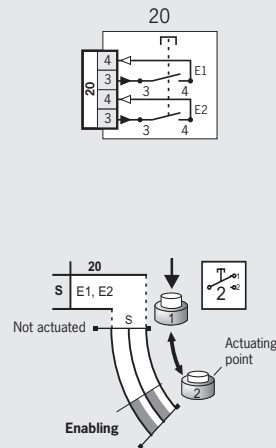

Contact
 open
 closed
 closed, enabling

Ordering table

Design	Connection	Version	Switching element
			20: 2NO
Built-in 2-stage ¹⁾ ZSG	Tab connector	Suitable for hand-held pendant stations HBL, for example	070793 ZSG1-2

¹⁾ As per VDI 2854, a device comparable to an emergency stop device must be fitted!



Enabling devices ZSA

- ▶ Housing G1
- ▶ 2-stage function
- ▶ Single-channel or dual-channel version
- ▶ Connecting cable straight or coiled
- ▶ Wall holder optional



2-stage function ¹⁾

Enabling function is active in the second stage (pressed position). When the button is released, the enabling is removed (see function sequence).

Cable

The high-quality connecting cables (individual shielding of the safety contacts) are available in a straight or coiled version.

Switching elements (see also page 8)

- ▶ **10** 1 NO
- ▶ **20** 2 NO
- ▶ **21** 2 NO + 1 NC

Cable lengths (coiled cable pulled out straight)

- ▶ Cable 6 x 0.34 mm²

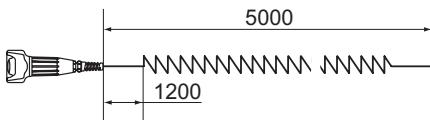

- ▶ Cable 8 x 0.34 mm²

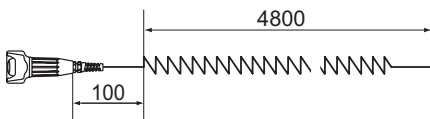

ZSA, 2-stage function ¹⁾

Flying lead

Dimension drawings

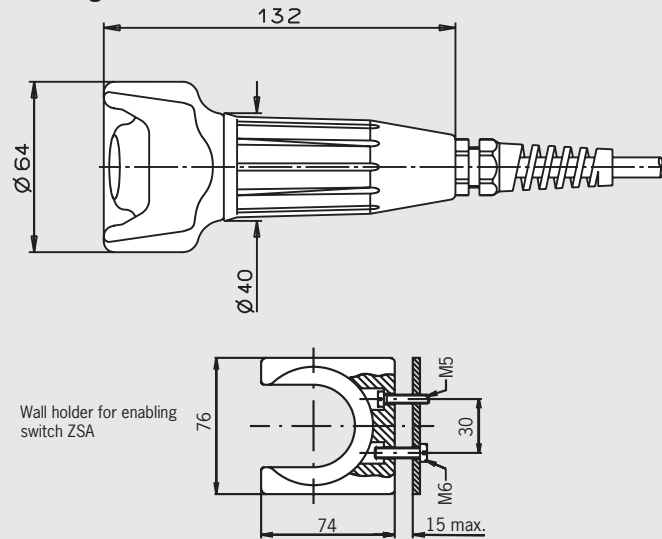

Wiring diagrams/function sequence

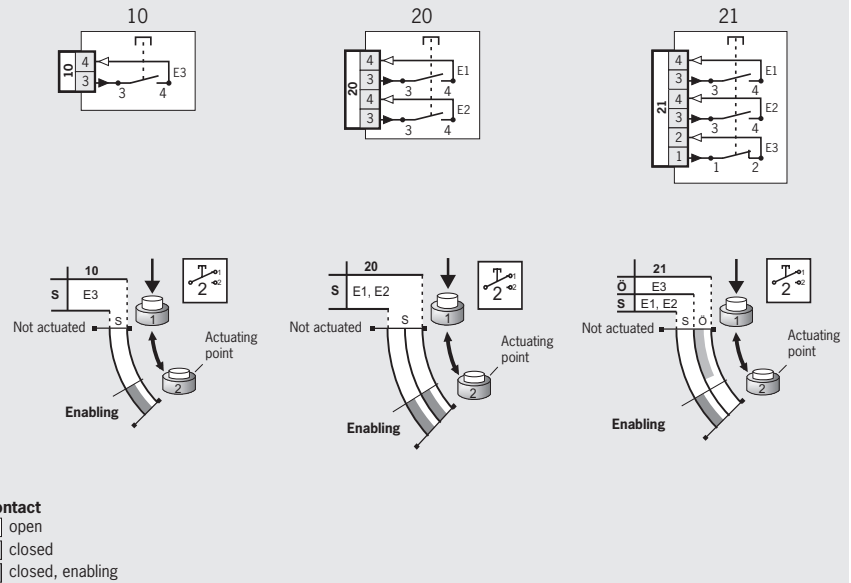

Ordering table

Design	Connection/ cross-section	Cable length	Version	Switching element		
				10: 1NO	20: 2NO	21: 2NO + 1NC
G1 2-stage ¹⁾	Flying lead 6 x 0.34 mm ²	2.5 m straight	Incl. wall holder	On request	082557 ²⁾ ZSA1A2L25AC1909	On request
		5 m coiled		On request	On request	094321 ZSA1A2S05A
	Flying lead 8 x 0.34 mm ²	5 m coiled		110755 ZSA1A5S05AC2325		

1) As per VDI 2854, a device comparable to an emergency stop device must be fitted!

2) No cULus type examination

Enabling switch/enabling device kits

Kit for enabling switch ZSM	Kit for enabling switch ZSA	Kit for enabling device ZSA	Page
●			54 - 58
	●		60
		●	61

Housing ZSM

- ▶ 3-stage function
- ▶ + and – buttons optional
- ▶ Hole for lower stop command device
- ▶ Cable gland included

3-stage function

Enabling function is active only in the second stage (center position, actuating point). If the pushbutton is released or pushed further (panic function), the enabling is removed (dependent on the wiring, see function sequence).

+ and – buttons

These buttons can be individually assigned, e.g. to move axes in positive or negative direction.

ZSM4200-106104, 3-stage function

Dimension drawing

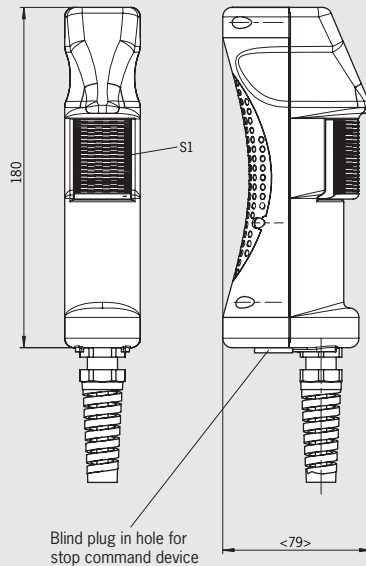

ZSM4200-106105, 3-stage function + and – buttons

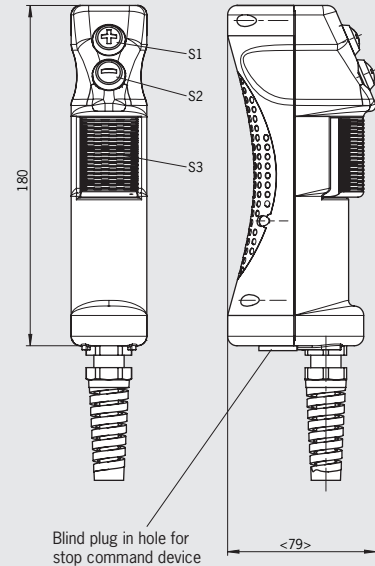

Wiring diagram/function sequence

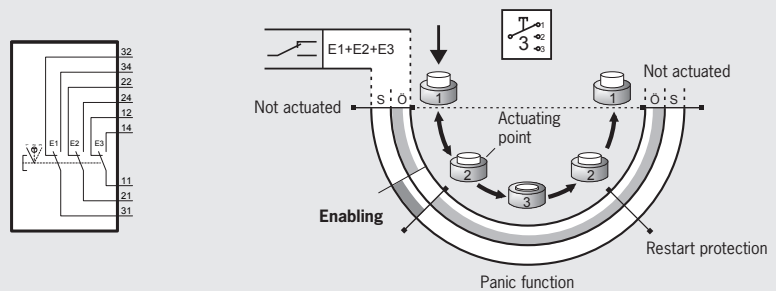

Ordering table

Design	Version	Order no./item
ZSM	Enabling switch with 3 changeover contacts (S1), cable gland included	106104 ZSM4200-106104
	Enabling switch with 3 changeover contacts (S3), +/- buttons with one NO contact each (S1/S2), cable gland included	106105 ZSM4200-106105

Accessories for installation in housing ZSM

- ▶ Machine stop
- ▶ Emergency stop device
- ▶ LED indicator

Machine stop

Machine stop (gray, with pull-to-reset and turn-to-reset button) for installation in housing ZSM, for different wiring concepts.

Emergency stop device

Two-channel emergency stop device (red, with pull-to-reset and turn-to-reset button) for installation in housing ZSM, for different wiring concepts.

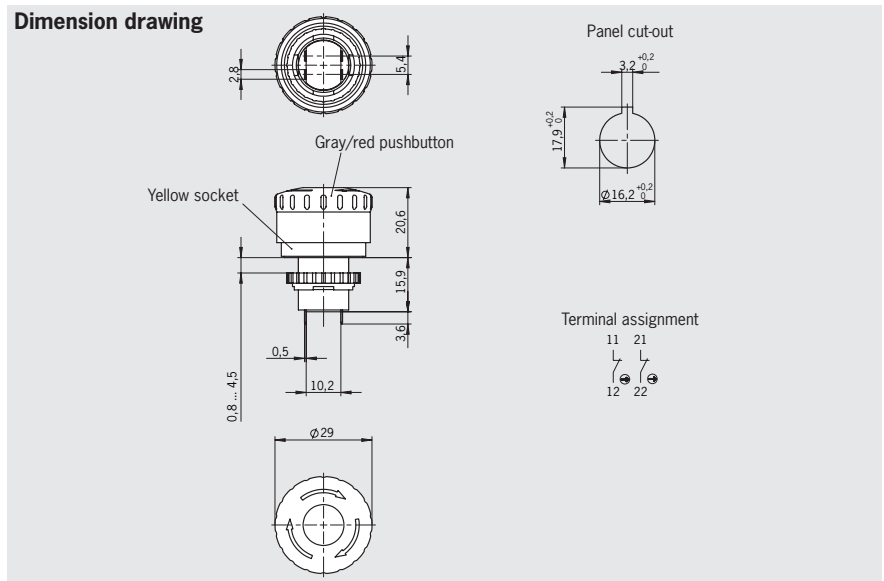

Parameter	Value
Color of actuating head	Gray/red
Color of bottom part	Yellow
Reset	Pull-to-reset and turn-to-reset button
Degree of protection	IP65
Number of switching elements	2
Contact element	2 x positively driven contact
Utilization category acc. to IEC 947-5-1	DC-13 I _e 3 A U _e 24 V

Ordering table

Designation	Version	Order no./item
Machine stop	Installation \varnothing 16 mm, gray palm button \varnothing 29 mm	116005
Emergency stop device	Installation \varnothing 16 mm, red palm button \varnothing 29 mm	106435 ES-XA1E-BV3UU02R

LED indicator

The LED indicator is used for visual feedback directly at the enabling switch.

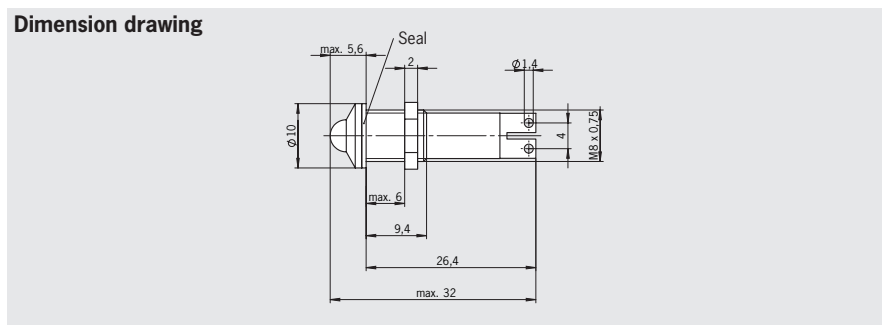

Parameter	Value
Housing	Chrome-plated
Operating voltage	24 V
Color	Yellow

Ordering table

Designation	Version	Order no./item
LED indicator	Color yellow	106347 LED indicator GE 106347

- ▶ Pushbutton
- ▶ Key-operated rotary switch

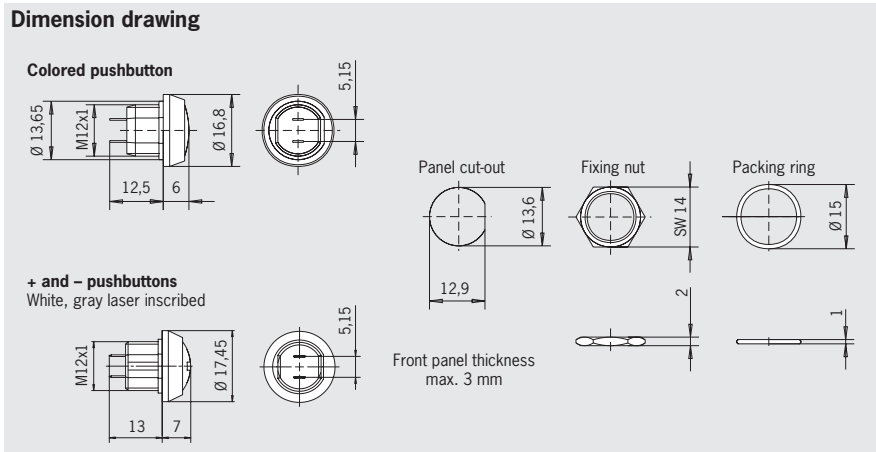

Parameter	Value
Ambient temperature	-25 ... +70 °C
Front degree of protection (integrated in front panel)	IP67
Switching principle	Pushbutton, snap-action switching element
Switching elements	1 NO contact
Switching voltage	DC 30 V
Switching current, max.	100 mA
Connection	Soldered connection

Ordering table

Designation	Button color	Pushbutton inscription	Order no.
Colored pushbutton	Black	-	083640
	Red	-	086753
	Green	-	086754
	Blue	-	086757
	White	-	086755
	Yellow	-	086756
+ and - pushbuttons White, gray laser inscribed	White	⊕	137981
	White	⊖	137984

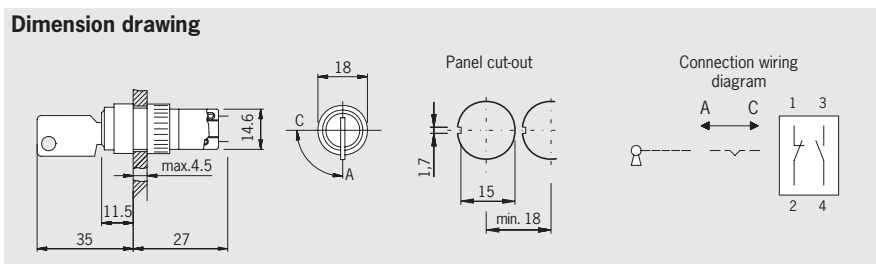

Parameter	Value
Ambient temperature	-25 ... +55 °C
Front degree of protection (integrated in front panel)/NEMA	IP65/250-12
Switching principle	Snap-action switching element
Switching elements	1 NO contact, 1 NC contact
Switching voltage	AC/DC 30 V
Switching current, max.	250 mA
Connection	Soldered connection

Ordering table

Designation	Version	Order no.
Key-operated rotary switch	Key removable in both positions	083639
Replacement key	For key-operated rotary switch 083639	092386

► Selector switch 1 of X

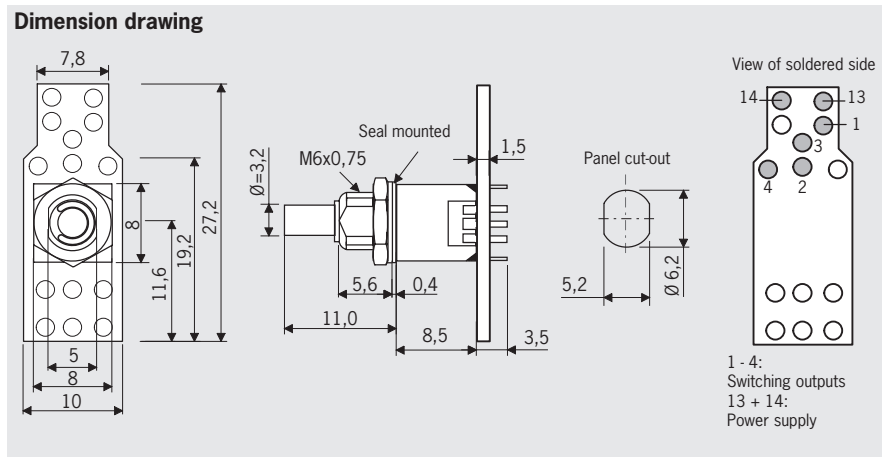

Circuit diagrams switch 1 of X

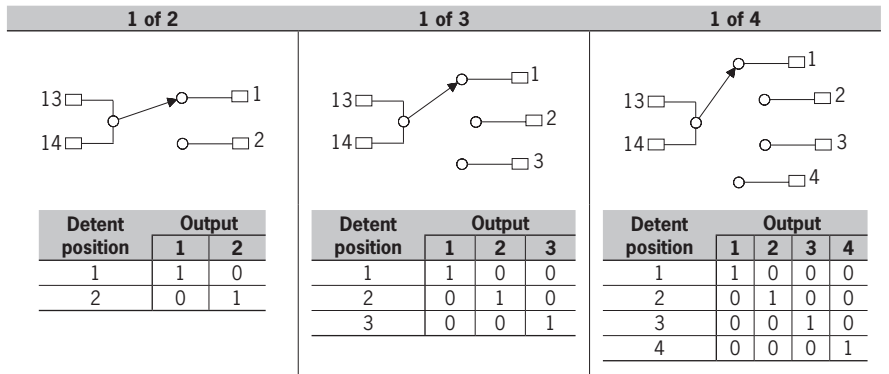

Technical data

Parameter	Value
Front degree of protection (integrated in front panel)	IP67
Center point fixing	M6 x 0.75
Detent positions	2, 3, 4 depending on item
Detent angle	30°
Output code	1 of 2, 1 of 3, 1 of 4
Breaking capacity, max.	0.2 VA
Switching voltage, max.	25 V AC/DC
Connection	Soldered connection on printed circuit board
Soldering time, max.	≤ 5 (at t ≤ 260 °C)

Ordering table

Designation	Version	Detent angle	Order no.
Selector switch 1 of X	2 detent positions, 1 of 2, break-before-make ¹⁾	30°	097026
	3 detent positions, 1 of 3, break-before-make ¹⁾	30°	097027
	4 detent positions, 1 of 4, break-before-make ¹⁾	30°	097028

1) Break-before-make: all outputs are open between the switch positions.

- ▶ Gray code selector switch
- ▶ Rotary knob for selector switch

Code table for switches with Gray code

Detent position	Output			
	D	C	B	A
1	0	0	0	0
2	0	0	0	1
3	0	0	1	1
4	0	0	1	0
5	0	1	1	0
6	0	1	1	1
7	0	1	0	1
8	0	1	0	0
9	1	1	0	0
10	1	1	0	1
11	1	1	1	1
12	1	1	1	0
13	1	0	1	0
14	1	0	1	1
15	1	0	0	1
16	1	0	0	0

Connections A - D: switching outputs
Connections 1 - 3: power supply

Dimension drawing

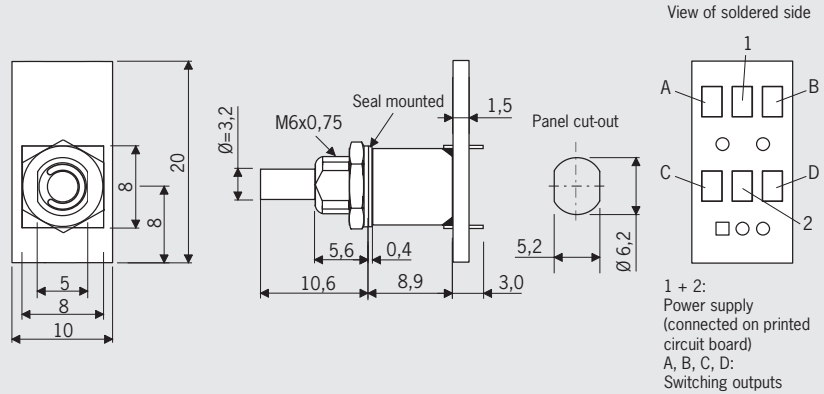

Technical data

Parameter	Value
Front degree of protection (integrated in front panel)	IP67
Center point fixing	M6 x 0.75
Detent positions	5, 6, 7, 8, 12 or 16 depending on item
Detent angle	22.5°
Output code	Gray code
Breaking capacity, max.	0.2 VA
Switching voltage, max.	25 V AC/DC
Connection	Soldered connection on printed circuit board
Soldering time, max.	≤ 5 (at t ≤ 260 °C)

Ordering table

Designation	Version	Detent angle	Order no.
Selector switch Gray code	5 detent positions, Gray code, make-before-break ¹⁾	22.5°	097029
	6 detent positions, Gray code, make-before-break ¹⁾	22.5°	097030
	7 detent positions, Gray code, make-before-break ¹⁾	22.5°	097031
	8 detent positions, Gray code, make-before-break ¹⁾	22.5°	097032
	12 detent positions, Gray code, make-before-break ¹⁾	22.5°	097033
	16 detent positions, Gray code, make-before-break ¹⁾	22.5°	097034

Dimension drawing

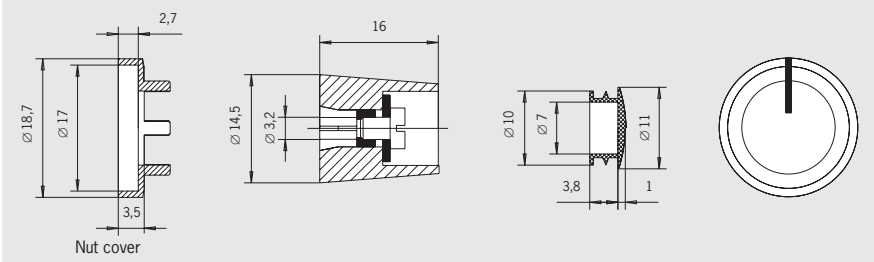

Ordering table

Designation	Version	Order no.
Rotary knob	Matt black with a marking, collet mounting for axis 3.2 mm	097141

1) Make-before-break: the corresponding outputs are connected between the switch positions.

► Straight and coiled connecting cable

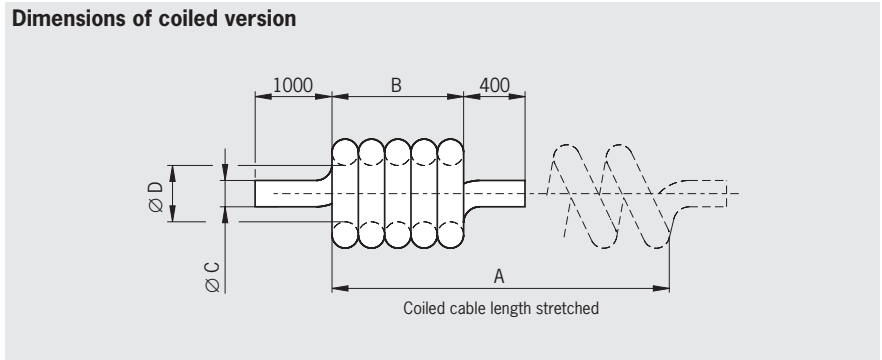
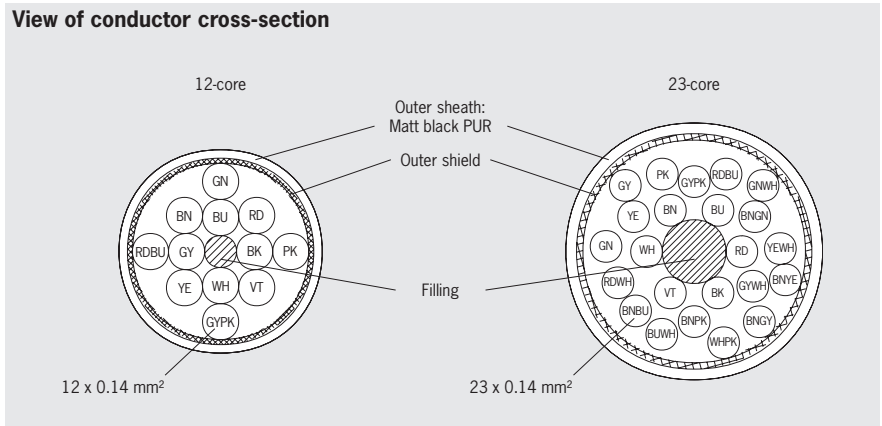

Parameter	Value
Cable resistance	$\leq 145 \Omega/\text{km}$
Test voltage, core/core	1.0 kV _{rms}
Test voltage, core/shield	1.0 kV _{rms}
Insulation resistance	≥ 200
Operating temperature	-10 ... +70 °C
Bending radius	once $\geq 10 \times$ cable diameter several times $\geq 15 \times$ cable diameter

Ordering table

Item	Cable length [mm]	A [mm]	B [mm]	$\varnothing C$ [mm]	$\varnothing D$ [mm]	Order no.
12-core, coiled cable	3,900	Approx. 2,500	550 ± 20	6 ± 0.3	8 ± 2	086721
12-core, coiled cable	5,400	Approx. 4,000	880 ± 20	6 ± 0.3	8 ± 2	086722
12-core, straight cable	3,500	-	-	-	-	087379
12-core, straight cable	5,000	-	-	-	-	087380
12-core, straight cable	10,000	-	-	-	-	087381
23-core, coiled cable	3,900	Approx. 2,500	550 ± 20	7.5 ± 0.3	10 ± 2	087408
23-core, coiled cable	5,400	Approx. 4,000	880 ± 20	7.5 ± 0.3	10 ± 2	087409
23-core, straight cable	3,500	-	-	-	-	087382
23-core, straight cable	5,000	-	-	-	-	087383
23-core, straight cable	10,000	-	-	-	-	087384

Enabling switch kit ZSA

- ▶ Housing G1
- ▶ 3-stage function
- ▶ Single-channel or dual-channel version
- ▶ Kit without connecting cable



3-stage function

Enabling function is active only in the second stage (center position, actuating point). If the pushbutton is released or pushed further (panic function), the enabling is removed (dependent on the wiring, see function sequence).

Switching elements (see also page 8)

- ▶ **111** 1 NO + 1 NC ⊕ + 1 NC
- ▶ **210** 2 NO + 1 NC ⊕
- ▶ **220** 2 NO + 2 NC ⊕

ZSA, 3-stage function

Tab connector

Dimension drawings

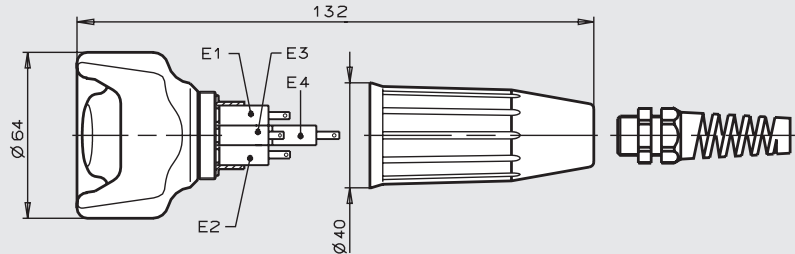

Wiring diagrams/function sequence

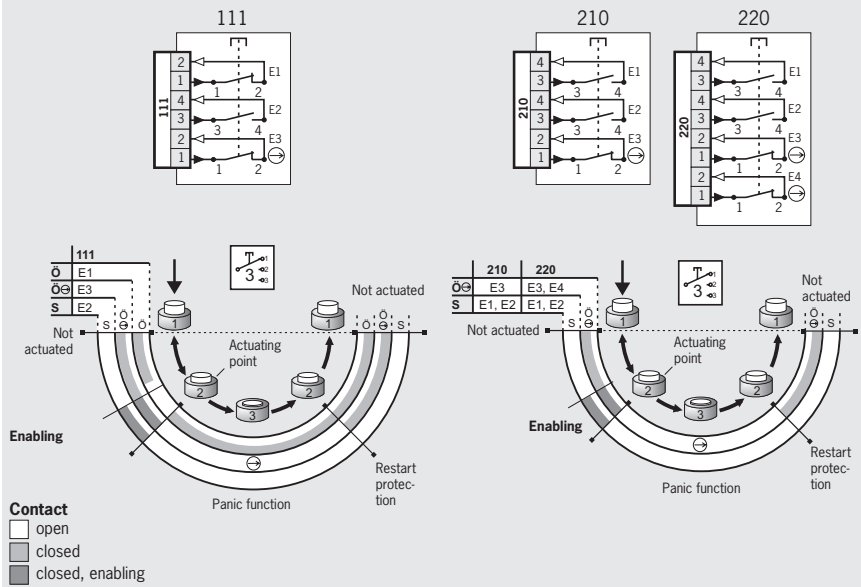

Ordering table

Design	Connection	Version	Switching element		
			111: 1NO+1NC ⊕ +1NC	210: 2NO+1NC ⊕	220: 2NO+2NC ⊕
Kit 3-stage G1	Tab connector	Without cable	070734 ZSA2-1	070735 ZSA2-2	070792 ZSA2-4

Enabling device kit ZSA

- ▶ Housing G1
- ▶ 2-stage function
- ▶ Single-channel or dual-channel version
- ▶ Kit without connecting cable



2-stage function ¹⁾

Enabling function is active in the second stage (pressed position). When the button is released, the enabling is removed (see function sequence).

Switching elements (see also page 8)

- ▶ **10** 1 NO
- ▶ **20** 2 NO
- ▶ **21** 2 NO + 1 NC

ZSA, 2-stage function ¹⁾ Tab connector

Dimension drawings

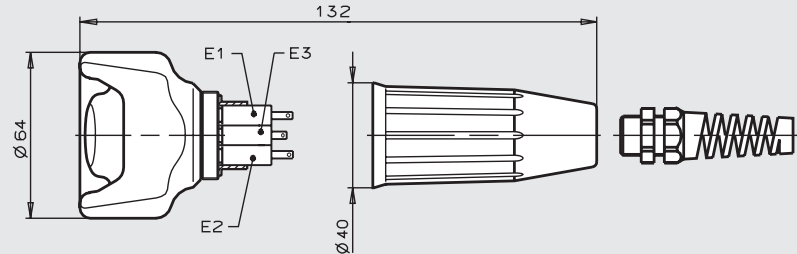

Wiring diagrams/function sequence

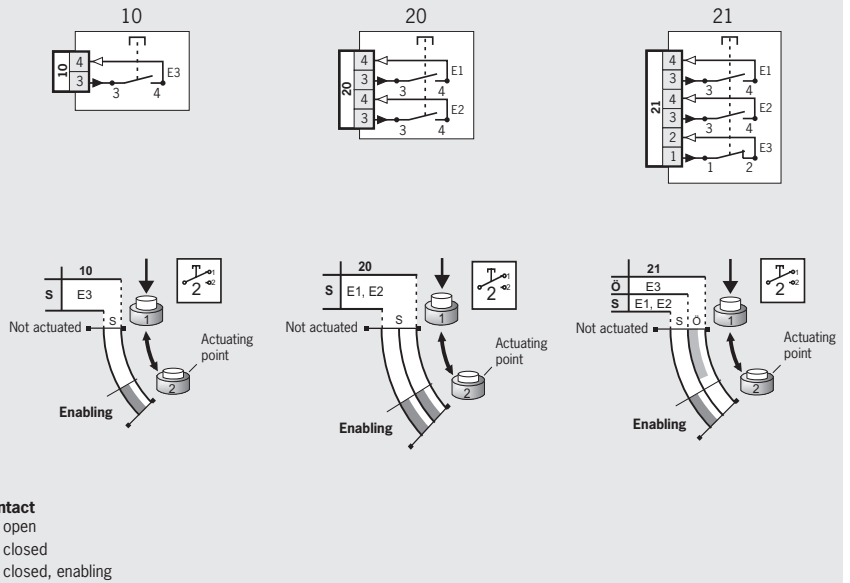

Ordering table

Design	Connection	Version	Switching element		
			10: 1NO	20: 2NO	21: 2NO + 1NC
Kit 2-stage ¹⁾ G1	Tab connector	Without cable	070750 ZSA1-1	070800 ZSA1-2	070736 ZSA1-3

¹⁾ As per VDI 2854, a device comparable to an emergency stop device must be fitted!

Selection table for accessories

Holder for hand-held enabling switches						
Actuator for type 2 safety switches NZ.VZ and TZ						
Plug connector						
		RC12		12-pin		
		RC17		17-pin		
Connecting cables						
Holder		Actuator	Plug connector		Connecting cables	Page
ZSM	ZSA		RC12	RC17		
●						64
	●	●				65
			●	●		66/ 67
					●	68

Holder for hand-held enabling switch ZSM

- ▶ Holder for hand-held enabling switch ZSM

Screw holder for enabling switch ZSM

Depending on version, the holder can be fastened to machine parts either with a magnet or two screws.

Screw holder for enabling switch ZSM

Dimension drawing

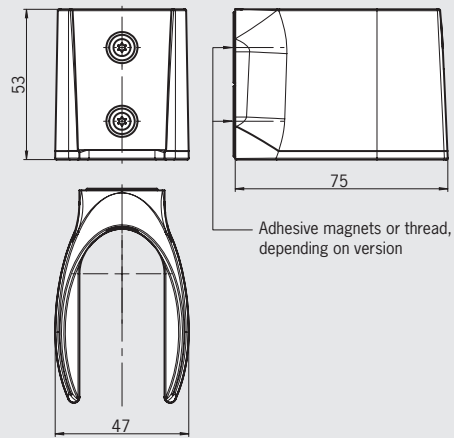

Ordering table

Designation	Version	Order no./item
Holder for enabling switch ZSM	Screw mounting	102969 Holder ZSM
	Magnet fastening	102965 Holder ZSM with magnet

Holder for hand-held enabling switches ZSA and ZSB / Actuator for type 2 safety switches NZ.VZ and TZ

- ▶ **Magnetic holder**
- ▶ **Screw holder**
- ▶ **Screw holder with cable hook**
- ▶ **Actuator for mounting on the hand-held enabling switch**

Magnetic holder for housing G1

The enabling switches can be attached at any time to any part of the machine due to the magnets fastened to the holder. In this way, the enabling switch can be positioned in the activity area as necessary.

Screw holder for housing G1

The holder can be securely fastened to parts of the machine with a wall thickness of max. 15 mm using two screws.

Screw holder for housing G1 with cable hook

A holder with an additional cable hook for hanging a wound-up cable.

Actuators for safety switches

Suitable for fitting to the hand-held enabling switch kit, for example. Safe position polling of the enabling switch can be achieved by fitting the actuator and using an appropriate safety switch (NZ.VZ or TZ). By suitable integration of this combination, the signal from the safety switch can be used, e.g. as an operating mode selector, when the actuator is removed (removal of the enabling switch). Suitable for the kit ZSA.

Magnetic holder

Dimension drawings

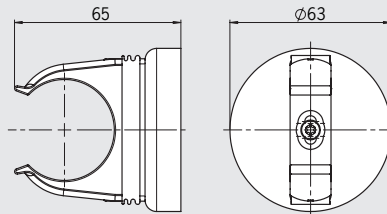

Screw holder

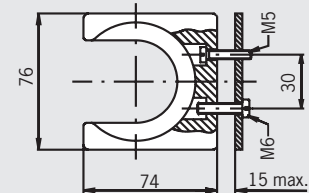

Screw holder with cable hook

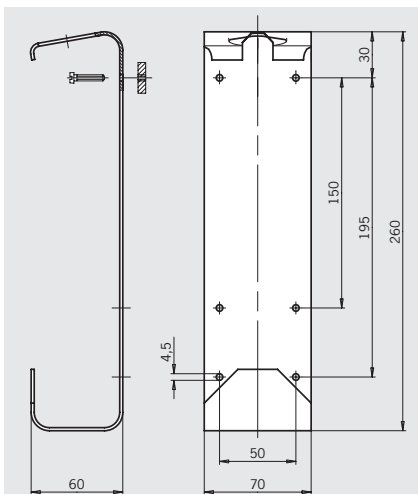

Actuator for safety switches series NZ.VZ and TZ

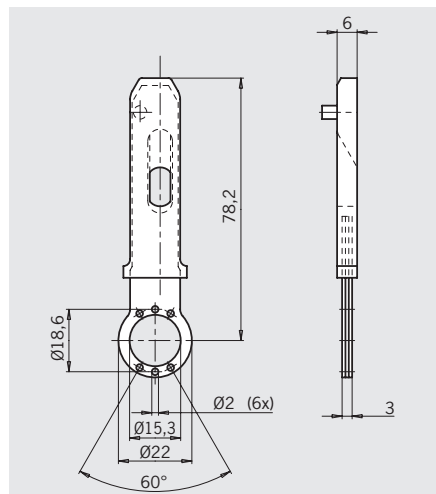

Ordering table

Designation	Version	Order no./item
Magnetic holder		059340 Magnetic holder
Screw holder	M5 x 25	052406 Holder complete
	With cable hook M4 x 20	047820 Cable holder
Actuator NZ/TZ		084833 Actuator-Z-G-C1932

Plug connector

- ▶ Female flange connector RC12
- ▶ Male plug RC12
- ▶ Blanking plug RC12
- ▶ Female flange connector RC17
- ▶ Male plug RC17
- ▶ Blanking plug RC17

Female flange connector RC12¹⁾
 For front wall mounting for connection of hand-held enabling switches. Fitted with soldered contacts. Rubber seal included.

Male plug RC12¹⁾
 For connection to enabling switches, for example.

Blanking plug RC12¹⁾
 For covering the flange connector RC12. Optionally, the customer can fit bridges to the individual contacts or use a pre-wired version (coded). Coding: bridge from pin 1 to pin 2 and from pin 9 to pin 10.

Flange connector RC17¹⁾
 For front wall mounting for connection of enabling switches. Rubber seal included. Fitted with soldered contacts.

Male plug RC17¹⁾
 For connection to enabling switches, for example.

Blanking plug RC17¹⁾
 For covering the flange connector RC17. Optionally, the customer can fit bridges to the individual contacts.

Female flange connector RC12
12-pin

Dimension drawings

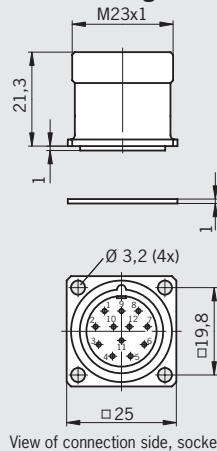

Male plug RC12
12-pin

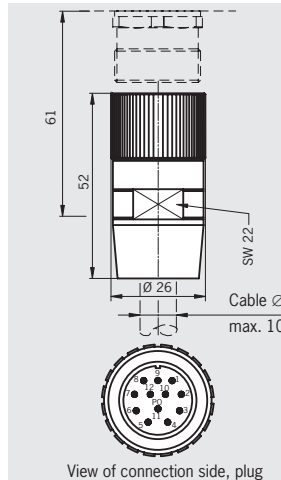

Blanking plug RC12
12-pin

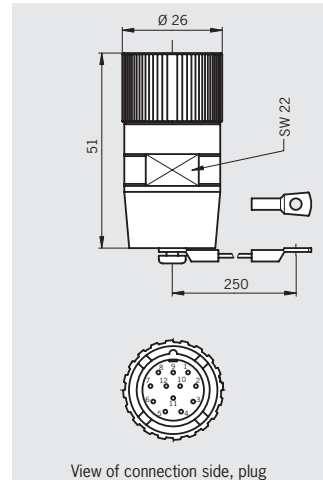

Female flange connector RC17
17-pin

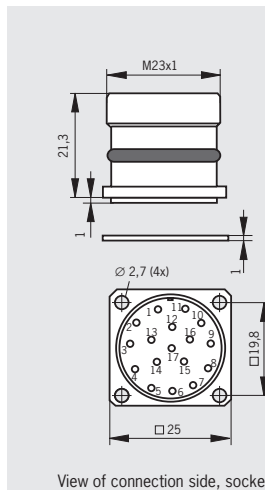

Male plug RC17
17-pin

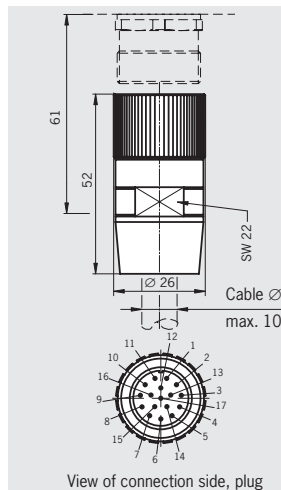

Blanking plug RC17
17-pin

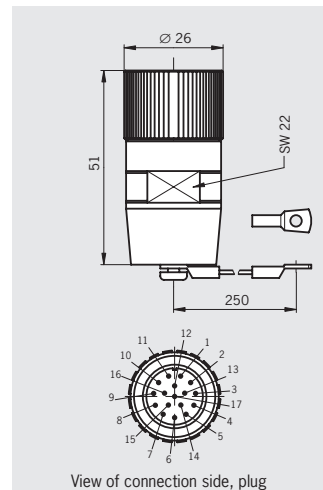

Ordering table

Designation	Connection	Version	Order no./item
RC12 12-pin	Soldered connection	Female flange connector	073290 Female flange connector, 12-pin
	Crimp contact ¹⁾	Male plug	073294 Plug connector, 12-pin
	Crimp contact ¹⁾	Blanking plug (with bridges) e.g. in combination with ZSM2104-123678	073291 Blanking plug, complete, 12-pin
	Crimp contact ¹⁾	Blanking plug (without bridges)	073293 Blanking plug, 12-pin
RC17 17-pin	Soldered connection	Female flange connector	077502 Female flange connector, 17-pin
	Crimp contact ¹⁾	Male plug	096481 Plug connector, 17-pin
	Crimp contact ¹⁾	Blanking plug (without bridges)	096159 Blanking plug, 17-pin

For information on crimp contacts, see page 69.

1) Crimp contacts are included.

Plug connector

- ▶ Female plug RC17
- ▶ Male flange connector RC17

Female plug RC17

Female plug for hand-held enabling switch.

Male flange connector RC17

For connection, e.g. to enabling switches, pre-assembled.

Female plug RC17
17-pin

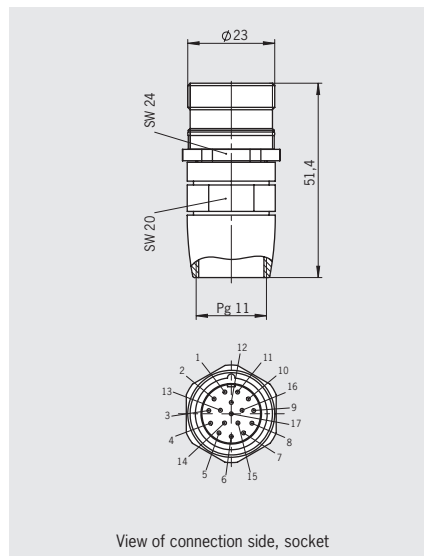

Male flange connector RC17
17-pin

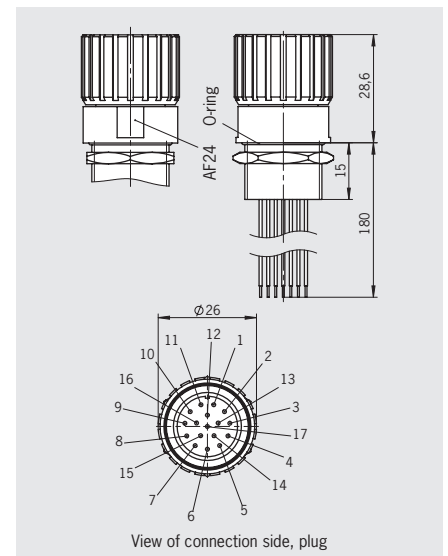

Parameter	Value	
Housing material	Metal	
Number of pins	17 (shield on the housing)	
	Male plug	Flange connector
Cable diameter, max.	10 mm	-
Connection	Crimp contacts 0.14 ... 0.56 mm ²	Soldered connections 1.0 mm ²
Rated voltage, max.	230 V AC/DC	
Degree of protection (inserted)	IP67	

Ordering table

Item	Connection	Version	Order no./item
RC17 17-pin	Crimp contact	Female plug	106349 ¹⁾ Female plug, 17-pin
		Male flange connector with wires, pre-assembled	106360 Male flange connector, 17-pin

For information on crimp contacts, see page 69.

1) Crimp contacts are included.

Connecting cables

Connecting cable for enabling switch ZSM with plug connector RC17

Connecting cable for enabling switch ZSM with plug connector RC17

The high-quality connecting cable for the ZSM2300-106374 can be plugged directly into the device.

The corresponding male flange connector is available for the ZSM kit (see page 67).

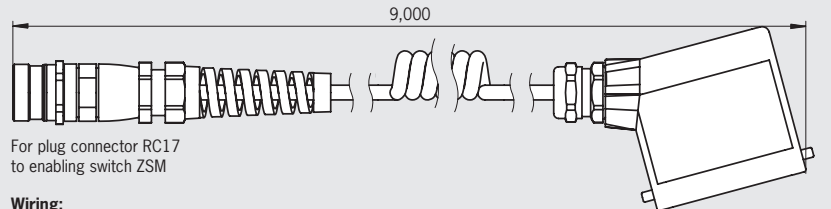

For plug connector RC17 to enabling switch ZSM

Wiring:
Pin 1 to pin 10 are wired through 1:1.

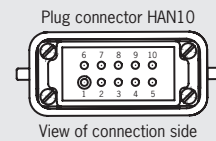

Ordering table

Designation	Version	Order no./item
Connecting cable for enabling switch ZSM with plug connector RC17	Coiled, length 9.0 m	106392 Coiled cable with plug connector, 9 m

Connecting cable for enabling switch ZXE-111276

4-pin, tab connector

Connector assignment

Pin	Cross-section [mm ²]	Conductor coloring
1	0.34	RD
2	0.34	BK
3	0.34	OR
4	0.34	BN

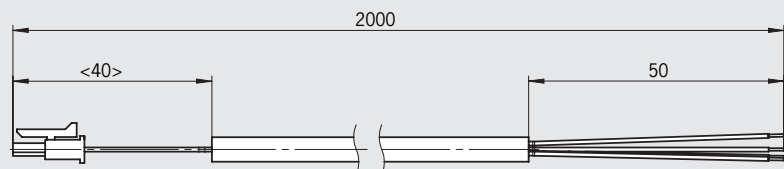
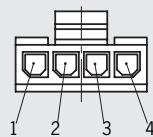

Ordering table

Designation	Connection	Order no./item
Connecting cable for enabling switch ZXE-111276	Tab connector	115123 Connecting cable for enabling switch ZXE-111276

List of plug connector suppliers

We provide no guarantee for the completeness and correctness of the ordering data given. The data was valid in February 2021. The related manufacturers reserve the right to make changes without notice. The plug connectors and accessories listed are also available from other manufacturers.

► Plug connectors and accessories

For plug connector	Function	Manufacturer's designation	
SVM5 5 pins	Female plug M12	99-1436-812-05 Cable socket	Binder www.binder-conector.de
	Female flange connector M12	09-3442-700-05 Flange connector with flexible wires	
	Blanking plug M12	08-2610-000-000 Protective cap for socket with retaining strap	
HAN10 10 pins + PE	Flange connector, 1 cable exit	19 20 010 0251 Socket housing, 1 cable exit	Harting www.harting.com
	Socket contacts (installation for flange connector)	09 20 010 3101 Socket contact insert crimp connection	
	Socket contacts for crimping	09 33 000 6220 Socket crimp contacts, 0.5 mm ²	
	Blanking plug	09 20 010 5425 Cover	
HAN Q17 10 pins + PE	Flange connector	09 12 008 0303 Metal mounting housing	PhoenixContact www.phoenixcontact.com
	Socket contact (installation for flange connector)	09 12 017 3101 Socket contact insert crimp connection	
	Socket contacts for crimping	09 15 000 6204 Socket crimp contacts, 0.14 ... 0.37 mm ²	
RC17-Y coded 17 pins	Female flange connector, solderable to male plug RC17	RC-17S1Y122000 Flange plug connector, 17-pin	

► Crimp and extraction tools

For plug connector	Function	Manufacturer's designation	
RC12 and RC17	Crimp tool	RC-Z2504 Crimp pliers for turned contacts	PhoenixContact www.phoenixcontact.com
	Extraction tool	RC-Z2494 Extraction tool/insertion tool	

Overview

Wiring diagrams ZSM

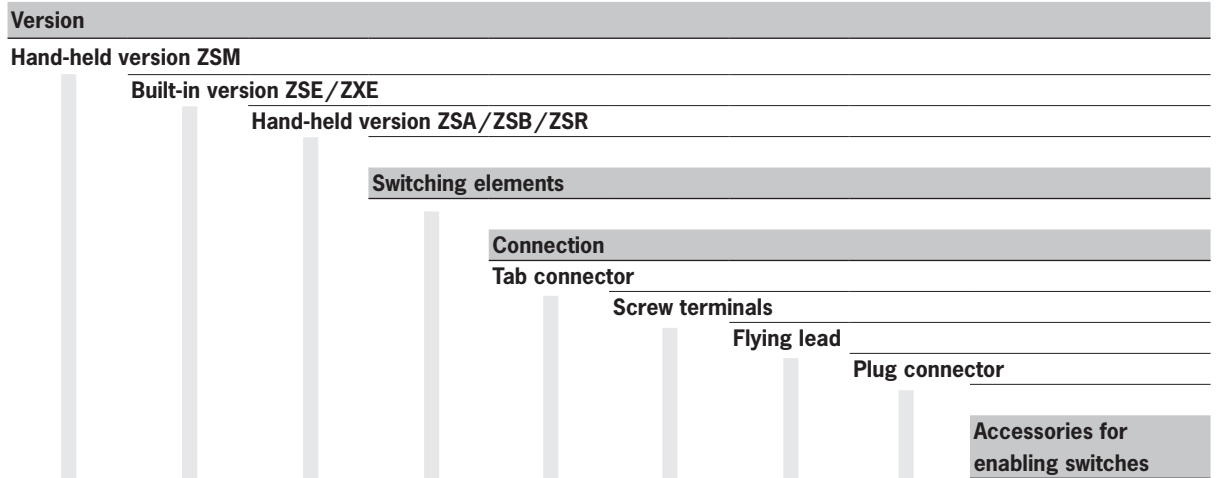

Wiring diagrams ZSM	Version			Switching elements	Connection				Accessories	Page
	ZSM Hand-held	ZSE/ZXE Built-in	ZSA/ZSB/ZSR Hand-held		Tab connector	Screw terminals	Flying lead	Plug connector		
•										72 - 79
	•									80/81
		•								82
			•							82
				•						82
					•					83
						•				83
							•			83
								•		83/78
									•	84/84

Wiring diagrams

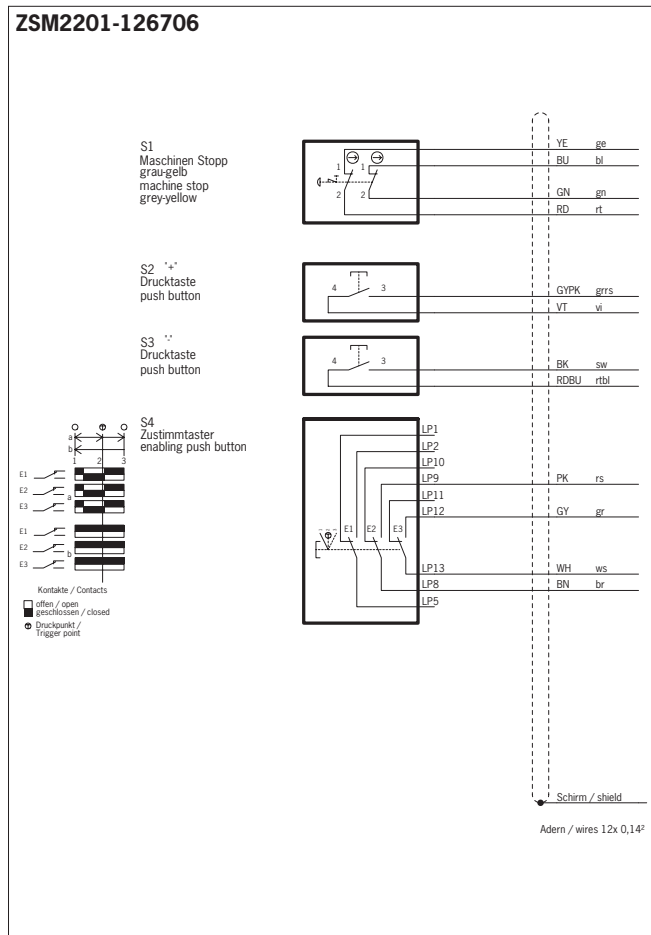
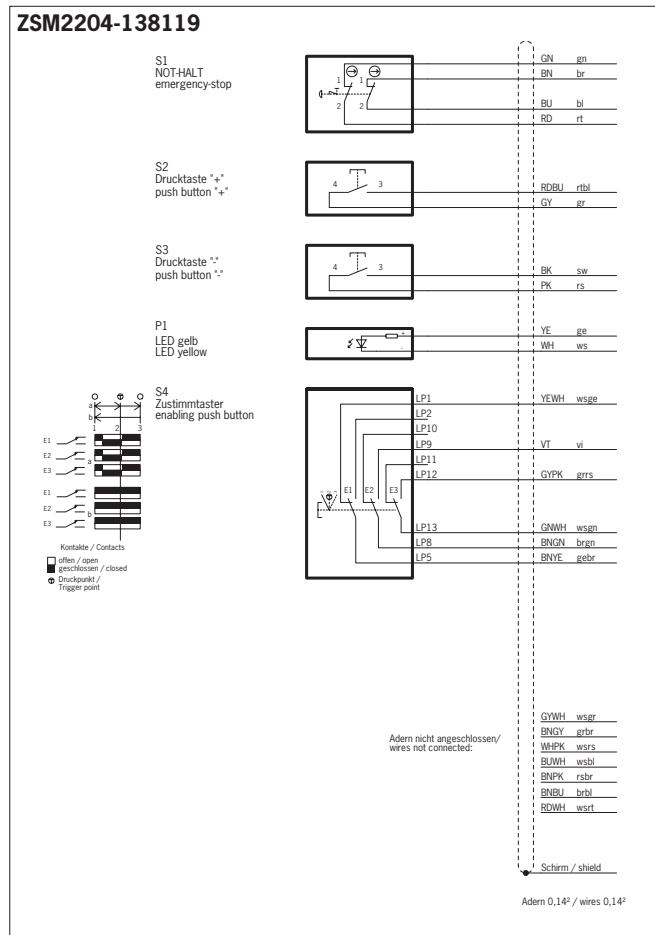
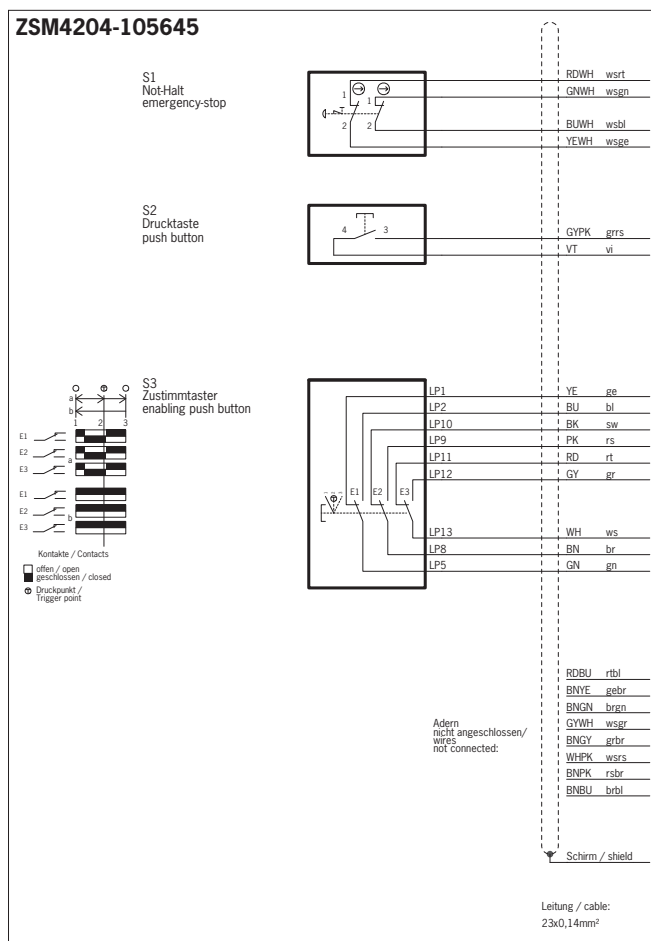
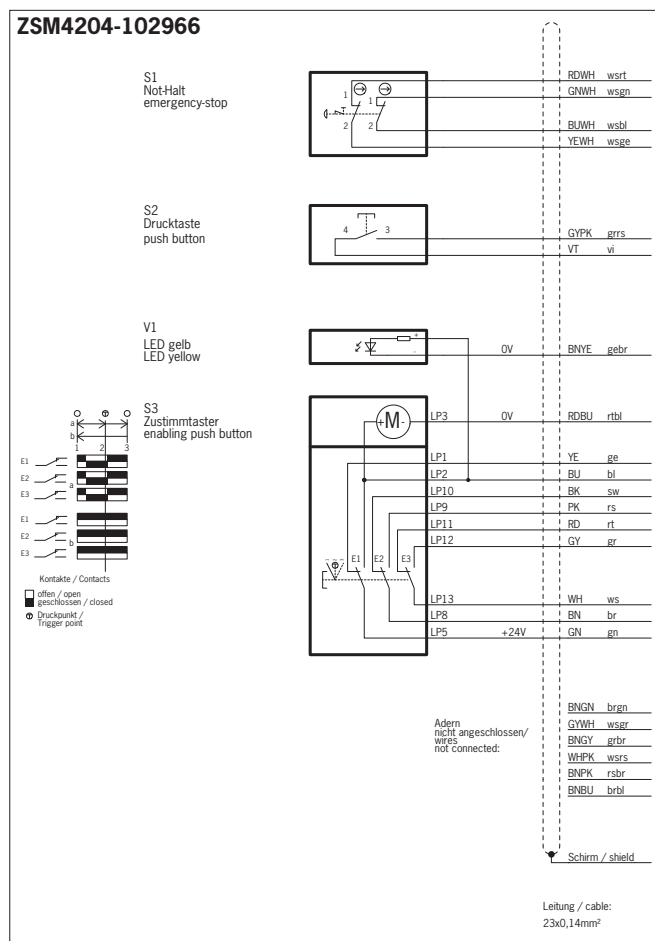

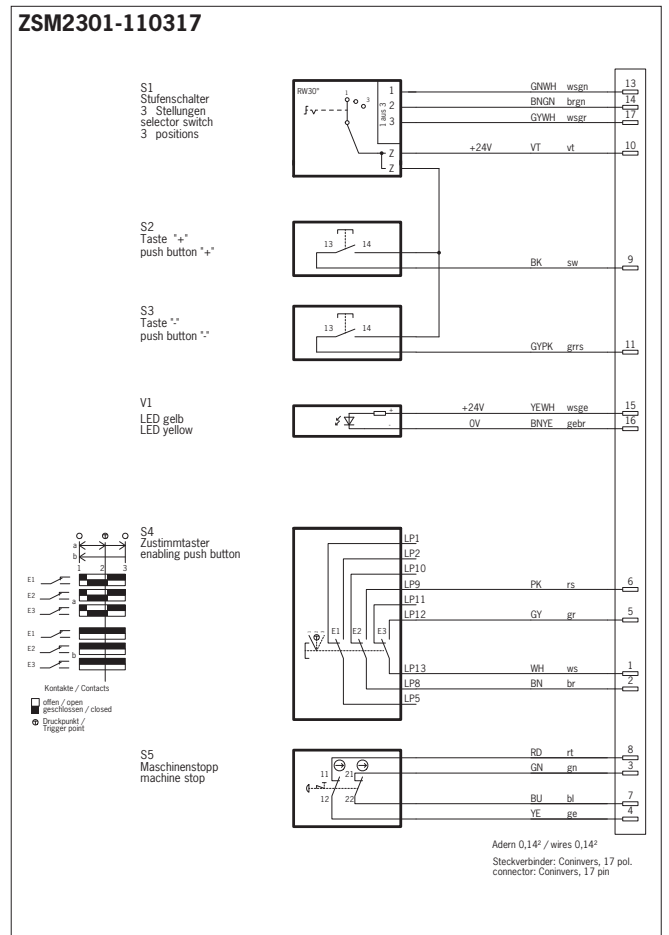
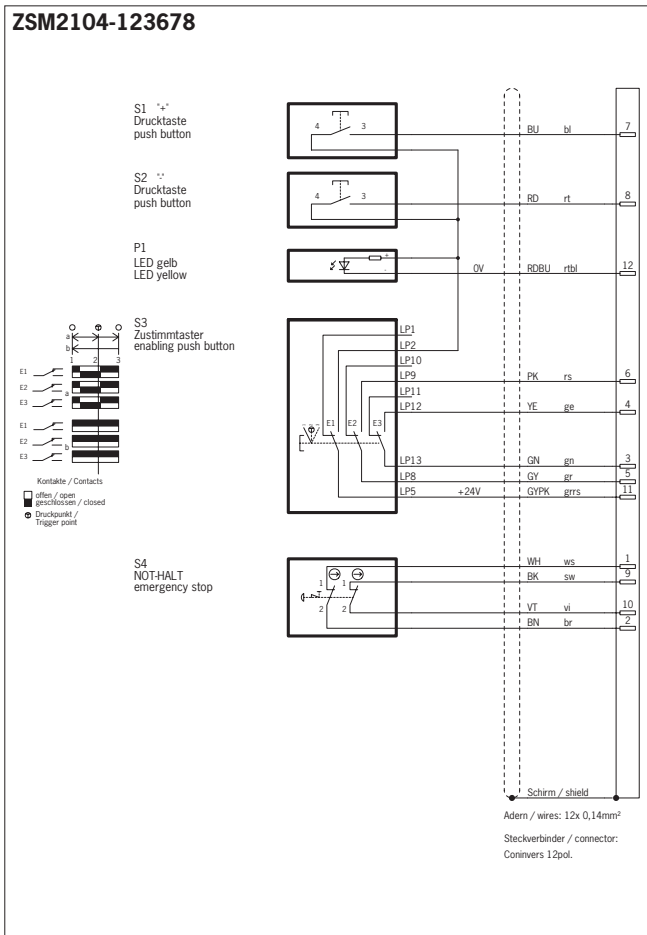
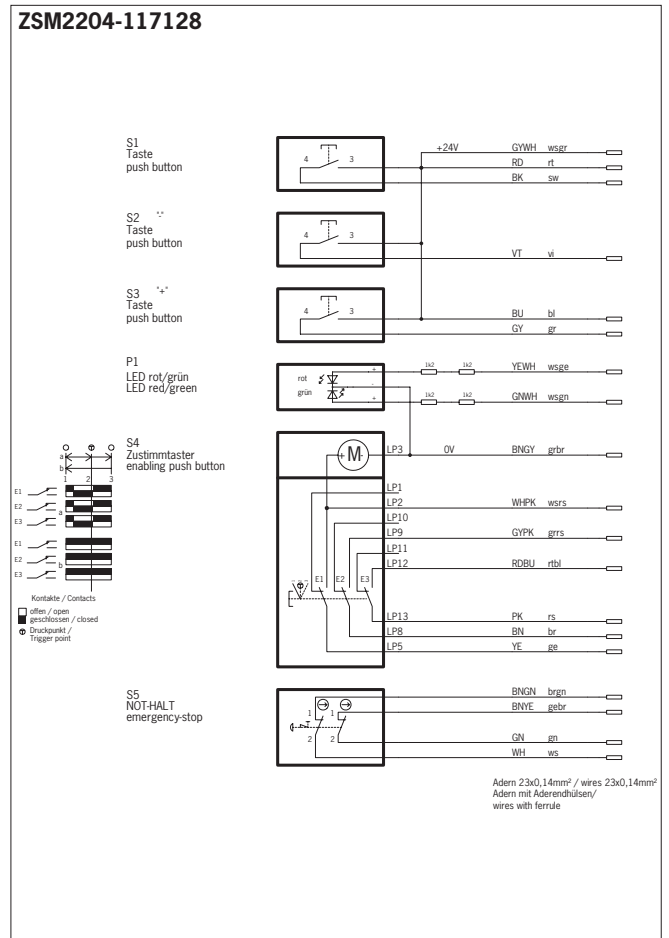
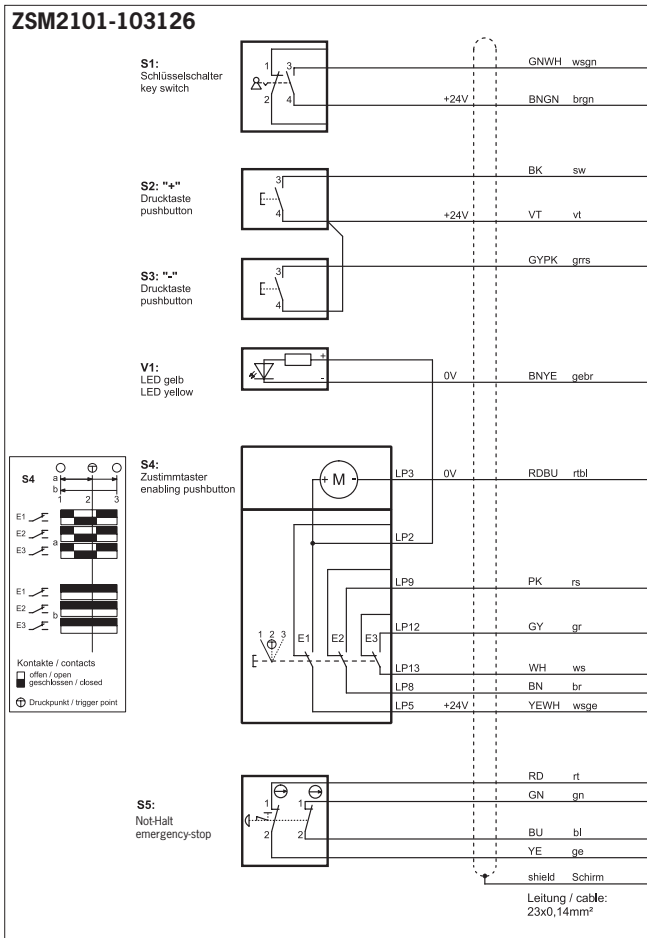

Wiring diagrams

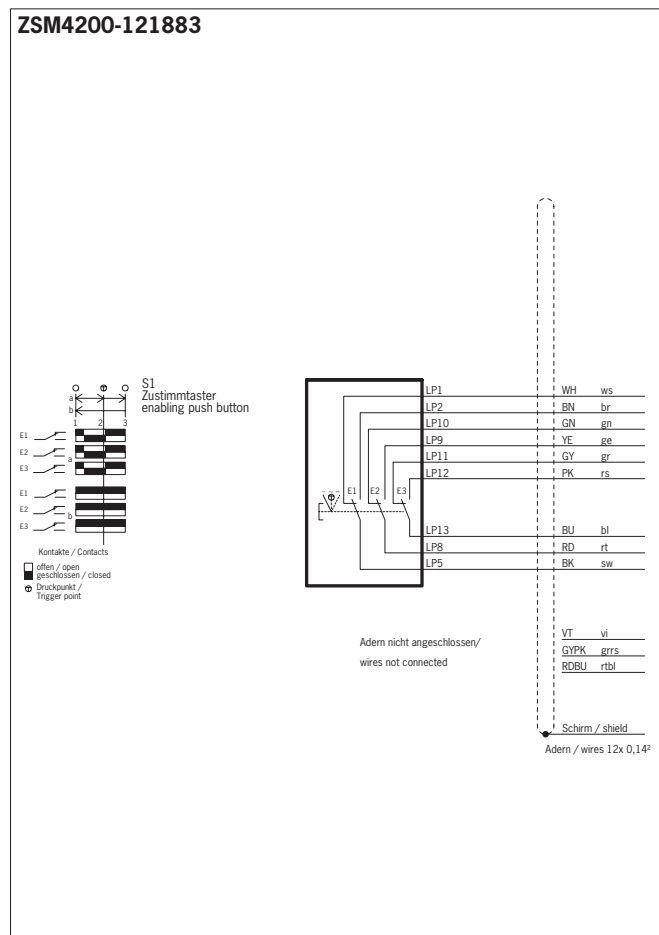
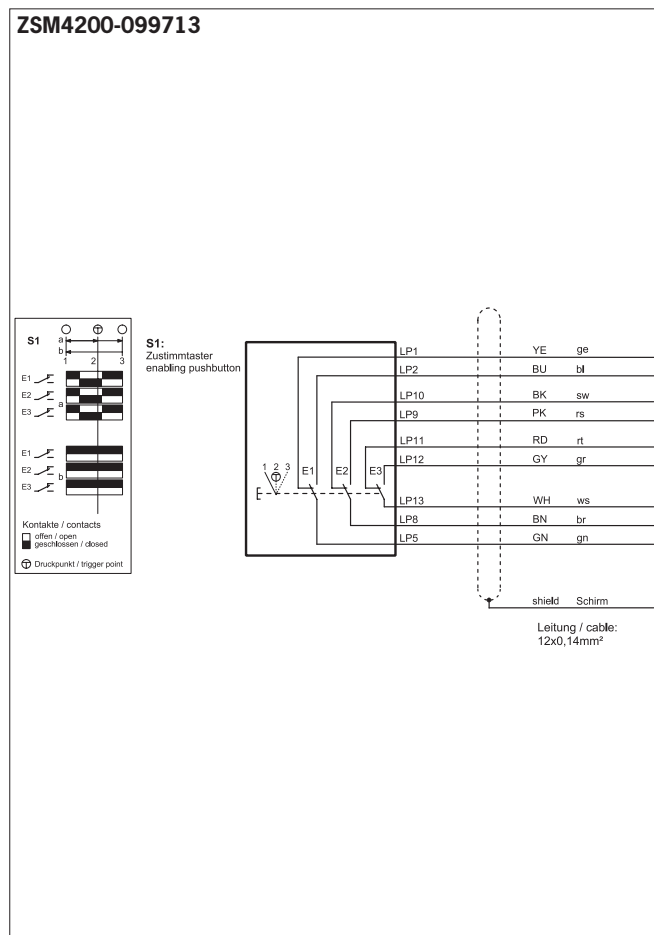
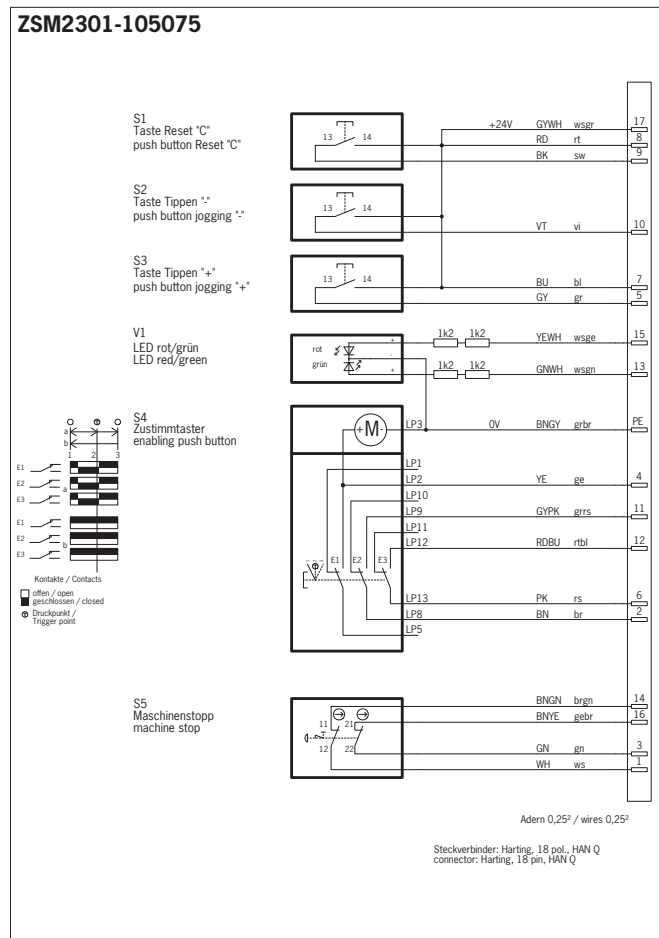
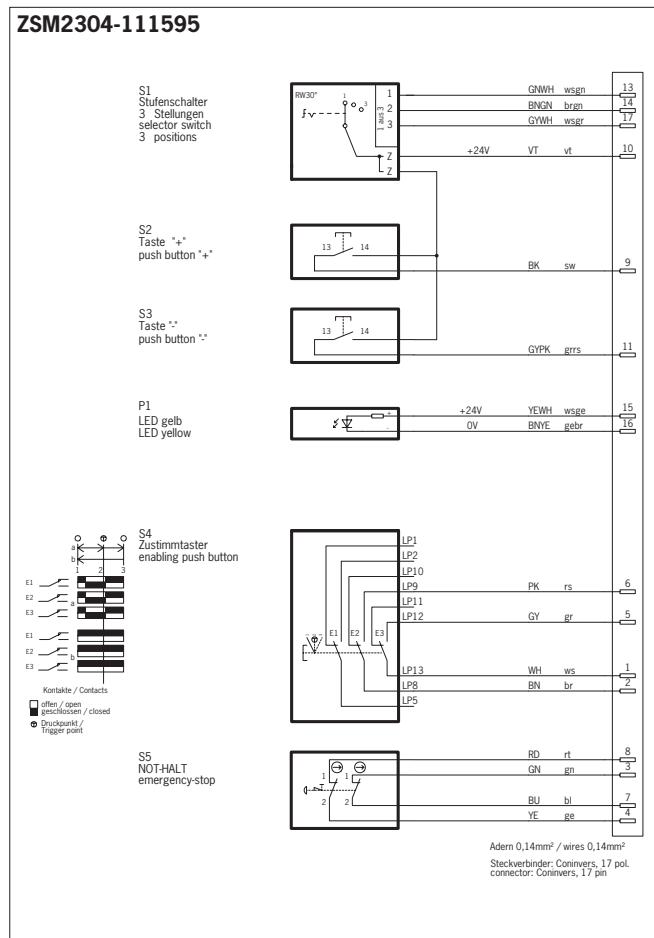

ZSM2300-111871

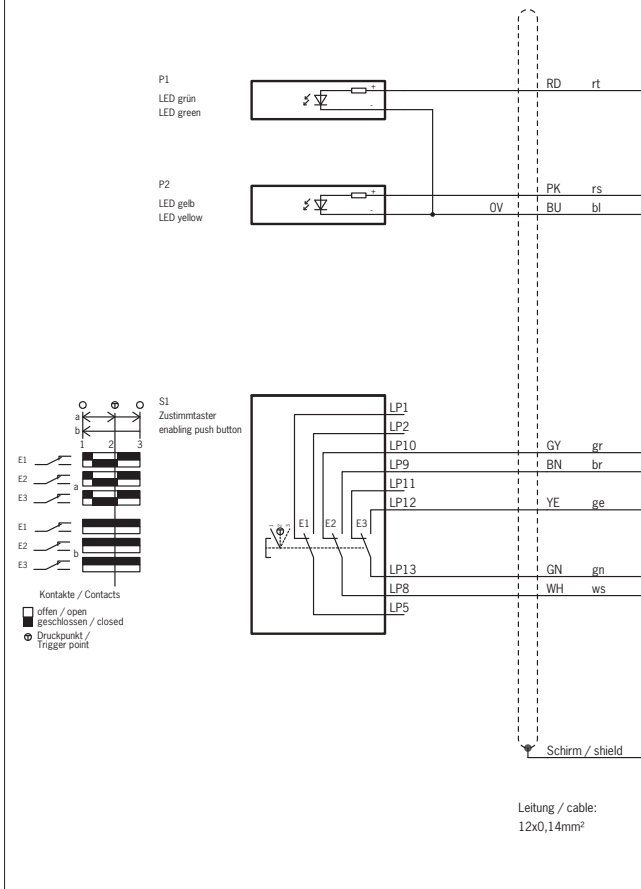

ZSM4200-124156

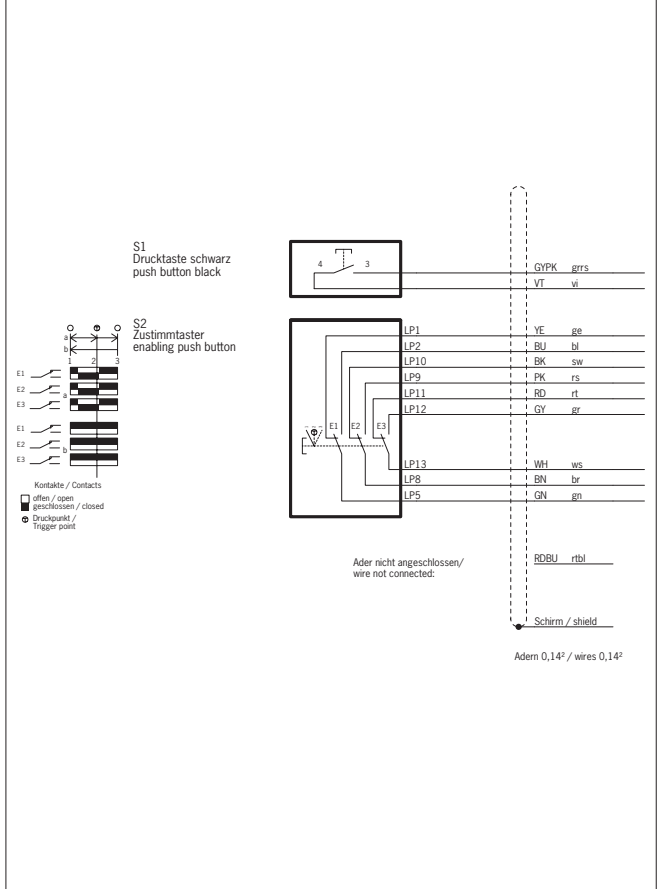

ZSM2100-099714

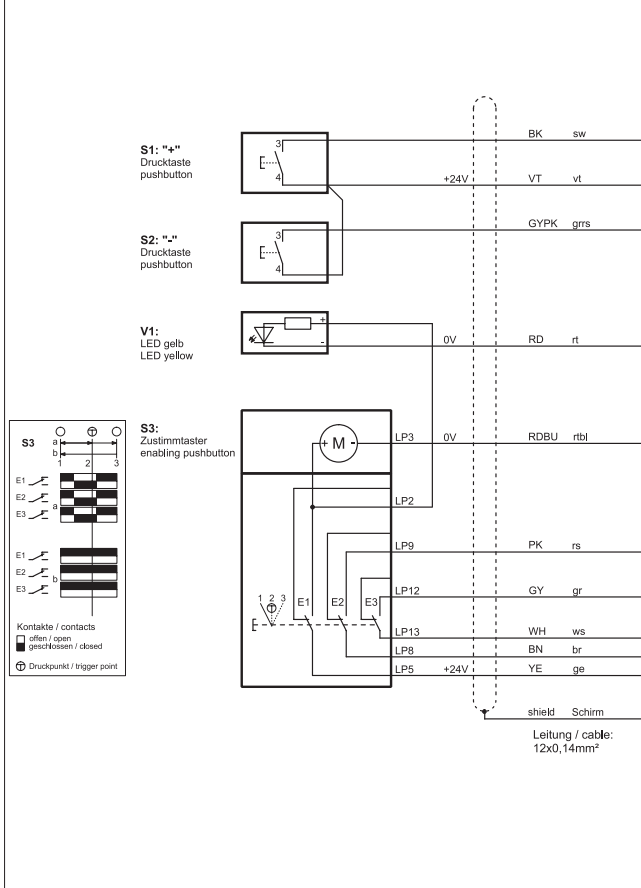

ZSM2300-109971 ZSM2300-112803

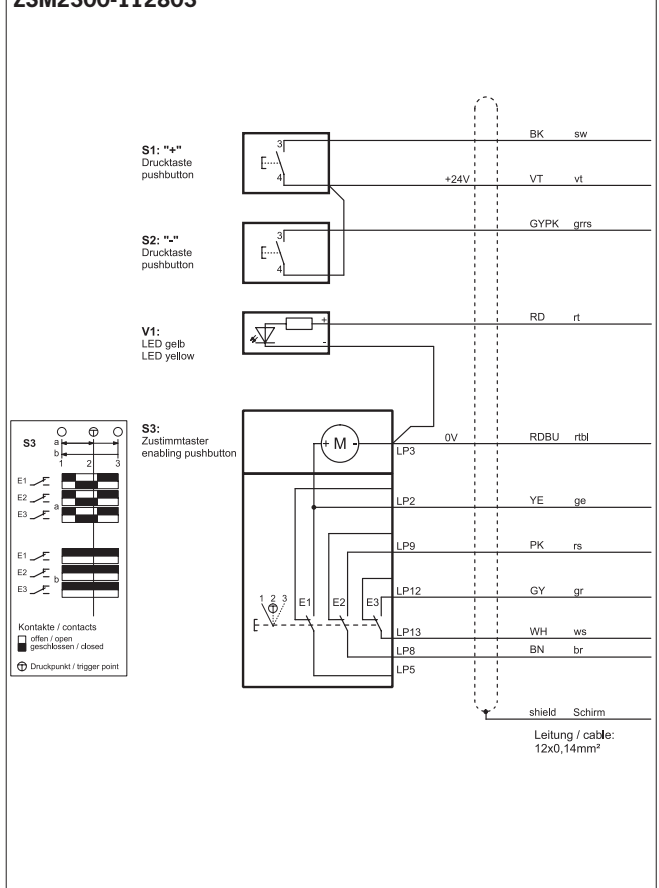

Wiring diagrams

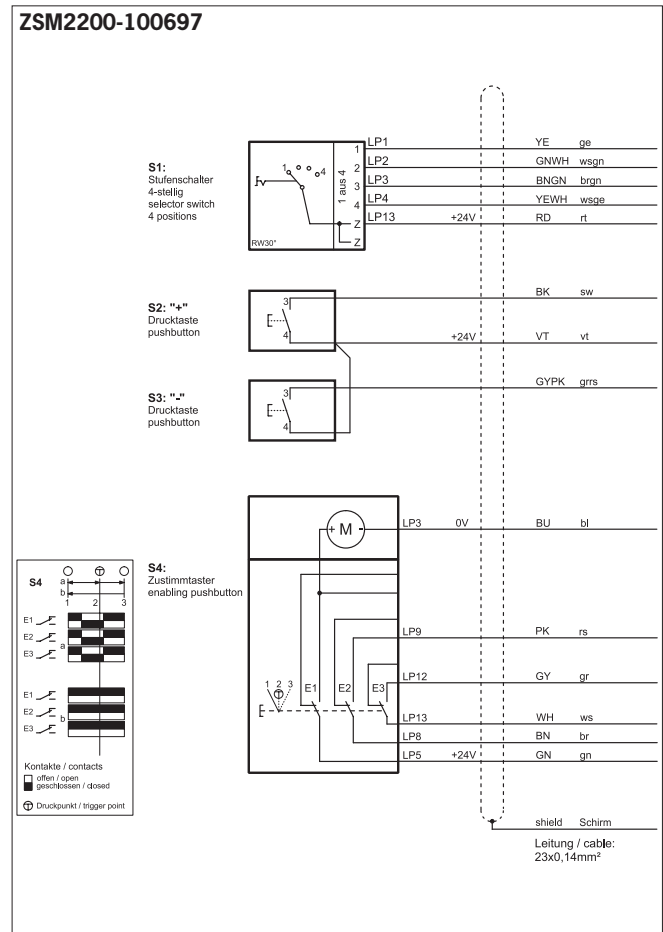
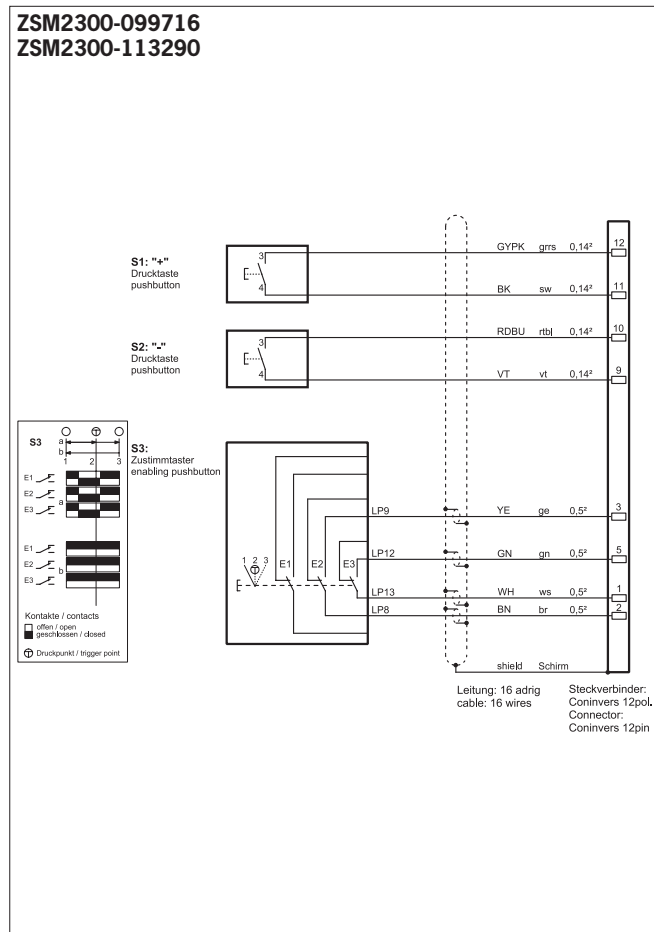
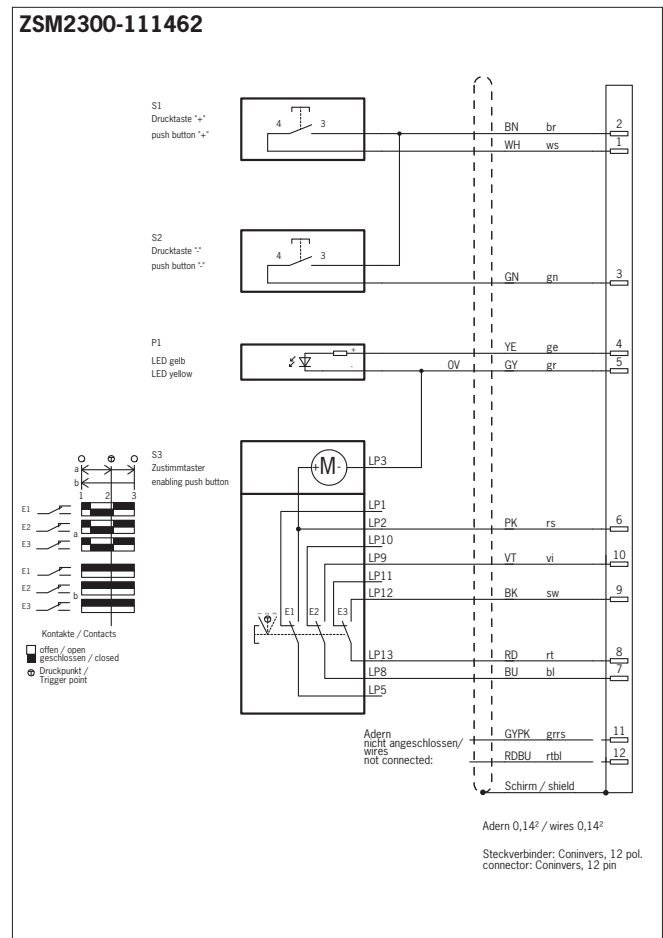
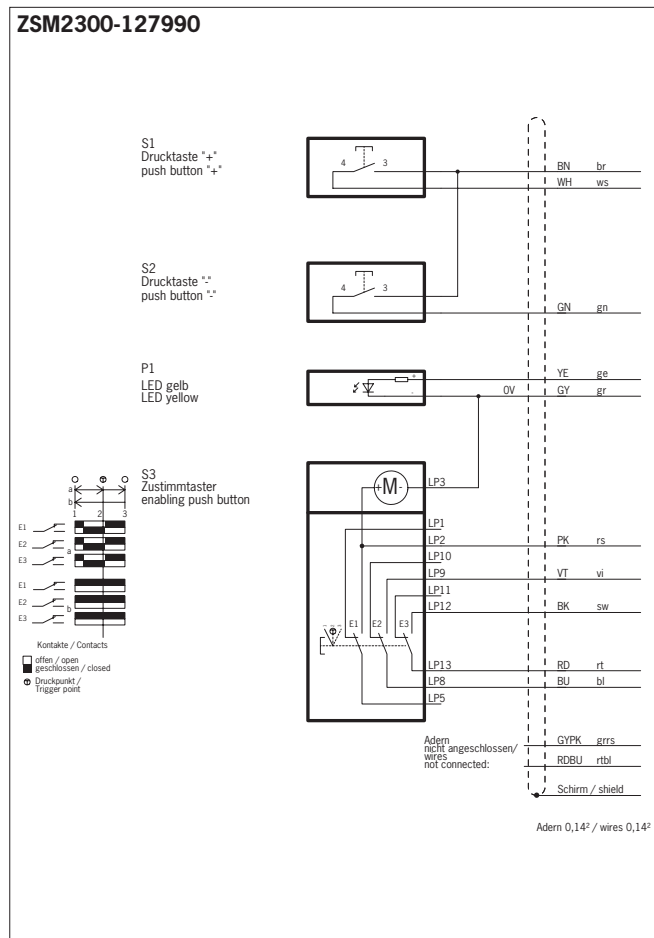

ZSM2100-106103

S1	DCBA
1	0000
2	0001
3	0011
4	0010
5	0110

S1 Stufenschalter
5 Stellungen
selector switch
5 positions

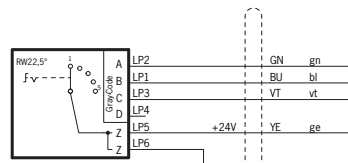

S2 Drucktaste +
push button +

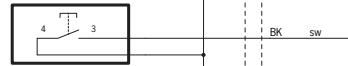

S3 Drucktaste -
push button -

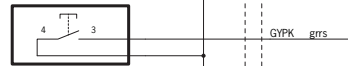

V1 LED gelb
LED yellow



S4 Zustimmungstaster
enabling push button

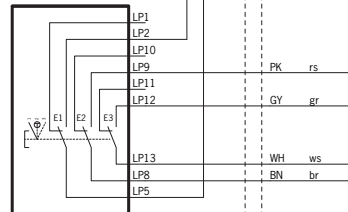

Kontakte / Contacts
offen / open
geschlossen / closed
Druckpunkt / Trigger point

Leitung / cable:
12x0,14mm²

ZSM2200-105308

S1	DCBA
1	0000
2	0001
3	0011
4	0010
5	0110
6	0111
7	0101
8	0100
9	1100
10	1101
11	1111
12	1110

S1 Stufenschalter
12 Stellungen
selector switch
12 positions

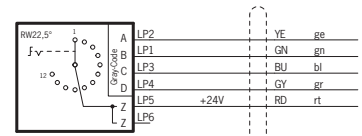

V1 LED gelb
LED yellow

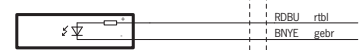

S2 Drucktaste "+"
push button "+"

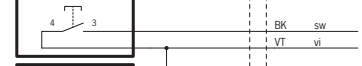

S3 Drucktaste "-"
push button "-"

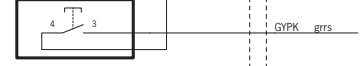

S4 Zustimmungstaster
enabling push button

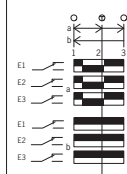
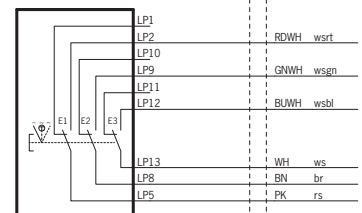

Kontakte / Contacts
offen / open
geschlossen / closed
Druckpunkt / Trigger point

Adern nicht angeschlossen/
wires not connected:

- BNGY gr/br
- BNGN brgn
- GYWH wsgr
- YEWH wspe
- BNBU brbl
- WHPK wsrs
- BNPK rsbr

Leitung / cable:
23x0,14mm²

ZSM3100-103462

S1	DCBA
1	0000
2	0001
3	0011
4	0010
5	0110
6	0111
7	0101
8	0100
9	1100
10	1101
11	1111
12	1110

S1 Stufenschalter
12 Stellungen
selector switch
12 positions

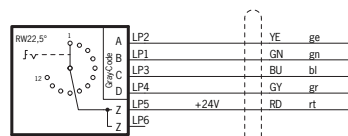

S2 Drucktaste "+"
push button "+"

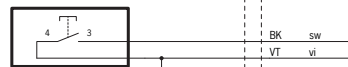

S3 Drucktaste "-"
push button "-"



S4 Zustimmungstaster
enabling push button

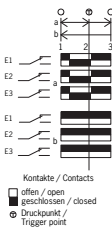
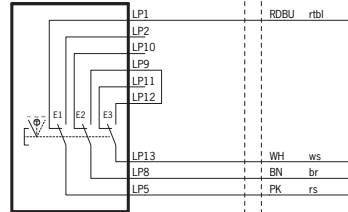

Kontakte / Contacts
offen / open
geschlossen / closed
Druckpunkt / Trigger point

Leitung / cable:
12x0,14mm²

ZSM2200-122279

S1	DCBA
1	0000
2	0001
3	0011
4	0010
5	0110
6	0111
7	0101
8	0100
9	1100
10	1101
11	1111
12	1110
13	1010
14	1011
15	1001
16	1000

S1 Stufenschalter
16 Stellungen
selector switch
16 positions

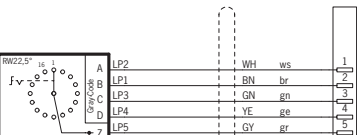

S2 "+"
Drucktaste
push button



S3 "-"
Drucktaste
push button



S4 Zustimmungstaster
enabling push button

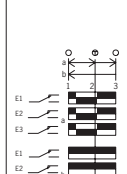
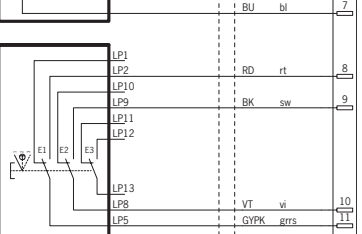

Kontakte / Contacts
offen / open
geschlossen / closed
Druckpunkt / Trigger point

Adern und Pin nicht angeschlossen/
wire and pin not connected

- RDBU rtbl

Adern / wires 12x 0,14²
Steckerbinder / connector:
Coniners 12pol.

Wiring diagrams

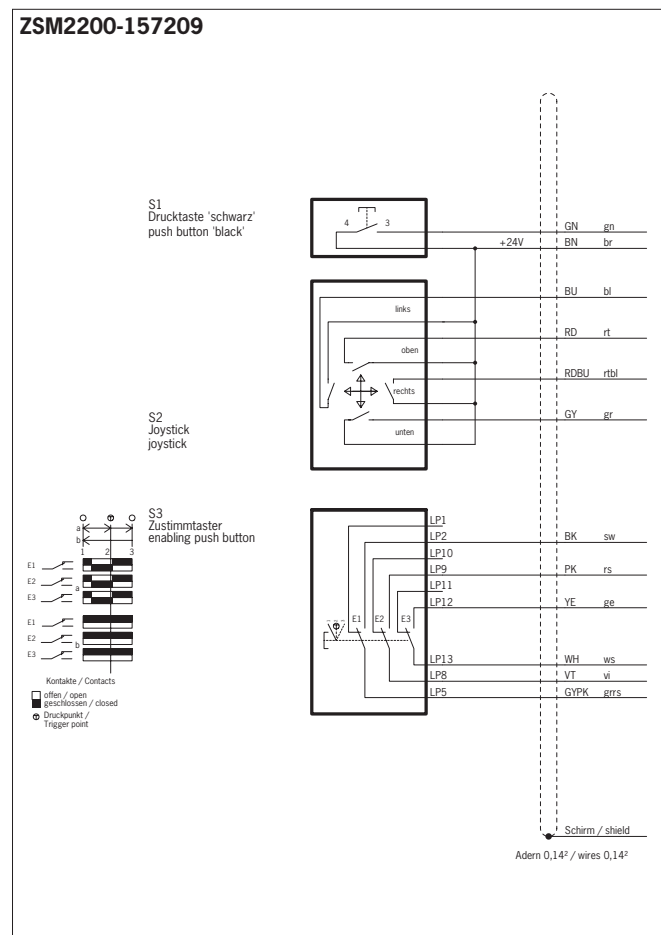
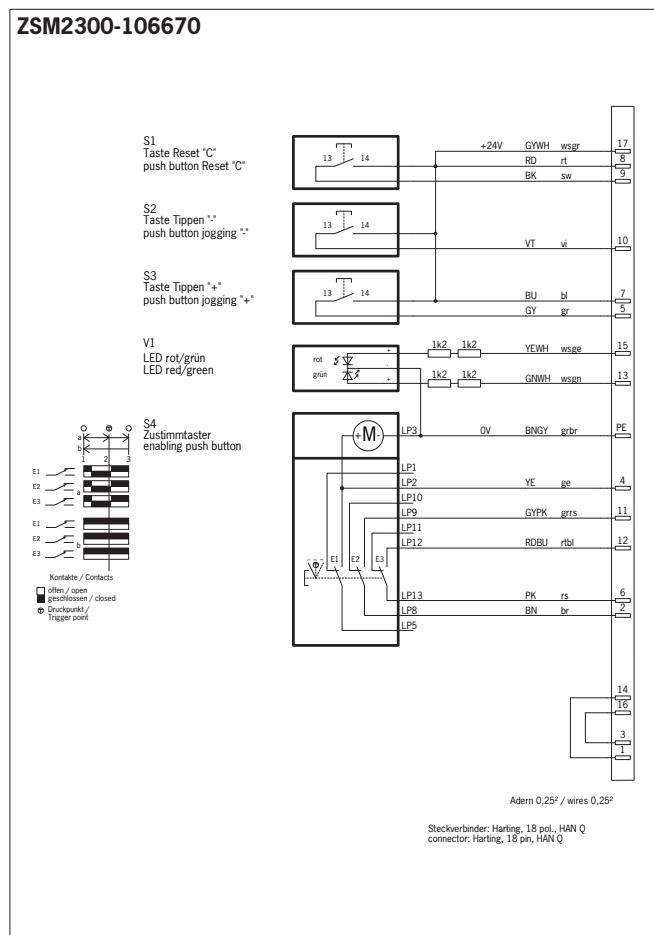
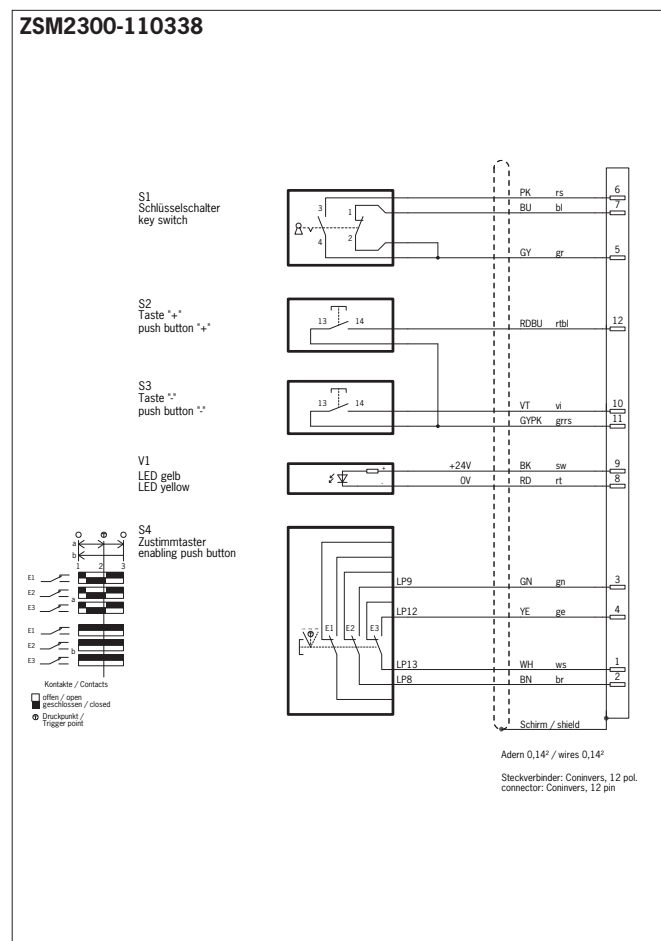
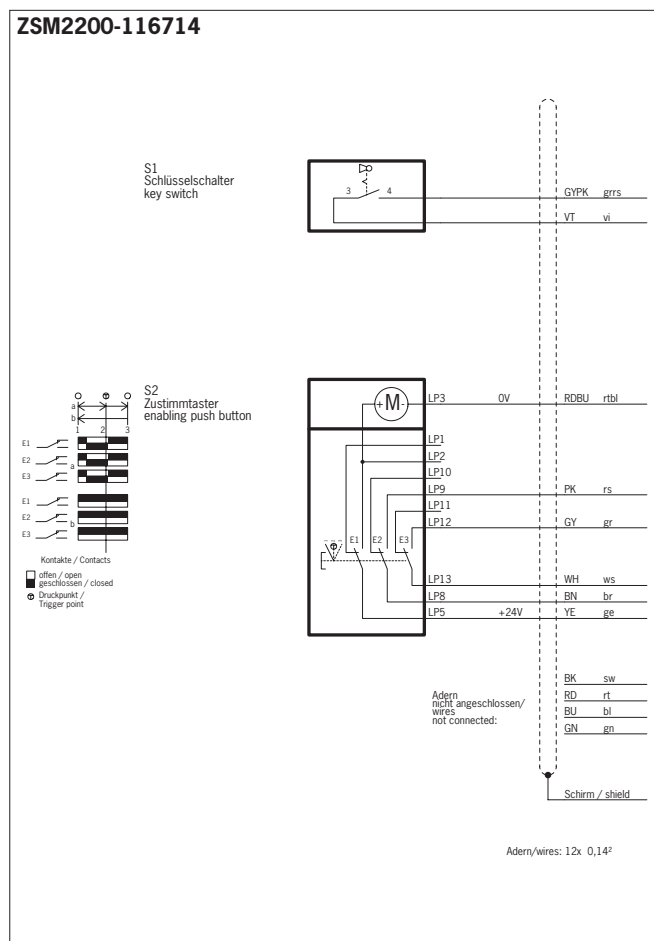

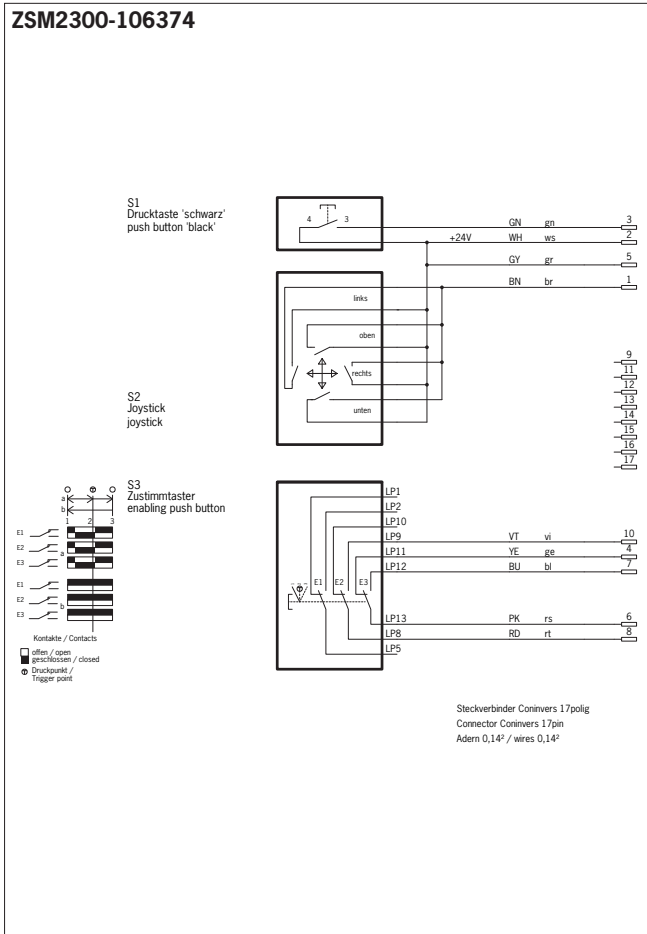

Technical data

Basic enabling switch ZSM

Parameter		Value	Unit
Material	Housing	PA	
	Enabling switch	CR	
	Recessed grip/seal	TPE	
Degree of protection		IP54	
Ambient temperature		-5 ... +60	°C
Weight (incl. connecting cable)		Approx. 1.1	kg

Switching element, enabling switch

Parameter		Value	Unit
Switching contacts		3 changeover contacts	
Mechanical life		1 x 10 ⁶ operating cycles	
Utilization category acc. to IEC 60947-5-1 (for enabling switch)		DC13 U _e 24V I _e 1 A	
Reliability values acc. to EN ISO 13849-1			
B _{10D}		1 x 10 ⁵ operating cycles	

Machine stop

Parameter		Value	Unit
Color of actuating head		Gray	
Color of bottom part		Yellow	
Reset		Pull-to-reset and turn-to-reset button	
Degree of protection		IP65	
Max. number of switching elements		2	
Contact element		2 x positively driven contact	
Utilization category acc. to IEC 60947-5-1		DC-13 U _e 24 V I _e 3 A	

Emergency stop device

Parameter		Value	Unit
Standard		EN ISO 13850/EN 60947-5-5	
Color of actuating head		Red	
Color of bottom part		Yellow	
Reset		Pull-to-reset and turn-to-reset button	
Degree of protection		IP65	
Number of switching elements		2	
Contact element		2 x positively driven contact	
Utilization category acc. to IEC 60947-5-1		DC-13 U _e 24 V I _e 3 A	
Reliability values acc. to EN ISO 13849-1			
B _{10D}		0.1 x 10 ⁶ operating cycles	

Selector switch

Parameter		Value	Unit
Output code		See wiring diagrams	
Switching voltage, max.		25	V AC/DC
Breaking capacity, max.		0.2	VA

Key-operated rotary switch

Parameter		Value	Unit
Switching voltage, max.		30	V AC/DC
Switching current, max.		0.25	A

Reset button/pushbutton

Parameter		Value	Unit
Switching voltage, max.		30	V DC
Switching current, max.		0.1	A

Single-color LED indicator

Parameter	Value	Unit
Housing	Chrome-plated	
Operating voltage	24	V
Color	Yellow or red	

Two-color LED indicator

Parameter	Value	Unit
Forward current typ.	0.02	A
Voltage red	1.85	V
Voltage green	2.2	V

Mini joystick

Parameter	Value	Unit
Utilization category acc. to IEC 60947-5-1	DC-13 I_e 24 V I_e 0.3 A	

Connection using flying lead

Parameter	Value	Unit
Connection	Cable 12 x 0.14 mm ² Cable 23 x 0.14 mm ²	
Short circuit prot. acc. to IEC 60269-1 (control circuit fuse)	2	A gG
Utilization category acc. to EN 60947-5-1		
Enabling switch	DC-13 I_e 1 A U_e 24 V	
Pushbuttons and LEDs	DC-13 I_e 0.3 A U_e 24 V	

Plug connector RC12 connection

Parameter	Value	Unit
Connection	Male connector	
Version	RC12 (11-pin + PE)	
Conductor cross-section	0.14	mm ²
Rated insulation voltage U_i	0.8	kV
Utilization category acc. to EN 60947-5-1		
Enabling switch	DC-13 I_e 1 A U_e 24 V	
Pushbuttons and LEDs	DC-13 I_e 0.3 A U_e 24 V	

Plug connector RC17 connection

Parameter	Value	Unit
Connection	Male connector	
Version	RC17 (17-pin)	
Conductor cross-section	0.14	mm ²
Rated insulation voltage U_i	0.8	kV
Utilization category acc. to EN 60947-5-1		
Enabling switch	DC-13 I_e 1 A U_e 24 V	
Pushbuttons and LEDs	DC-13 I_e 0.3 A U_e 24 V	

Plug connector connection HAN Q17

Parameter	Value	Unit
Connection	Male connector	
Version	HAN Q17 (17-pin)	
Conductor cross-section	0.14	mm ²
Rated insulation voltage U_i	0.8	kV
Utilization category acc. to EN 60947-5-1		
Enabling switch	DC-13 I_e 1 A U_e 24 V	
Pushbuttons and LEDs	DC-13 I_e 0.3 A U_e 24 V	

Technical Data for Enabling Switch ZSE / ZXE / ZSA / ZSB / ZSR **EUCHNER**

Built-in version

Parameter	Value		Unit
Housing material	Polyamide, black		
Protective cap material	CR (neoprene), black		
Degree of protection	on the front	IP65	
Ambient temperature	- 5 to + 60		°C
Installation orientation	Any		
Weight	ZSE / ZSG: approx. 0.1	ZXE: approx. 0.03	kg
Reliability values acc. to EN ISO 13849-1			
B _{10D}	ZSE	5 x 10 ⁵ operating cycles	
	ZXE	0.75 x 10 ⁶ operating cycles	

Hand-held version G1

Parameter	Value		Unit
Housing material	Polyamide, black		
Protective cap material	CR (neoprene), black		
Degree of protection	IP67 / IP65 with additional function (pushbutton, LED)		
Ambient temperature	- 5 to + 50		°C
Weight	Approx. 0.4 (without cable)		kg
Reliability values acc. to EN ISO 13849-1			
B _{10D}	ZSA	5 x 10 ⁵ operating cycles	
	ZSB	5 x 10 ⁵ operating cycles	

Hand-held version G2

Parameter	Value		Unit
Housing material	Polyamide, yellow		
Protective cap material	CR (neoprene), black		
Degree of protection	IP65		
Ambient temperature	- 5 to + 50		°C
Weight	Approx. 1.1 (with 5 m straight cable)		kg
Reliability values acc. to EN ISO 13849-1			
B _{10D}	ZSR	5 x 10 ⁵ operating cycles	

Hand-held version G3

Parameter	Value		Unit
Housing material	Polyamide, yellow		
Protective cap material	CR (neoprene), black		
Degree of protection	IP65		
Ambient temperature	- 5 to + 50		°C
Weight	Approx. 1.5 (with 5 m straight cable)		kg
Reliability values acc. to EN ISO 13849-1			
B _{10D}	ZSB	5 x 10 ⁵ operating cycles	

Switching elements

Parameter	Value			Unit
Switching principle	Slow-action switching contact			
Mechanical life	1 x 10 ⁵ cycles			
Function sequence	2-stage	3-stage		
Switching element with 1 switching contact	10 1 NO	1110 1 NO/NC ⊕		
Switching element with 2 switching contacts	20 2 NO	1210 1 NO/NC ⊕ + 1 NO	2202 2 NO/NC	2220 2 NO/NC ⊕
Switching element with 3 switching contacts	21 2 NO + 1 NC	111 1 NO+1 NC ⊕+1 NC	210 2 NO + 1 NC ⊕	300 3 NO
Switching element with 4 switching contacts	-	121 1 NO + 2 NC ⊕ + 1 NC	220 2 NO + 2 NC ⊕	
Min. switching current at 24 V	1 mA (ZXE switching element 2202: 5 mA)			

Tab connector connection, hand-held kit ZSA

Parameter		Value	Unit
Connection		Tab connector	
Version acc. to IEC 60760		2.8 x 0.8 mm	
Degree of protection	Connections	IP00	
Rated impulse withstand voltage U_{imp}		2.5	kV
Rated insulation voltage U_i		250	V AC/DC
Conventional thermal current I_n		3	A
Short circuit prot. acc. to IEC 60269-1 (control circuit fuse)		4	A gG
Utilization category acc. to EN 60947-5-1	AC-15	I_e 4 A U_e 230 V	
	DC-13	I_e 3 A U_e 24 V	

Screw terminal connection ZXE

Parameter		Value	Unit
Connection		Screw terminals	
Version		4-pin	
Tightening torque, max.		0.15	Nm
Conductor diameter	Single cond.	0.3 - 1.4 mm, AWG 22 - 16	
Conductor nominal diameter	Single cond.	1.5	mm ²
	Flex. cond.	1 mm ² , AWG 16	
Conductor insulation stripping		5	mm
Degree of protection	Connections	IP00	
Rated impulse withstand voltage U_{imp}		1.5	kV
Rated insulation voltage U_i		30	V AC/DC
Conventional thermal current I_n		0.1	A
External fuse U (+LA)/U (+LB)		0.1	A gG
Utilization category acc. to EN 60947-5-1	DC-13	I_e 0.1 A U_e 24 V	

Connection via flying lead

Parameter		Value				Unit
Connection		Cable 3 x 0.75 mm ²	Cable 6 x 0.34 mm ²	Cable 8 x 0.34 mm ²	Cable 8 x 0.5 mm ² + 8 x 0.14 mm ²	
Version	Individual shielding	2 x 0.75	3 x 0.34	4 x 0.34	4 x 0.5	mm ²
	Without shield	1 x 0.75	3 x 0.34	4 x 0.34	4 x 0.5	mm ²
	Additional elements	-	-	-	8 x 0.14	mm ²
Rated impulse withstand voltage U_{imp}		2.5	2.5	2.5	2.5	kV
Rated insulation voltage U_i		250	250	250	250	V AC/DC
Short circuit prot. acc. to IEC 60269-1 (control circuit fuse)		4	2	2	2	A gG
Utilization category for enabling switch acc. to EN 60947-5-1	AC-15	I_e 4 A U_e 230 V	I_e 2 A U_e 230 V	I_e 2 A U_e 230 V	I_e 2 A U_e 230 V	
	DC-13	I_e 3 A U_e 24 V	I_e 2 A U_e 24 V	I_e 2 A U_e 24 V	I_e 2 A U_e 24 V	
Utilization category for pushbuttons and LEDs acc. to EN 60947-5-1	AC-15	-	-	I_e 400 mA U_e 32 V	I_e 400 mA U_e 32 V	
	DC-13	-	-	I_e 100 mA U_e 50 V	I_e 100 mA U_e 50 V	

Plug connector SVM5 connection

Parameter		Value	Unit
Connection		Male connector	
Version		SVM5 (5-pin)	
Connecting cable conductor cross-section		8 x 0.34	mm ²
Degree of protection		IP67 ¹⁾	
Rated impulse withstand voltage U_{imp}		0.8	kV
Short circuit prot. acc. to IEC 60269-1 (control circuit fuse)		2	A gG
Utilization category acc. to EN 60947-5-1	AC-15	I_e 2 A U_e 230 V	
	DC-13	I_e 2 A U_e 24 V	

Plug connector HAN10 connection

Parameter		Value	Unit
Connection		Male connector	
Version		HAN10 (10-pin + PE)	
Connecting cable conductor cross-section		8 x 0.34	mm ²
Degree of protection		IP65 ¹⁾	
Rated impulse withstand voltage U_{imp}		0.8	kV
Short circuit prot. acc. to IEC 60269-1 (control circuit fuse)		2	A gG
Utilization category acc. to EN 60947-5-1	AC-15	I_e 4 A U_e 24 V	
	DC-13	I_e 4 A U_e 24 V	

¹⁾ Only screwed tight with the related plug connector from page 69

Plug connector RC12 connection

Parameter	Value		Unit
Connection	Male connector		
Version	RC12 (11-pin + PE)		
Connecting cable conductor cross-section	8 x 0.5 + 8 x 0.14	6 x 0.34	mm ²
Degree of protection	IP67 / IP65 with additional elements ¹⁾		
Rated impulse withstand voltage U _{imp}	0.8		kV
Short circuit prot. acc. to IEC 60269-1 (control circuit fuse)	2		A gG
Utilization category for enabling switch acc. to EN 60947-5-1	AC-15 DC-13	I _e 2 A U _e 24 V I _e 2 A U _e 24 V	
Utilization category for pushbuttons and LEDs acc. to EN 60947-5-1	AC-15 DC-13	24 V 400 mA 24 V 100 mA	- -

Plug connector RC17 connection

Parameter	Value		Unit
Connection	Male connector		
Version	RC17 (17-pin)		
Connecting cable conductor cross-section	8 x 0.34	8 x 0.5 + 8 x 0.14	mm ²
Degree of protection	IP67 or IP65 with additional elements ¹⁾		
Rated impulse withstand voltage U _{imp}	0.8		kV
Short circuit prot. acc. to IEC 60269-1 (control circuit fuse)	2		A gG
Utilization category for enabling switch acc. to EN 60947-5-1	AC-15 DC-13	I _e 2 A U _e 24 V I _e 2 A U _e 24 V	
Utilization category for pushbuttons and LEDs acc. to EN 60947-5-1	AC-15 DC-13	24 V 400 mA 24 V 100 mA	

Plug connector RC17 Y-coded connection

Parameter	Value		Unit
Connection	Male connector		
Version	RC17 Y-coded (17-pin)		
Connecting cable conductor cross-section	8 x 0.5 + 8 x 0.14		mm ²
Degree of protection	IP67 or IP65 with additional elements ¹⁾		
Rated impulse withstand voltage U _{imp}	0.8		kV
Short circuit prot. acc. to IEC 60269-1 (control circuit fuse)	2		A gG
Utilization category for enabling switch acc. to EN 60947-5-1	AC-15 DC-13	I _e 2 A U _e 24 V I _e 2 A U _e 24 V	
Utilization category for pushbuttons and LEDs acc. to EN 60947-5-1	AC-15 DC-13	24 V 400 mA 24 V 100 mA	

Key-operated rotary switch for housing G3

Parameter	Value	Unit
Housing material	PA black	
Ambient temperature	-25 to + 70	°C
Front degree of protection (installed)	IP65	°C
Switching principle	Slow-action contact elements	
Switching element	1 x NC contact + 1 x NO contact	A
Max. switching current	250	mA
Switching voltage	30	V
Contact resistance	≤ 200	mΩ
Connection	Tinned circuit board connection	mΩ

Selector switch for housing G3

Parameter	Value	Unit
Front degree of protection (installed)	IP65	
Center point fixing	M7 x 0.75	
Detent position	Max. 12, end stop can be adjusted as required from 2 to 12 detent positions	°C
Output code	Binary-coded	
Max. switching current	0.5	A
Max. switching voltage	AC 115 V, DC 24 V on installation in G3 or HB.. housing	
Max. breaking capacity	10	VA
Contact resistance	≤ 6	mΩ
Connection	Soldered connection	mΩ

¹⁾ Only screwed tight with the related plug connector from page 66ff

Illuminated pushbutton for housing G3

Parameter	Value	Unit
Housing material	PA6 black	
Cover material	PC, transparent	
Ambient temperature	-25 to +70	°C
Front degree of protection (installed)	IP65	
Switching principle	Snap-action contact elements	
Switching element	NC + NO	
Max. switching current	4	A
Switching voltage	250 V, 12 ... 24 V on installation in G3 or HB.. housing	V
Contact resistance	≤ 200	mΩ
Connection	Soldered connection	
Lighting	Incandescent lamp, white, 21 mA 24 V	

Emergency stop button for housing G3

Parameter	Value	Unit
Color of actuating head	Red	
Color of bottom part	Yellow	
Ambient temperature	-25 to +60	°C
Max. number of switching elements	2	
Degree of protection	IP65	

Index by item designation

Item	Order no.	Page	Item	Order no.	Page
Connecting cable for enabling switch ZXE-111276	115123	68	ZSA2A1S05A	055404	34
Actuator Z-G-C1932	084833	65	ZSA2A2G02A	099371	34
Blanking plug, 12-pin	073293	66	ZSA2A2G05A	055406	34
Blanking plug, 17-pin	096159	66	ZSA2A2G10A	055407	34
Blanking plug, complete, 12-pin	073291	66	ZSA2A2G15A	057007	34
Female plug, 17-pin	106349	67	ZSA2A2S05A	055408	34
Rotary knob	097141	58	ZSA2A3G10A	070785	34
Pushbutton, blue	086757	56	ZSA2A4G05A	070764	34
Pushbutton, yellow	086756	56	ZSA2A4G10A	070765	34
Pushbutton, green	086754	56	ZSA2A4G20A	073300	34
Pushbutton, red	086753	56	ZSA2A4L25AC1689	086788	34
Pushbutton, black	083640	56	ZSA2A4S05A	070766	34
Pushbutton, white	086755	56	ZSA2B2G05A	055410	35
Pushbutton, white ⊖	137984	56	ZSA2B2G10A	055411	35
Pushbutton, white ⊕	137981	56	ZSA2B2G15CC1926	072870	36
Replacement key	092386	56	ZSA2B4G05A	072961	35
ES-XA1E-BV3UU02R	106435	55	ZSA2B4G10CC1830	077489	37
Flange connector, 12-pin	073290	66	ZSA2B4G10CC1861	098064	37
Flange connector, 17-pin	077502	66	ZSA2B4G10CC2322	110560	36
Male flange connector, 17-pin	106360	67	ZSA2B4S05A	085118	35
Holder, complete	052406	65	ZSB072403	072403	45
Holder ZSM	102969	64	ZSB072645	072645	45
Holder ZSM with magnet	102965	64	ZSB077029	077029	43
LED indicator GE 106347	106347	55	ZSB077040	077040	40
Cable, 12-core, straight, 10,000 mm	087381	59	ZSB083317	083317	39
Cable, 12-core, straight, 3,500 mm	087379	59	ZSB085058	085058	43
Cable, 12-core, straight, 5,000 mm	087380	59	ZSB085126	085126	39
Cable, 12-core, coiled, 3,900 mm	086721	59	ZSB087821	087821	44
Cable, 12-core, coiled, 5,400 mm	086722	59	ZSB090489	090489	46
Cable, 23-core, straight, 10,000 mm	087384	59	ZSB092378	092378	39
Cable, 23-core, straight, 3,500 mm	087382	59	ZSB096900	096900	39
Cable, 23-core, straight, 5,000 mm	087383	59	ZSB100570	100570	43
Cable, 23-core, coiled, 3,900 mm	087408	59	ZSB103161	103161	39
Cable, 23-core, coiled, 5,400 mm	087409	59	ZSB122338	122338	47
Cable holder	047820	65	ZSB2A2G05A	073260	39
Magnetic holder	059340	65	ZSB2A2G05C	073264	40
Machine stop	116005	55	ZSB2A2G10A	073261	39
Key-operated rotary switch	083639	56	ZSB2A2G10C	073265	40
Coiled cable with plug connector, 9 m	106392	68	ZSB2A2G15A	095612	39
Plug connector, 12-pin	073294	66	ZSB2A4G06A-C2302	110031	39
Plug connector, 17-pin	096481	66	ZSB2B4G03-C2176	099807	41
Selector switch, 12 detent positions, Gray code	097033	58	ZSB2B4G05C-C2044	092996	40
Selector switch, 16 detent positions, Gray code	097034	58	ZSB2B4G10C-C2281	106277	41
Selector switch, 2 detent positions, 1 of 2	097026	57	ZSB2B4S22A	109136	39
Selector switch, 3 detent positions, 1 of 3	097027	57	ZSE2-1	052448	10
Selector switch, 4 detent positions, 1 of 4	097028	57	ZSE2-2	052449	10
Selector switch, 5 detent positions, Gray code	097029	58	ZSE2-2C1692	070752	10
Selector switch, 6 detent positions, Gray code	097030	58	ZSE2-3	070782	10
Selector switch, 7 detent positions, Gray code	097031	58	ZSE2-4	070762	10
Selector switch, 8 detent positions, Gray code	097032	58	ZSE2-4C1801	091098	11
ZSA086707C1983	086707	38	ZSE2-4C1943	083477	10
ZSA092141C2038	092141	37	ZSG1-2	070793	50
ZSA1-1	070750	61	ZSM2100-099714	099714	14, 23
ZSA1-2	070800	61	ZSM2100-106103	106103	15, 26
ZSA1-3	070736	61	ZSM2101-103126	103126	14, 18
ZSA1A2L25AC1909	082557	51	ZSM2104-123678	123678	14, 19
ZSA1A2S05A	094321	51	ZSM2200-100697	100697	15, 26
ZSA1A5S05AC2325	110755	51	ZSM2200-105308	105308	15, 27
ZSA2-1	070734	60	ZSM2200-116714	116714	15, 29
ZSA2-2	070735	60	ZSM2200-122279	122279	15, 28
ZSA2-4	070792	60	ZSM2200-157209	157209	15, 31
ZSA2A1G05A	055402	34	ZSM2201-126706	126706	14, 17
ZSA2A1G10A	055403	34	ZSM2204-117128	117128	14, 18

Index by order number

Order no.	Item	Page
047820	Cable holder	65
052406	Holder, complete	65
052448	ZSE2-1	10
052449	ZSE2-2	10
055402	ZSA2A1G05A	34
055403	ZSA2A1G10A	34
055404	ZSA2A1S05A	34
055406	ZSA2A2G05A	34
055407	ZSA2A2G10A	34
055408	ZSA2A2S05A	34
055410	ZSA2B2G05A	35
055411	ZSA2B2G10A	35
055428	ZSR2A2G10A	42
055429	ZSR2A2S05A	42
057007	ZSA2A2G15A	34
059340	Magnetic holder	65
070734	ZSA2-1	60
070735	ZSA2-2	60
070736	ZSA1-3	61
070750	ZSA1-1	61
070752	ZSE2-2C1692	10
070762	ZSE2-4	10
070764	ZSA2A4G05A	34
070765	ZSA2A4G10A	34
070766	ZSA2A4S05A	34
070782	ZSE2-3	10
070785	ZSA2A3G10A	34
070792	ZSA2-4	60
070793	ZSG1-2	50
070800	ZSA1-2	61
072403	ZSB072403	45
072645	ZSB072645	45
072870	ZSA2B2G15CC1926	36
072961	ZSA2B4G05A	35
073260	ZSB2A2G05A	39
073261	ZSB2A2G10A	39
073264	ZSB2A2G05C	40
073265	ZSB2A2G10C	40
073290	Flange connector, 12-pin	66
073291	Blanking plug, complete, 12-pin	66
073293	Blanking plug, 12-pin	66
073294	Plug connector, 12-pin	66
073300	ZSA2A4G20A	34
077029	ZSB077029	43
077040	ZSB077040	40
077489	ZSA2B4G10CC1830	37
077502	Flange connector, 17-pin	66
082557	ZSA1A2L25AC1909	51
083317	ZSB083317	39
083477	ZSE2-4C1943	10
083639	Key-operated rotary switch	56
083640	Pushbutton, black	56
084833	Actuator Z-G-C1932	65
085058	ZSB085058	43
085118	ZSA2B4S05A	35
085126	ZSB085126	39
086707	ZSA086707C1983	38
086721	Cable, 12-core, coiled, 3,900 mm	59
086722	Cable, 12-core, coiled, 5,400 mm	59
086753	Pushbutton, red	56
086754	Pushbutton, green	56
086755	Pushbutton, white	56
086756	Pushbutton, yellow	56

Order no.	Item	Page
086757	Pushbutton, blue	56
086788	ZSA2A4L25AC1689	34
087379	Cable, 12-core, straight, 3,500 mm	59
087380	Cable, 12-core, straight, 5,000 mm	59
087381	Cable, 12-core, straight, 10,000 mm	59
087382	Cable, 23-core, straight, 3,500 mm	59
087383	Cable, 23-core, straight, 5,000 mm	59
087384	Cable, 23-core, straight, 10,000 mm	59
087408	Cable, 23-core, coiled, 3,900 mm	59
087409	Cable, 23-core, coiled, 5,400 mm	59
087821	ZSB087821	44
090489	ZSB090489	46
091098	ZSE2-4C1801	11
091336	ZXE-091336	12
092141	ZSA092141C2038	37
092378	ZSB092378	39
092386	Replacement key	56
092996	ZSB2B4G05C-C2044	40
094321	ZSA1A2S05A	51
095612	ZSB2A2G15A	39
096159	Blanking plug, 17-pin	66
096481	Plug connector, 17-pin	66
096900	ZSB096900	39
097026	Selector switch, 2 detent positions, 1 of 2	57
097027	Selector switch, 3 detent positions, 1 of 3	57
097028	Selector switch, 4 detent positions, 1 of 4	57
097029	Selector switch, 5 detent positions, Gray code	58
097030	Selector switch, 6 detent positions, Gray code	58
097031	Selector switch, 7 detent positions, Gray code	58
097032	Selector switch, 8 detent positions, Gray code	58
097033	Selector switch, 12 detent positions, Gray code	58
097034	Selector switch, 16 detent positions, Gray code	58
097141	Rotary knob	58
097609	ZSR2A4G05A	42
098064	ZSA2B4G10CC1861	37
099371	ZSA2A2G02A	34
099713	ZSM4200-099713	14, 21
099714	ZSM2100-099714	14, 23
099716	ZSM2300-099716	14, 25
099807	ZSB2B4G03-C2176	41
100570	ZSB100570	43
100697	ZSM2200-100697	15, 26
102965	Holder ZSM with magnet	64
102966	ZSM4204-102966	14, 16
102969	Holder ZSM	64
103126	ZSM2101-103126	14, 18
103161	ZSB103161	39
103462	ZSM3100-103462	15, 27
104085	ZSR2A4S05A	42
104833	ZXE-104833	12
105075	ZSM2301-105075	14, 20
105308	ZSM2200-105308	15, 27
105645	ZSM4204-105645	14, 16
106103	ZSM2100-106103	15, 26
106104	ZSM4200-106104	54
106105	ZSM4200-106105	54
106277	ZSB2B4G10C-C2281	41
106347	LED indicator GE 106347	55
106349	Female plug, 17-pin	67
106360	Male flange connector, 17-pin	67
106374	ZSM2300-106374	15, 31
106392	Coiled cable with plug connector, 9 m	68
106435	ES-XA1E-BV3UU02R	55

Representatives

International

Austria

EUCHNER GmbH
Aumühlweg 17-19/Halle 1C
2544 Leobersdorf
Tel. +43 720 010 200
Fax +43 720 010 200-20
info@euchner.at

Benelux

EUCHNER (BENELUX) BV
Visschersbuurt 23
3356 AE Papendrecht
Tel. +31 78 615-4766
Fax +31 78 615-4311
info@euchner.nl

Brazil

EUCHNER Com.Comp.
Eletronicos Ltda.
Av. Prof. Luiz Ignácio Anhaia Mello,
no. 4387
Vila Graciosa
São Paulo - SP - Brasil
CEP 03295-000
Tel. +55 11 29182200
Fax +55 11 23010613
euchner@euchner.com.br

Canada

EUCHNER Canada Inc.
2105 Fasan Drive
Oldcastle, ON NOR 1L0
Tel. +1 519 800-8397
Fax +1 519 737-0314
sales@euchner.ca

China

EUCHNER (Shanghai)
Trading Co., Ltd.
No. 15 building,
No. 68 Zhongchuan Road,
Songjiang
Shanghai, 201613, P.R.C
Tel. +86 21 5774-7090
Fax +86 21 5774-7599
info@euchner.com.cn

Czech Republic

EUCHNER electric s.r.o.
Trnkova 3069/117h
628 00 Brno
Tel. +420 533 443-150
Fax +420 533 443-153
info@euchner.cz

France

EUCHNER France S.A.R.L.
Parc d'Affaires des Bellevues
Allée Rosa Luxembourg
Bâtiment le Colorado
95610 ERAGNY sur OISE
Tel. +33 1 3909-9090
Fax +33 1 3909-9099
info@euchner.fr

Hungary

EUCHNER Magyarország Kft.
FSD Park 2.
2045 Törökbálint
Tel. +36 1 919 0855
Fax +36 1 919 0857
info@euchner.hu

India

EUCHNER (India) Pvt. Ltd.
401, Bremen Business Center,
City Survey No. 2562,
University Road
Aundh, Pune - 411007
Tel. +91 20 64016384
Fax +91 20 55885148
info@euchner.in

Italy

TRITECNICA SpA
Viale Lazio 26
20135 Milano
Tel. +39 02 541941
Fax +39 02 55810474
info@tritecnica.it

Japan

EUCHNER Co., Ltd.
1269-1 Komakiharashinden,
Komaki-shi, Aichi-ken
485-0012, Japan
Tel. +81 568 74 5237
Fax +81 568 74 5238
info@euchner.jp

Korea

EUCHNER Korea Co., Ltd.
115 Gasan Digital 2 - Ro
(Gasan-dong, Daeryung
Technotown 3rd Rm 810)
153 - 803 Kumchon-Gu, Seoul
Tel. +82 2 2107-3500
Fax +82 2 2107-3999
info@euchner.co.kr

Mexico

EUCHNER México S de RL de CV
Conjunto Industrial PK Co.
Carretera Estatal 431 km. 1+300
Ejido El Colorado, El Marqués
76246 Querétaro, México
Tel. +52 442 402 1485
Fax +52 442 402 1486
info@euchner.mx

Poland

EUCHNER Sp. z o.o.
Krańskięskiego 29
40-019 Katowice
Tel. +48 32 252 20 15
Fax +48 32 252 20 13
info@euchner.pl

Spain

EUCHNER, S.L.
Gurutze 12 - Local 1
Poligono Belartza
20018 San Sebastian
Tel. +34 943 316-760
Fax +34 943 316-405
info@euchner.es

Switzerland

EUCHNER AG
Falknisstrasse 9a
7320 Sargans
Tel. +41 81 720-4590
Fax +41 81 720-4599
info@euchner.ch

Turkey

EUCHNER Endüstriyel Emniyet
Teknolojileri Ltd. Şti.
Hattat Bahattin Sok.
Ceylan Apt. No. 13/A
Göztepe Mah.
34730 Kadıköy / İstanbul
Tel. +90 216 359-5656
Fax +90 216 359-5660
info@euchner.com.tr

United Kingdom

EUCHNER (UK) Ltd.
Unit 2 Petre Drive,
Sheffield
South Yorkshire
S4 7PZ
Tel. +44 114 2560123
Fax +44 114 2425333
sales@euchner.co.uk

USA

EUCHNER USA Inc.
6723 Lyons Street
East Syracuse, NY 13057
Tel. +1 315 701-0315
Fax +1 315 701-0319
info@euchner-usa.com

EUCHNER USA Inc.
Detroit Office
130 Hampton Circle
Rochester Hills, MI 48307
Tel. +1 248 537-1092
Fax +1 248 537-1095
info@euchner-usa.com

Germany

Augsburg

EUCHNER GmbH + Co. KG
Ingenieur- und Vertriebsbüro
Julius-Spokojny-Weg 8
86153 Augsburg
Tel. +49 821 56786540
Fax +49 821 56786541
peter.klopper@euchner.de

Berlin

EUCHNER GmbH + Co. KG
Ingenieur- und Vertriebsbüro
Ulmenstraße 115a
12621 Berlin
Tel. +49 30 50508214
Fax +49 30 56582139
alexander.walz@euchner.de

Chemnitz

EUCHNER GmbH + Co. KG
Ingenieur- und Vertriebsbüro
Am Vogelherd 2
09627 Bobritzsch-Hilbersdorf
Tel. +49 37325 906000
Fax +49 37325 906004
jens.zehrtner@euchner.de

Düsseldorf

EUCHNER GmbH + Co. KG
Ingenieur- und Vertriebsbüro
Tippgarten 3
59427 Unna
Tel. +49 2308 9337284
Fax +49 2308 9337285
christian.schimke@euchner.de

Essen

Thomas Kreißl
fördern - steuern - regeln
Hackenbergweg 8a
45133 Essen
Tel. +49 201 84266-0
Fax +49 201 84266-66
info@kreisslessen.de

Freiburg

EUCHNER GmbH + Co. KG
Ingenieur- und Vertriebsbüro
Steige 5
79206 Breisach
Tel. +49 7664 403833
Fax +49 7664 403834
peter.seifert@euchner.de

Lübeck

EUCHNER GmbH + Co. KG
Ingenieur- und Vertriebsbüro
Am Stadtrand 13
23556 Lübeck
Tel. +49 451 88048371
Fax +49 451 88184364
martin.pape@euchner.de

Nürnberg

EUCHNER GmbH + Co. KG
Ingenieur- und Vertriebsbüro
Steiner Straße 22a
90522 Oberasbach
Tel. +49 911 6693829
Fax +49 911 6696722
raff.paulus@euchner.de

Stuttgart

EUCHNER GmbH + Co. KG
Ingenieur- und Vertriebsbüro
Kohlhammerstraße 16
70771 Leinfelden-Echterdingen
Tel. +49 711 7597-0
Fax +49 711 7597-303
oliver.laier@euchner.de
uwe.kupka@euchner.de

Wiesbaden

EUCHNER GmbH + Co. KG
Ingenieur- und Vertriebsbüro
Adolfsallee 3
65185 Wiesbaden
Tel. +49 611 98817644
Fax +49 611 98895071
giancarlo.pasquesi@euchner.de



EUCHNER

More than safety.



Support hotline

You have technical questions about our products or how they can be used?
For further questions please contact your local sales representative.



Comprehensive download area

You are looking for more information about our products?
You can simply and quickly download operating instructions, CAD or ePLAN data and accompanying software for our products at www.euchner.com.



Customer-specific solutions

You need a specific solution or have a special requirement?
Please contact us. We can manufacture your custom product even in small quantities.



EUCHNER near you

You are looking for a contact at your location? Along with the headquarters in Leinfelden-Echterdingen, the worldwide sales network includes 18 subsidiaries and numerous representatives in Germany and abroad – you will definitely also find us near you.

www.euchner.com

EUCHNER GmbH + Co. KG

Kohlhammerstraße 16
70771 Leinfelden-Echterdingen
Germany
Tel. +49 711 7597-0
Fax +49 711 753316
info@euchner.de
www.euchner.com

EUCHNER

More than safety.